

## 1. SUGGESTION FOR NEW MACHINE

- 1) It takes about 100 operation hours to enhance its designed performance.
- 2) Operate according to below three steps and avoid excessive operation for the initial 100 hours.

Service meter	Load
Until 10 hours	About 60%
Until 100 hours	About 80%
After 100 hours	100%

※ **Excessive operation may deteriorate the potential performance of machine and shorten lifetime of the machine.**

### 3) Be careful during the initial 100 hours operation

- (1) Check daily for the level and leakage of coolant, engine oil, hydraulic oil and fuel.
- (2) Check regularly the lubrication and fill grease daily all lubrication points.
- (3) Tighten bolts.
- (4) Warm up the machine fully before operation.
- (5) Check the gauges occasionally during the operation.
- (6) Check if the machine is operating normally during operation.

### 4) Replace followings after initial 50 hours of operation

Checking items	Service
Engine oil	Replace
Engine oil filter element	
Hydraulic oil return filter element	
Hydraulic oil tank drain filter cartridge	
Line filter element	
Fuel filter	

Avoid excessive operation for initial 100 hours

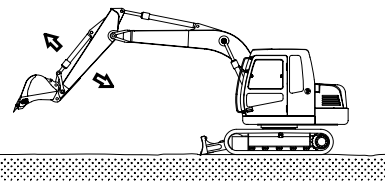

7074OP01

## 2. CHECK BEFORE STARTING THE ENGINE

- 1) Look around the machine and under the machine to check for loosen nut or bolts, collection of dirt, or leakage of oil, fuel or coolant and check the condition of the work equipment and hydraulic system. Check also loosen wiring, and collection of dust at places which reach high temperature.  
※ **Refer to the daily check on the chapter 6, maintenance.**
- 2) Adjust seat to fit the contours of the operator's body for the pleasant operation.
- 3) Adjust the rear view mirror.

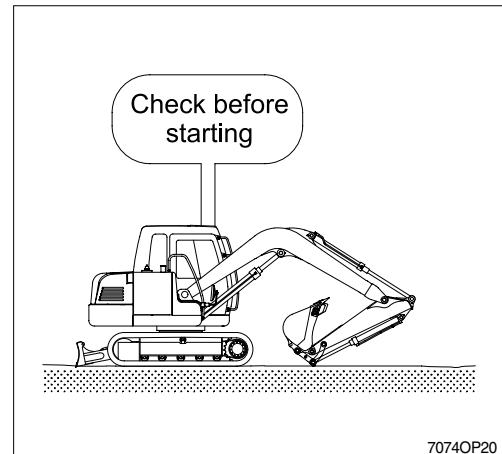

### 3. STARTING AND STOP THE ENGINE

#### 1) CHECK INDICATOR LIGHTS

- (1) Check if all the operating lever is on the neutral position.
- (2) Turn the starting switch to the ON position, and check following.
  - ① If all the lamps light ON and buzzer sounding for 2 seconds.
  - ② After lamp check 「CL : 1.0」, the version of cluster program, is displayed on 「**Monitoring display(3)**」 for 5 seconds and the cluster returns to default.
  - ③ Only below lamps will light ON and all the other lights will turn OFF after 2 seconds.
    - Battery charging warning lamp(2)
    - Engine oil pressure warning lamp(1)

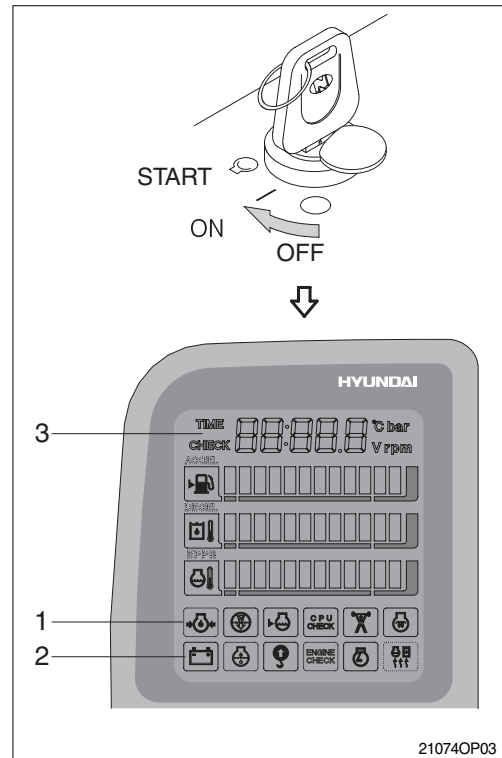

## 2) STARTING ENGINE

- ※ Sound horn to warn surroundings after checking if there are obstacles in the area.
- ※ Replace the engine oil and fuel referring to recommended oils at page 2-12.
- ※ Fill anti-freeze solution to the coolant as required.

- (1) Check if all levers are on the neutral position.
  - (2) Turn the starting switch to ON position.
  - (3) Check if the preheat pilot lamp(1) is turned ON.
    - ※ When the preheat pilot lamp is turned ON, the preheating function is actuated within 20 seconds in accordance with temperature of the coolant.
    - ※ After the preheat pilot lamp is turned OFF, engine start within 10 seconds.
  - (4) Start engine by turning the starting switch to the START position.
  - (5) Release the starting switch immediately after starting engine to avoid possible damage to the starting motor.
- ※ After engine started, the preheat pilot lamp is turned ON to reduce the white smoke at least 30 seconds.

- ※ If the engine does not start, the start switch turn ON position and press the preheat switch for preheating.  
After the preheating, start the engine again.
- ※ If the engine does not start, allow the starter to cool for 10~20 seconds before attempting to start the engine again.  
At the cold, allow 2 minute before attempting to start the engine again.

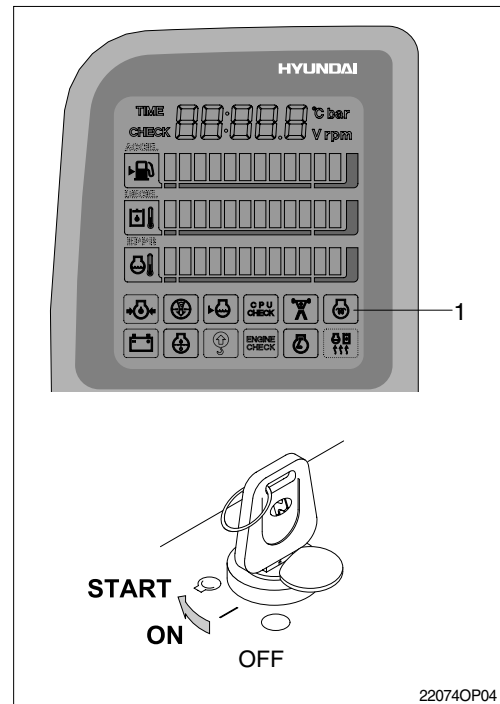

22074OP04

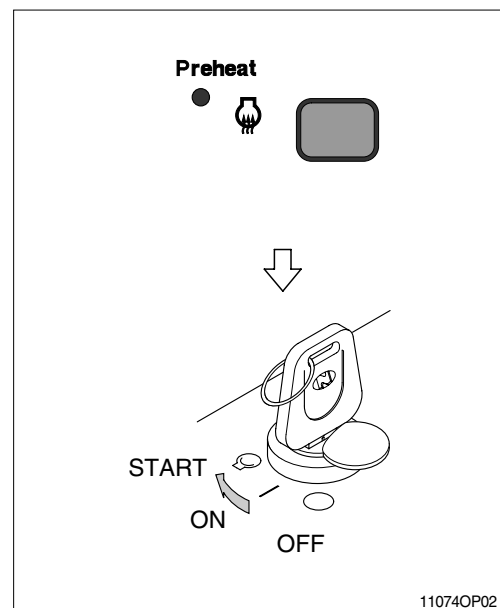

11074OP02

### 3) INSPECTION AFTER ENGINE START

Inspect and confirm the following after engine starts.

- (1) Is the level gauge of hydraulic oil tank in the normal level?
- (2) Are there leakages of oil or water?
- (3) Are all the warning lamps OFF(1-7)?
- (4) Is the indicator of engine coolant temperature gauge(8) and hydraulic oil temperature gauge(9) in the green zone?
- (5) Is the engine sound and the color of exhaust gas normal?
- (6) Are the sound and vibration normal?

- ※ Do not increase engine speed quickly after starting, it can damage engine.
- ※ If there are problems in the control panel, stop the engine immediately and correct problem as required.

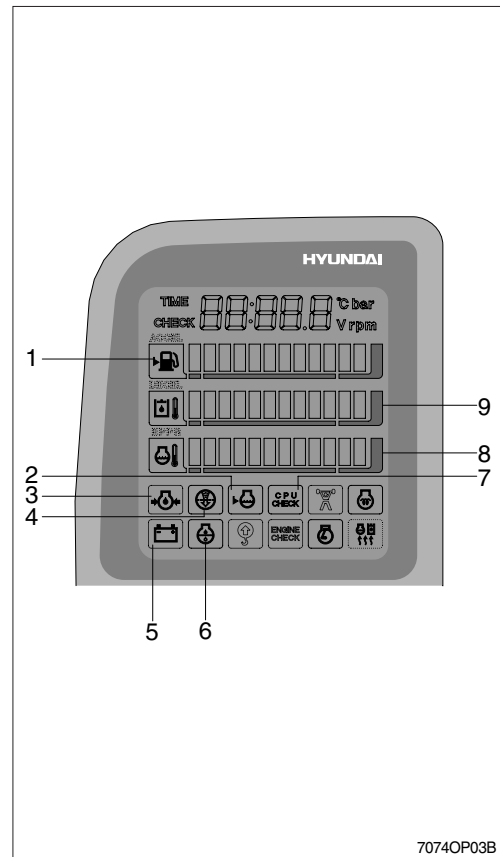

### 4) WARMING-UP OPERATION

- ※ The most suitable temperature for the hydraulic oil is about 50°C (122°F). It can cause serious trouble in the hydraulic system by sudden operation when the hydraulic oil temperature is below 25°C (77°F). Then temperature must be raised to at least 25°C (77°F) before starting work.

- (1) Run the engine at low idling for 5 minutes.
- (2) Speed up the idling and run the engine at mid-range speed.
- (3) Operate bucket lever for 5 minutes.
  - ※ Do not operate anything except bucket lever.
- (4) Run the engine at the high speed and operate the bucket lever and arm lever for 5-10 minutes.
  - ※ Operate only the bucket lever and arm lever.
- (5) This warming-up operation will be completed by operation of all cylinders several times, and operation of swing and traveling.
  - ※ Increase the warming-up operation during winter.

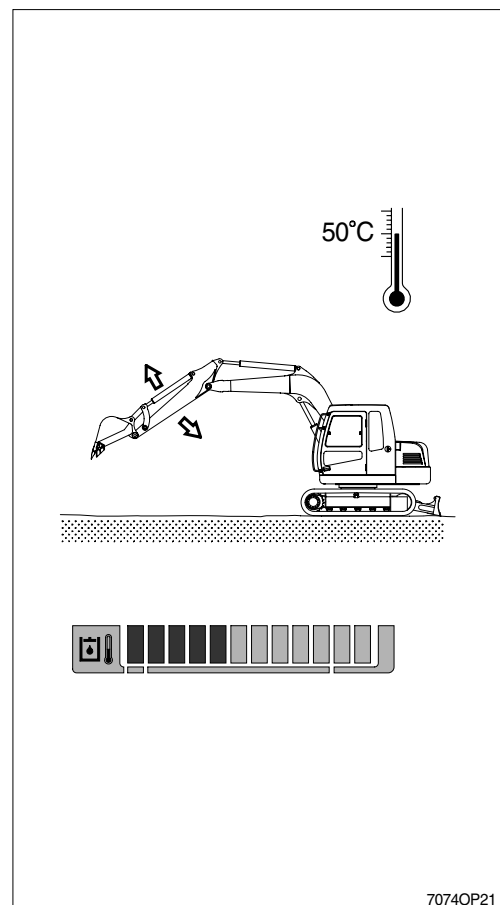

## 5) TO STOP THE ENGINE

- ※ If the engine is abruptly stopped before it has cooled down, engine life may be greatly shortened. Consequently, do not abruptly stop the engine apart from an emergency.
  - ※ In particular if the engine has overheated, do not abruptly stop it but run it at medium speed to allow it to cool gradually, then stop it.
- (1) Down the bucket on the ground then put all the levers in the neutral position.
  - (2) Run the engine at low idling speed for about 5 minutes.
  - (3) Return the key of starting switch to the OFF position.
  - (4) Remove the key to prevent other people using the machine and LOCK safety lever.
  - (5) Lock the cab door.

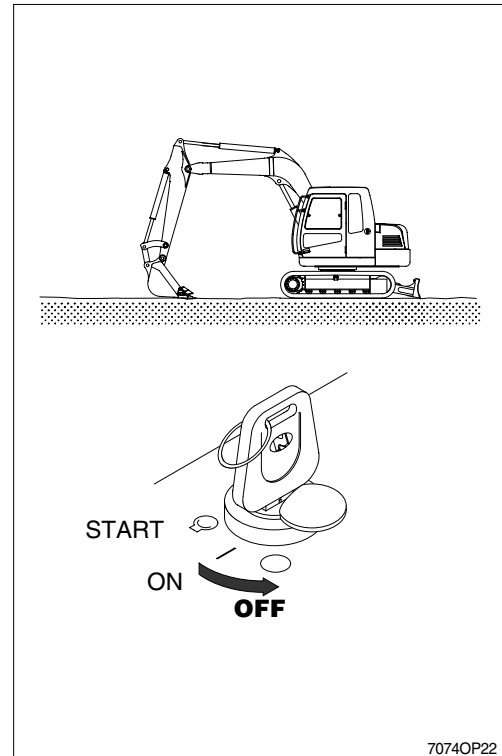

## 4. MODE SELECTION SYSTEM

### 1) STRUCTURE OF CAPO SYSTEM

CAPO, Computer Aided Power Optimization system, is the name of mode selection system developed by Hyundai.

#### (1) Power mode

3 power modes can be selected for the optimal power of the machine operation.

##### ① H mode

This mode is used for heavy-duty work.

##### ② S mode

When key switch is turned ON, this mode is selected automatically. This mode is used for standard work.

##### ③ L mode

This mode is used for light-duty work.

#### (2) Preheat switch

This switch is used for starting the engine in cold weather. If pressed, grid heater is activated to get easier engine starting.

#### (3) Wiper switch

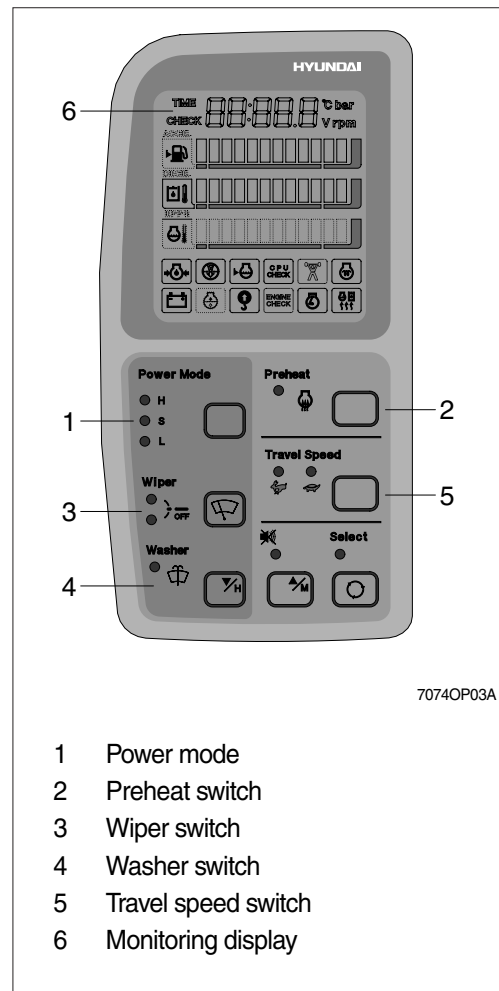

- Press the switch once to operate wiper.
- Press the switch once more to intermittently operate wiper low speed.
- Press the switch a third time to turn off wiper.



**(4) Washer switch**

The washer liquid is sprayed and the wiper is operated only while pressing the switch.

**(5) Travel speed switch**

-  : Low speed traveling.
-  : High speed traveling.

**(6) Monitoring system**

Information of machine performance as monitored by the machine control unit(MCU) can be displayed on the **monitoring display**.

※ Refer to 4-11 page for details.

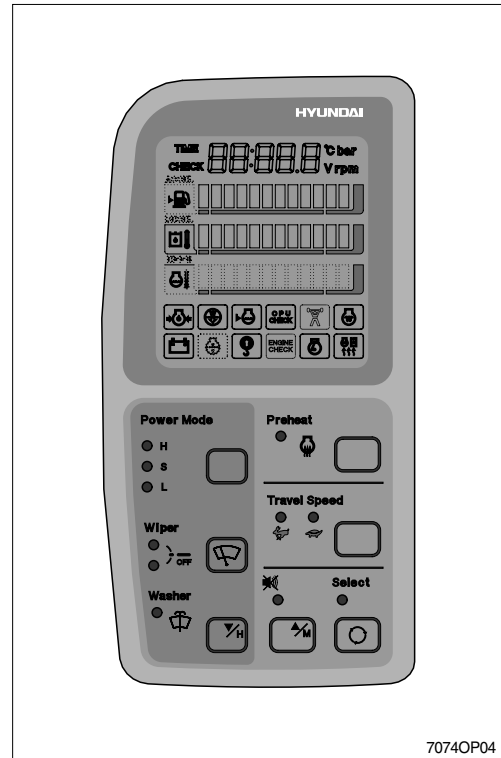

**(7) Self diagnostic system**

The MCU diagnoses problems in the CAPO system caused by electric parts' malfunction and by open or short circuit, which are displayed on the **monitoring display** as error codes.

(Refer to the service manual for error code).

**(8) Anti-restart system**

The system protects the starter from inadvertent restarting after the engine is already operational.



## 2) HOW TO OPERATE MODE SELECTION SYSTEM

### (1) When start key is turned ON

- ① When start key is turned ON, all illumination lamps are ON and all lamps are OFF automatically after 5 seconds. But the battery charging warning lamp and the engine oil pressure warning lamp keep turned ON until engine starting.
- ② After lamp check 「CL : 1.0」, the version of cluster program, is displayed on 「Monitoring display」 for 2 seconds.
- ③ After the version of program is displayed, the cluster returns to default. Exactly engine rpm, battery charging warning lamp and engine oil pressure warning lamp are turned ON and S mode, one touch decel, low travel speed(Turtle mark) are displayed.
- ④ In default condition self-diagnostic function including trouble detecting of electric system can be carried out.

※ Refer to 4-11 page for details.

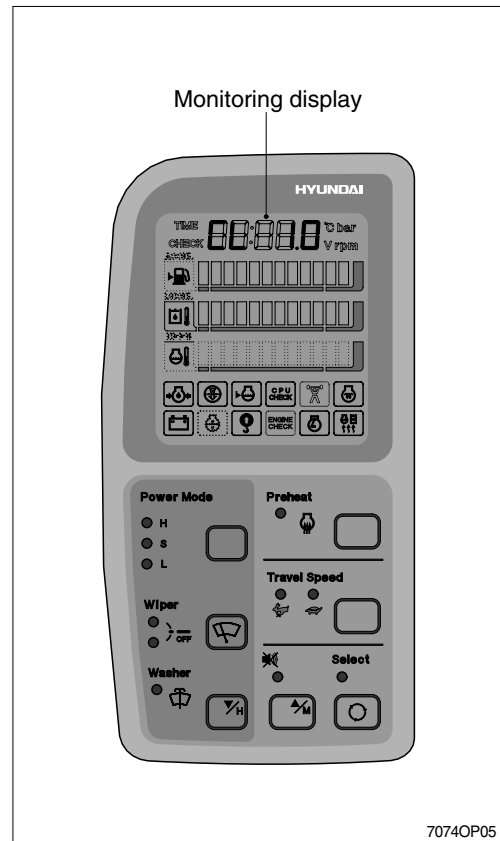

### (2) After engine start

- ① When the engine is started, three lamps are ON as below.

Mode		Status
Power mode	S	ON
Travel speed	Low(🐢)	ON
One touch decel		ON

- In this condition, tachometer indicates low idle,  $950 \pm 100$ rpm.
  - If coolant temperature is below  $30^{\circ}\text{C}$ , after 10 seconds the engine speed increases to  $1200 \pm 100$ rpm automatically to warm up the machine.
  - After 2-3 minutes, you can select any mode depending on job requirement.
- ② Self-diagnostic function can be carried out the same as start key is ON.

※ Refer to 4-11 page for details.



### 3) SELECTION OF POWER MODE

#### (1) S mode

When the accel dial is at setting 10 and one touch decel mode is cancelled and S mode is selected.

Engine rpm	Effect
2050 ± 50	Same power as <b>non</b> mode type machine.

※ When the accel dial is located below 9 the engine speed decreases about 50~100rpm per dial set.

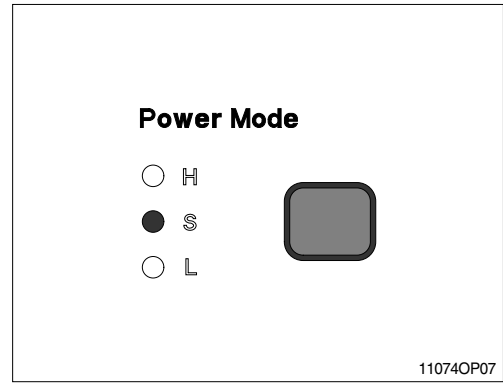

#### (2) H mode

When the accel dial is at setting 10 and one touch decel mode is cancelled and H mode is selected.

Engine rpm	Effect
2200 ± 50	Approximately 110% of power and speed available than <b>non</b> mode type machine or <b>S</b> mode.

※ When the accel dial is located below 9 the engine speed decreases about 50~100rpm per dial set.

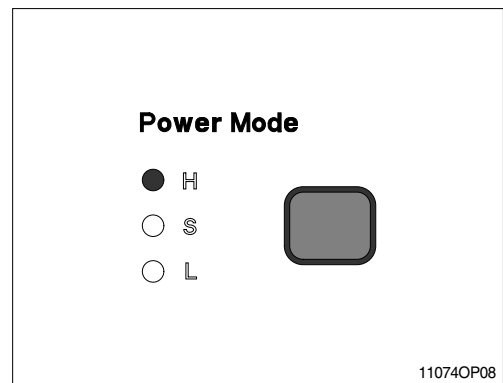

#### (3) L mode

When the accel dial is at setting 10 and one touch decel mode is cancelled and L mode is selected.

Engine rpm	Effect
1900 ± 50	Approximately 85% of power and speed available than <b>non</b> mode type machine or <b>S</b> mode.

※ When the accel dial is located below 9 the engine speed decreases about 50~100rpm per dial set.

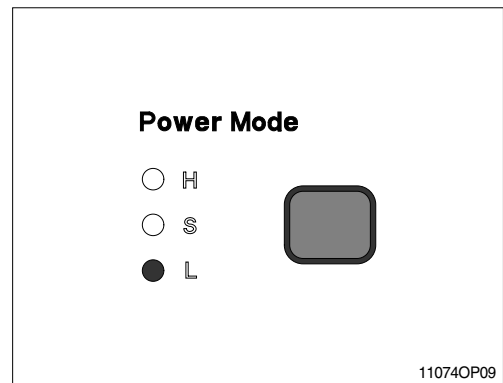

#### 4) MONITORING DISPLAY

Information of machine performance as monitored by the CPU controller can be displayed on the cluster when the operator selects a display mode by touching **SELECT** switch alone or with **BUZZER STOP** switch on the cluster as below.

Display group	How to select display mode		Name	Display on the cluster
	Group selection	Display mode selection		
<b>Group 0</b> (Default)	Way 1 Key switch <b>ON</b> or <b>START</b> Way 2 Touch <b>WASHER</b> switch while pressing <b>BUZZER STOP</b> at group 1~4.	Initial	Engine rpm	950 rpm
		Touch <b>SELECT</b> 1 time	Time	TIME 12:30
		Touch <b>SELECT</b> 2 times	CPU model & version	08:C 1.0
<b>Group 1</b> (Volt, temp, EPPR press, version)	Touch <b>SELECT</b> switch <b>once</b> while pressing <b>BUZZER STOP</b> . In this group <b>SELECT LED ON</b>	Default	Battery voltage(V)	b:24.8v
		Touch <b>SELECT</b> 1 time	Potentiometer voltage(V)	Pa: 2.5v
		Touch <b>SELECT</b> 2 times	Accel dial voltage(V)	dL: 3.8v
		Touch <b>SELECT</b> 3 times	Hydraulic oil temperature(°C)	Hd: 105°C
	Touch <b>SELECT</b> 4 times	Coolant temperature(°C)	Ct: 107°C	
<b>Group 2</b> (Error code)	Touch <b>SELECT</b> switch <b>twice</b> while pressing <b>BUZZER STOP</b> . In this group <b>BUZZER STOP LED</b> blinks	Default	Current error	CHECK Er: 03
		Touch <b>SELECT</b> 1 time	Recorded error (Only key switch ON)	TIME Er: 03
		Press down(▼) & <b>SELECT</b> at the same time	Recorded error deletion (Only key switch ON)	TIME Er: 00
<b>Group 3</b> (Switch input)	Touch <b>SELECT</b> switch <b>3 times</b> while pressing <b>BUZZER STOP</b> . In this group <b>SELECT LED</b> blinks at 0.5sec interval	Default	One touch decel switch	o d: on or off
		Touch <b>SELECT</b> 1 time	Preheat switch	PH: on or off
		Touch <b>SELECT</b> 2 times	Overload pressure switch	o l: on or off
<b>Group 4</b> (Output)	Touch <b>SELECT</b> switch <b>4 times</b> while pressing <b>BUZZER STOP</b> . In this group <b>SELECT LED</b> blinks at 1sec interval	Default	Hourmeter	Ho: on or off
		Touch <b>SELECT</b> 1 time	Neutral relay (Anti-restart relay)	nr: on or off
		Touch <b>SELECT</b> 2 times	Travel speed solenoid	SS: on or off
		Touch <b>SELECT</b> 3 times	Preheat relay	PR: on or off

※ By touching **SELECT** switch once while pressing **BUZZER STOP**, display group shifts.

Example : Group 0 → 1 → 2 → 3 → 4 → 0

## 5. OPERATION OF WORKING DEVICE

※ **Confirm the operation of control lever and working device.**

- 1) Left control lever controls arm and swing.
- 2) Right control lever controls boom and bucket.
- 3) When you release the control lever, control lever returns to neutral position automatically.

※ **When operating swing, consider the swing distance by inertia.**

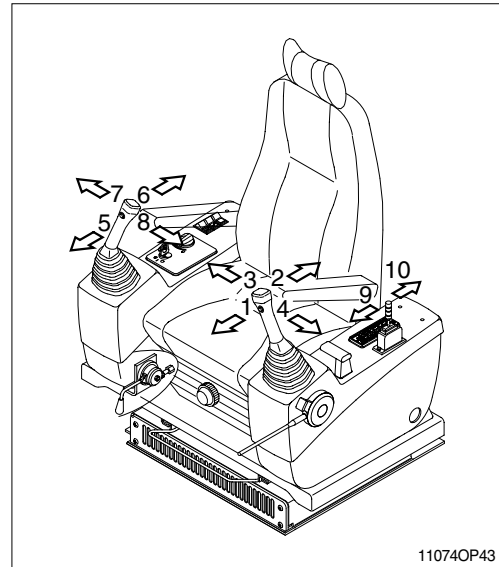

11074OP43

※ **Left control lever**

- 1 Arm roll-out
- 2 Arm roll-in
- 3 Swing right
- 4 Swing left

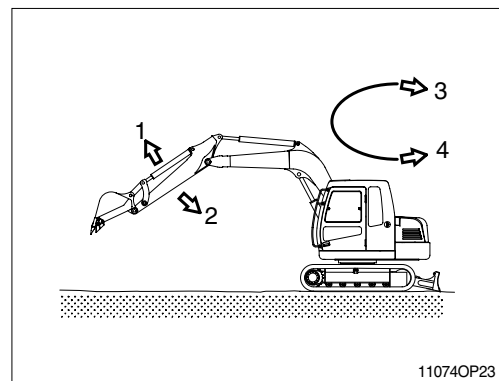

11074OP23

※ **Right control lever**

- 5 Boom lower
- 6 Boom raise
- 7 Bucket roll-out
- 8 Bucket roll-in

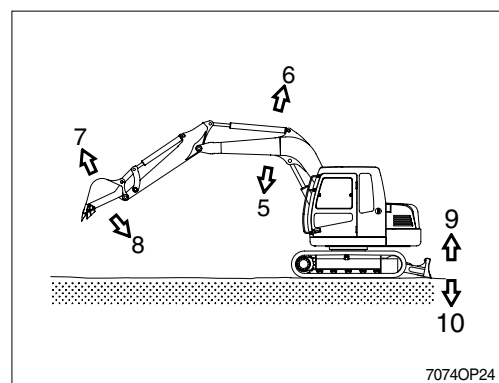

7074OP24

※ **Dozer control lever**

- 9 Dozer blade up
- 10 Dozer blade down

## 6. TRAVELING OF THE MACHINE

### 1) BASIC OPERATION

#### (1) Traveling position

It is the position which the traveling motor is in the rear and the working device is forward.

- ▲ **Be careful as the traveling direction will be reversed when the whole machine is swung 180 degree.**

#### (2) Traveling operation

It is possible to travel by either travel lever or pedal.

- ※ **Do not travel continuously for a long time.**
- ※ **Reduce the engine speed and travel at a low speed when traveling on uneven ground.**

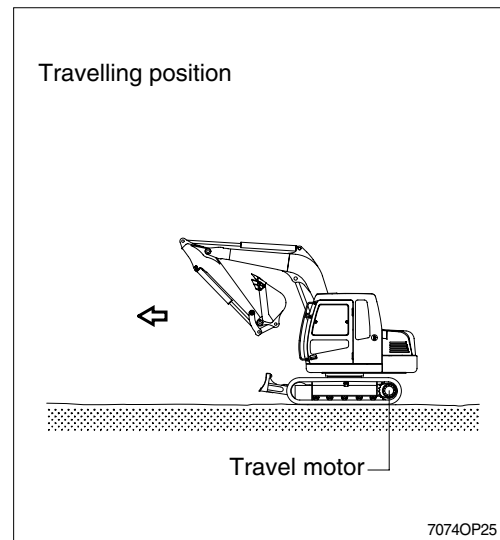

#### (3) Forward and backward traveling

When the left and right travel lever or pedal are pushed at the same time, the machine will travel forward or backward.

- ※ **The speed can be controlled by the operation stroke of lever or pedal and change of direction will be controlled by difference of the left and right stroke.**

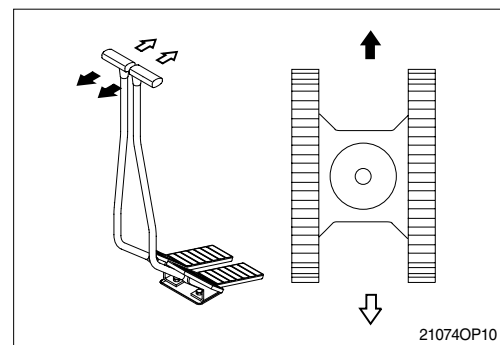

#### (4) Pivot turning

Operating only one side of lever or pedal make the change of direction possible by moving only one track.

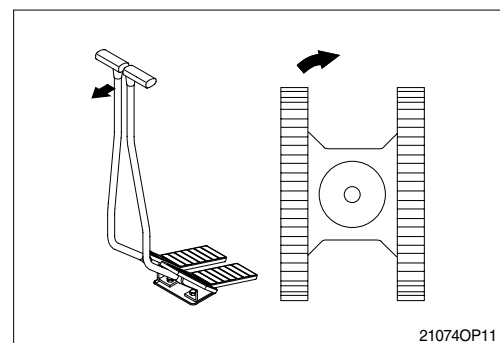

#### (5) Counter rotation

It is to change the direction at the original place by moving the right and left track. Both side of lever or pedal are operated to the other way at the same time.

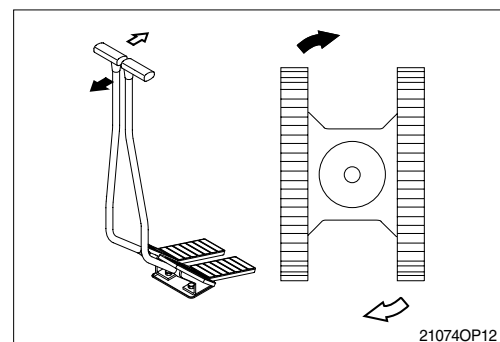

## 2) TRAVELING ON A SLOPE

- (1) Make sure that the travel lever is properly maneuvered by confirming the travel motor is in the right location.
  - (2) Lower the bucket 20 to 30cm(1ft) to the ground so that it can be used as a brake in an emergency.
  - (3) If the machine starts to slide or loses stability, lower the bucket immediately and brake the machine.
  - (4) When parking on a slope, use the bucket as a brake and place blocks behind the tracks to prevent sliding.
- ※ **Machine cannot travel effectively on a slope when the oil temperature is low. Do the warming-up operation when it is going to travel on a slope.**
- ▲ **Be careful when working on slopes. It may cause the machine to lose its balance and turn over.**
- ▲ **Be sure to keep the travel speed switch on the LOW(Turtle mark) while traveling on a slope.**

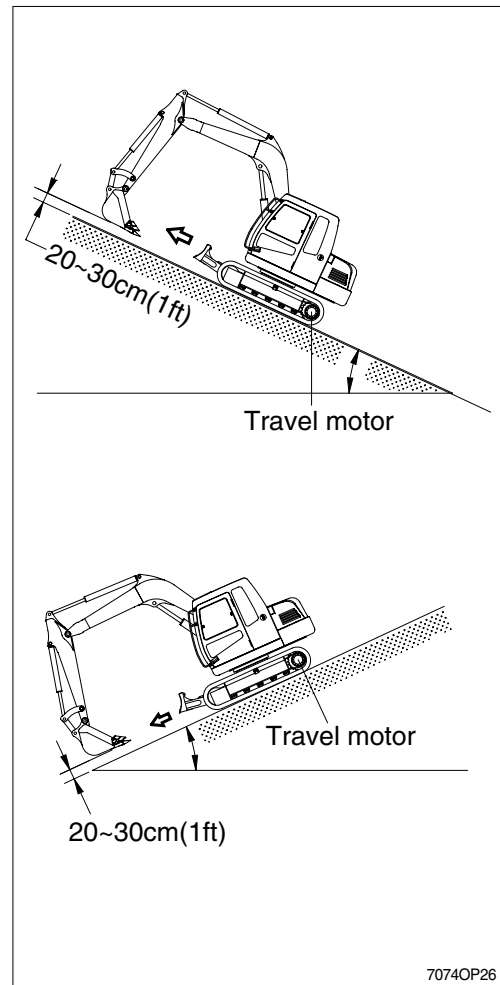

## 3) TRAVELING ON SOFT GROUND

- ※ **If possible, avoid to operate on soft ground.**
- (1) Move forward as far as machine can move.
  - (2) Take care not to go beyond the depth where towing is impossible on soft ground.
  - (3) When driving becomes impossible, lower bucket and use boom and arm to pull the machine. Operate boom, arm, and travel lever at the same time to avoid the machine sinking.

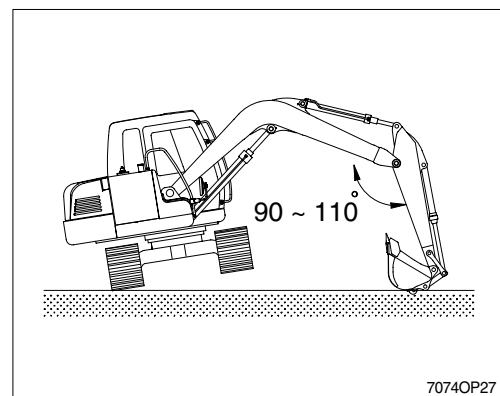

#### 4) TOWING THE MACHINE

Tow the machine as follows when it can not move on it's own.

- (1) Tow the machine by other machine after hook the wire rope to the frame as shown in picture at right.
  - (2) Hook the wire rope to the frame and put a support under each part of wire rope to prevent damage.
- ※ **Never tow the machine using only the tie hole, because this may break.**
  - ▲ **Make sure no personnel are standing close to the tow rope.**

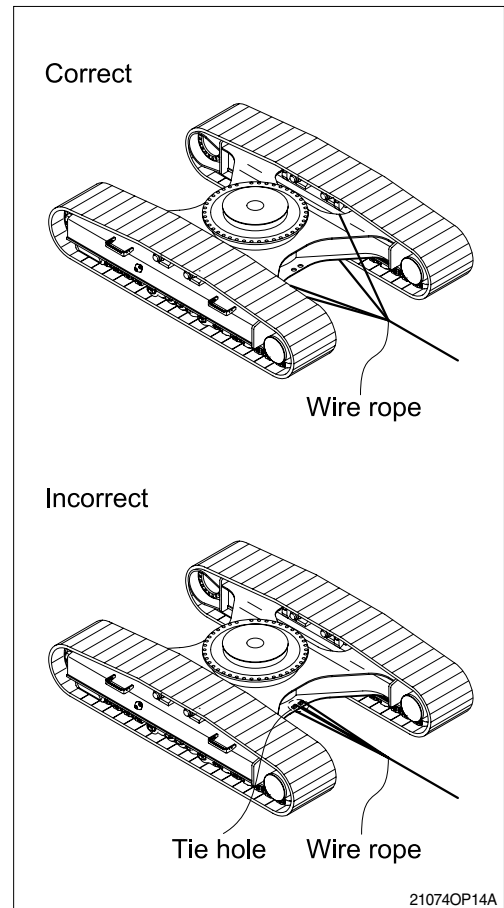

## 7. EFFICIENT WORKING METHOD

- 1) Do the digging work by arm.

Use the pulling force of arm for digging and use together with the digging force of the bucket if necessary.

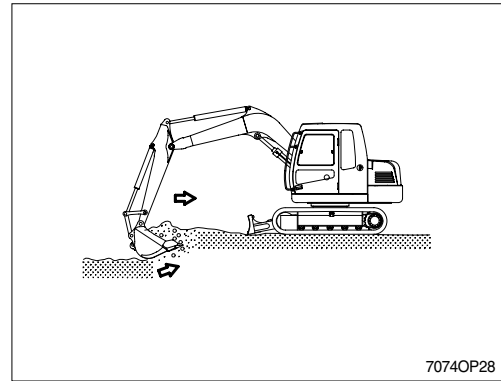

- 2) When lowering and raising the boom operate softly for the beginning and the end.

In particularly, sudden stops while lowering the boom may cause damage to the machine.

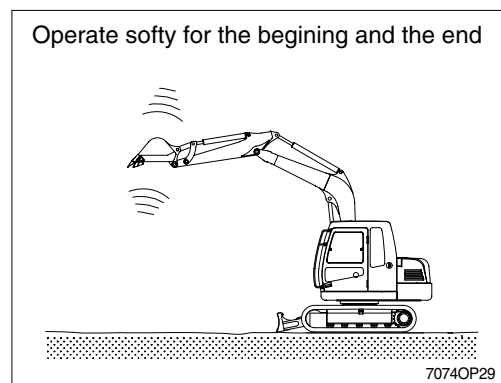

- 3) The digging resistance and wearing of tooth can be reduced by putting the end of bucket tooth to the digging direction.

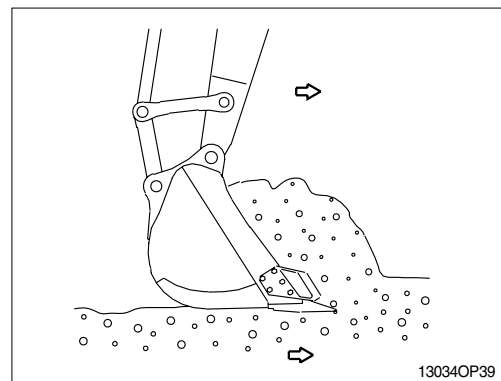

- 4) Set the tracks parallel to the line of the ditch to be excavated when digging ditch. Do not swing while digging.

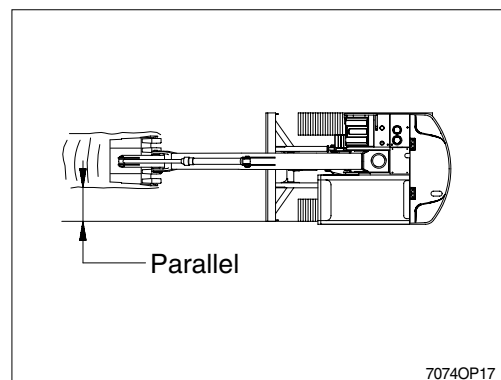



- 5) Dig slowly with keeping the angle of boom and arm, 90-110 degree when maximum digging force is required.

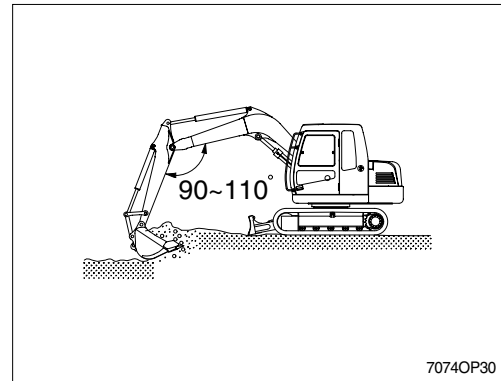

- 6) Operate leaving a small safety margin of cylinder stroke to prevent damage of cylinder when working with the machine.

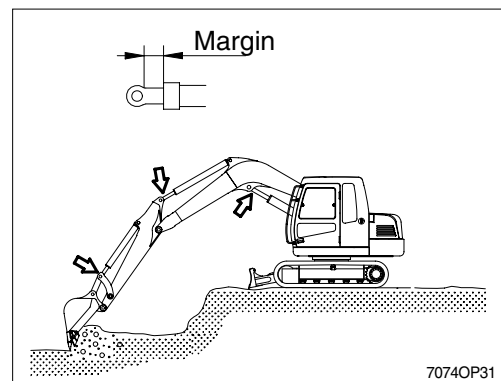

- 7) Keep the bucket to the dumping position and the arm horizontal when dumping the soil from the bucket.  
Operate bucket lever 2 or 3 times when hard to dump.

※ Do not use the impact of bucket tooth when dumping.

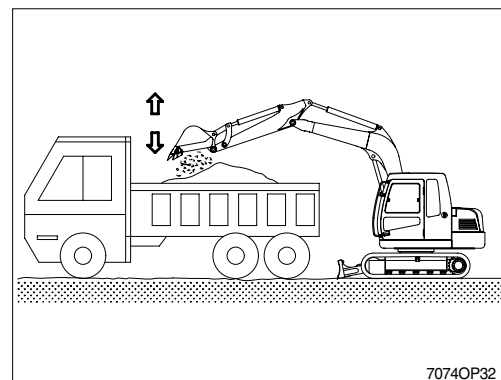

- 8) Operate stop of swing considering the swing slip distance is created by inertia after neutralizing the swing lever.

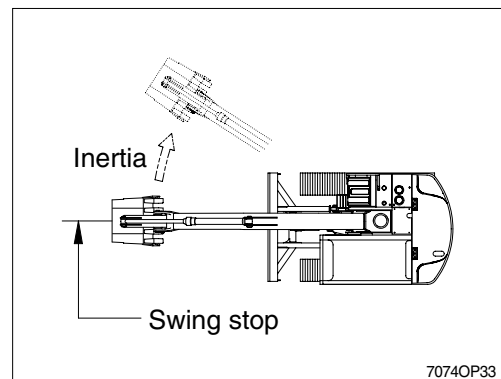

- 9) Do not use the dropping force of the work equipment for digging.  
The machine can be damaged by the impact.

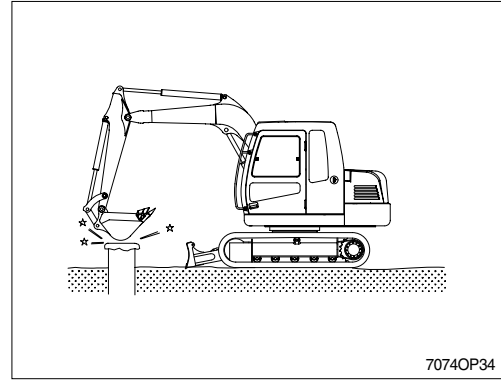

- 10) Do not use the bucket to crack hard objects like concrete or rocks.  
This may break a tooth or pin, or bend boom.

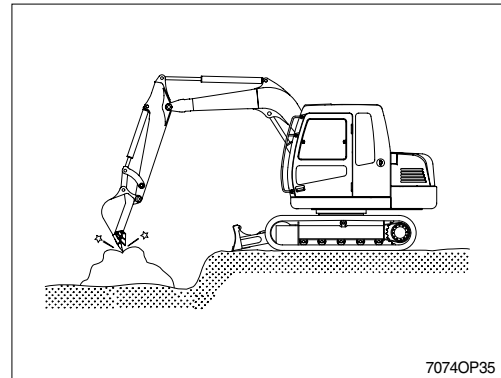

**11) NEVER CARRY OUT EXCESSIVE OPERATIONS**

Operation exceeding machine performance may result in accident or failure.

Carry out lifting operation within specified load limit.

Never carry out operations which may damage the machine such as overload or over-impact-load.

Never travel while carrying a load.

In case you need installing over load warning device for object handling procedure, please contact Hyundai distributor.

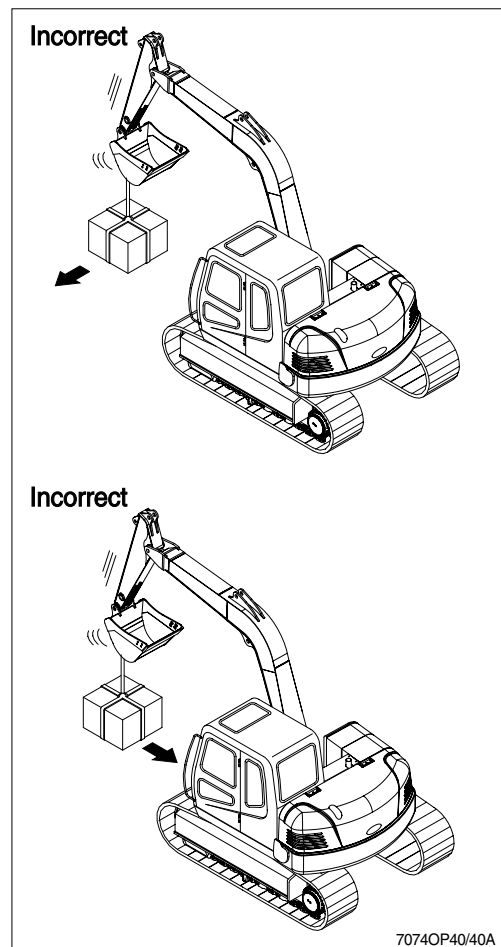

## 12) BUCKET WITH HOOK

When carrying out lifting work, the special lifting hook is necessary.

The following operations are prohibited.

- Lifting loads with a wire rope fitted around the bucket teeth.
- Lifting loads with the wire rope wrapped directly around the boom or arm.

When performing lifting operation, securely hook the wire rope onto the special lifting hook.

When performing lifting operation, never raise or lower a person.

Due to the possible danger of the load falling or of collision with the load, no persons shall be allowed in the working area.

Before performing lifting operation, designate an operation supervisor.

Always execute operation according to his instructions.

- Execute operating methods and procedures under his direction.
- Select a person responsible for signaling. Operate only on signals given by such person.

Never leave the operator's seat while lifting a load.

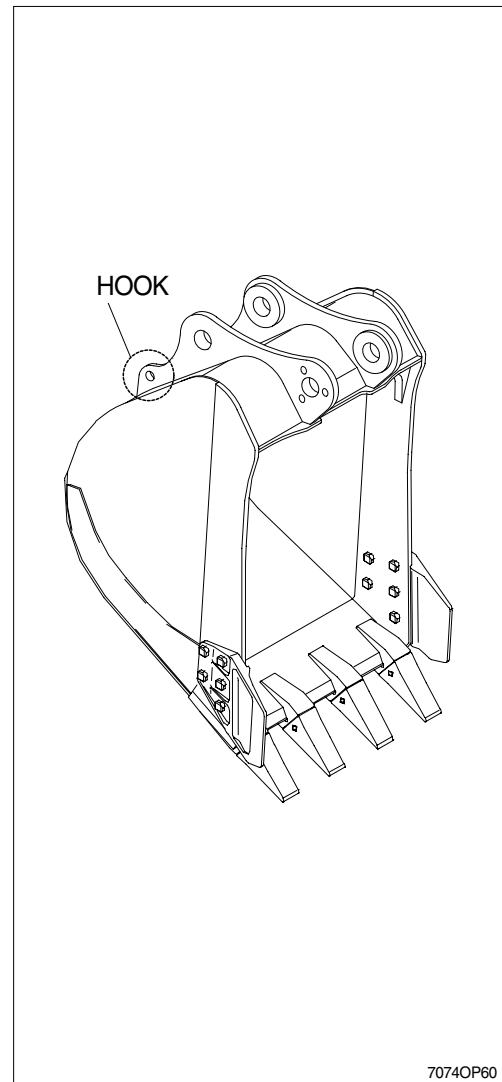

## 8. OPERATION IN THE SPECIAL WORK SITES

### 1) OPERATION THE MACHINE IN A COLD WEATHER

- (1) Use proper engine oil and fuel for the weather.
- (2) Fill the required amount of antifreeze in the coolant.
- (3) Refer to the starting engine in cold weather.  
Start the engine and extend the warming up operation.
- (4) Be sure to open the heater cock when using the heater.
- (5) Always keep the battery completely charged.  
※ **Discharged batteries will freeze more easily than fully charged.**
- (6) Clean the machine and park on the wood plates.

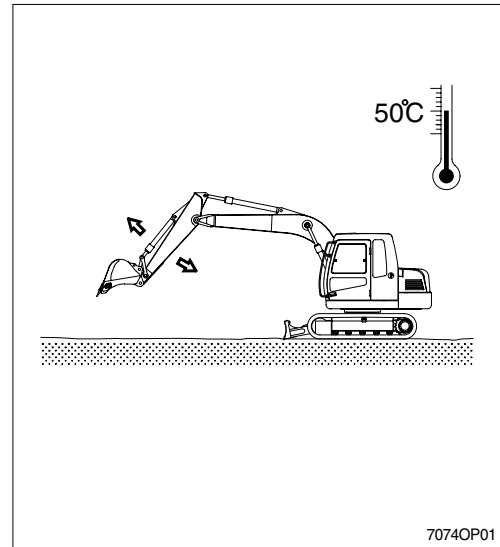

### 2) OPERATION IN SANDY OR DUSTY WORK SITES

- (1) Inspect air cleaner element frequently. Clean or replace element more frequently, if warning lamp comes ON and buzzer sounds simultaneously, regardless of inspection period.  
※ **Replace the inner and outer element after 6 times of cleaning.**
- (2) Inspect radiator frequently, and keep cooling fins clean.
- (3) Prevent sand or dust from getting into fuel tank and hydraulic tank during refilling.
- (4) Prevent sand or dust from penetrating into hydraulic circuit by tightly closing breather cap of hydraulic oil tank. Replace hydraulic oil filter frequently.
- (5) Keep all lubricated part, such as pins and bushings, clean at all times.
- (6) If the air conditioner and heater filters clogged, the heating or cooling capacity will drop. Clean or replace the filter element more frequently.

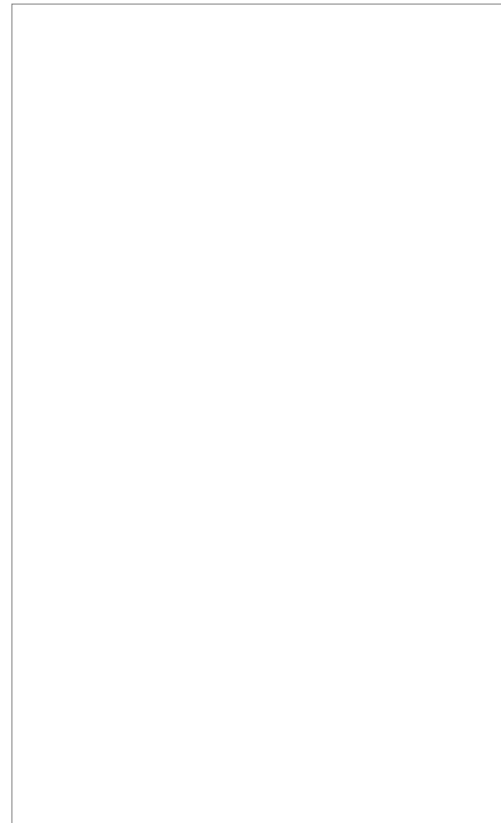

### 3) SEA SHORE OPERATION

- (1) Prevent ingress of salt by securely tightening plugs, cocks and bolts of each part.
- (2) Wash machine after operation to remove salt residue.  
Pay special attention to electrical parts and hydraulic cylinders to prevent corrosion.
- (3) Inspection and lubrication must be carried out more frequently.  
Supply sufficient grease to replace all old grease in bearings which have been submerged in water for a long time.

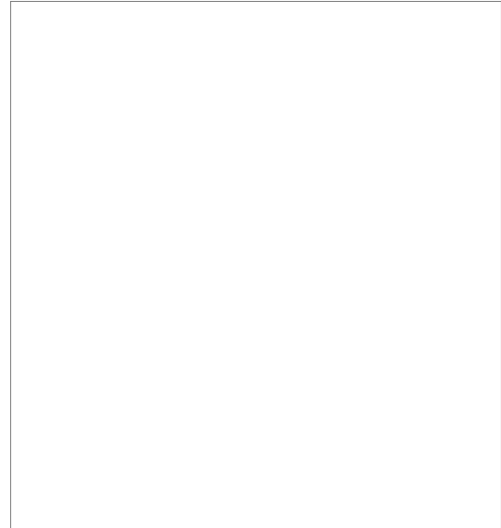

## 9. NORMAL OPERATION OF EXCAVATOR

Followings may occur during operation due to the nature of a hydraulic excavator.

- 1) When rolling in the arm, the roll-in movement stop momentary at point **X** in the picture shown, then recovers speed again after passing point **X**.  
The reason for this phenomenon is that movement by the arm weight is faster than the speed of oil flow into the cylinder.
- 2) When lowering the boom, one may hear continuous sound.  
This is caused by oil flow in the valve.
- 3) Overloaded movement will produce sound caused by the relief valves, which are for the protection of the hydraulic systems.
- 4) When the machine is started swing or stopped, a noise near the swing motor may be heard. The noise is generated when the brake valve relieves.

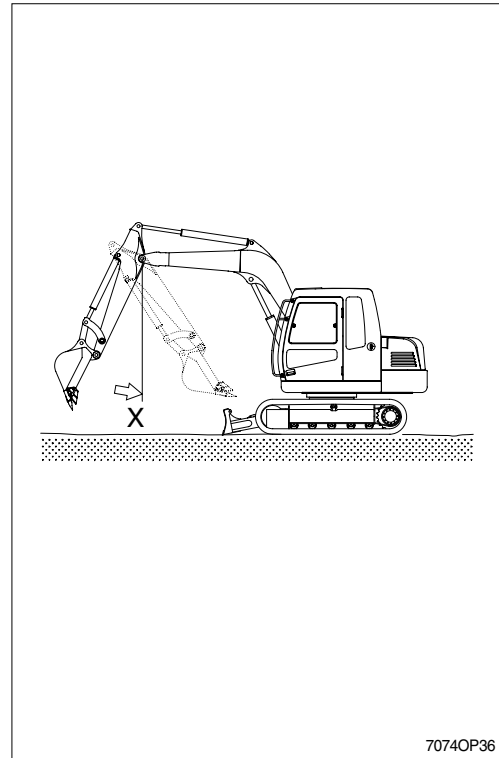

## 10. ATTACHMENT LOWERING (When engine is stopped)

1) On machines equipped with an accumulator, for a short time (within 2 minutes) after the engine is stopped, the attachment will lower under its own weight when the attachment control lever is shifted to LOWER. That happens only starting switch ON position and safety lever UNLOCK position. After the engine is stopped, set the safety lever to the LOCK position.

**▲ Be sure no one is under or near the attachment before lowering the boom.**

2) The accumulator is filled with high-pressure nitrogen gas, and it is extremely dangerous if it is handled in the wrong way. Always observe the following precautions.

**▲ Never make any hole in the accumulator expose it to flame or fire.**

**▲ Do not weld anything to the accumulator.**

**※ When carrying out disassembly or maintenance of the accumulator, or when disposing of the accumulator, it is necessary to release the gas from the accumulator. A special air bleed valve is necessary for this operation, so please contact your Hyundai distributor.**

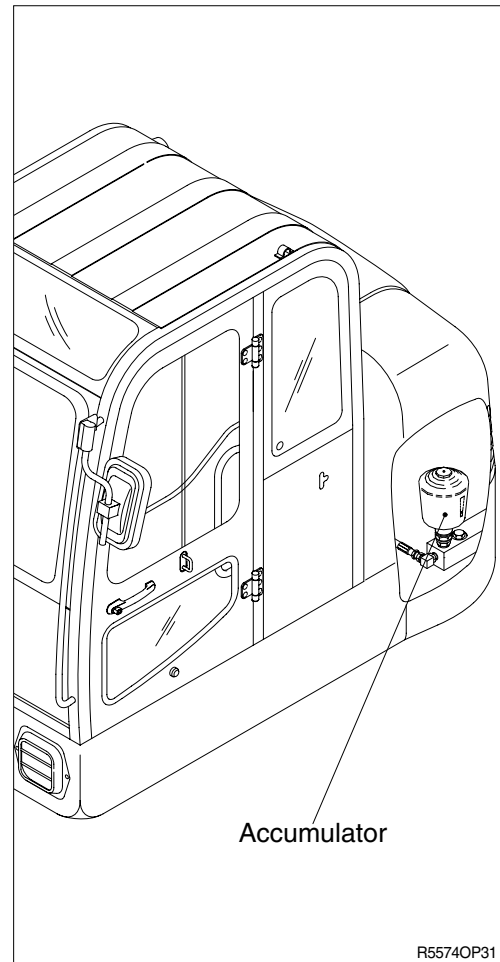

R55740P31

## 11. STORAGE

Maintain the machine taking care of following to prevent the deterioration of machine when storing the machine for a long time, over 1 month.

### 1) CLEANING THE MACHINE

Clean the machine. Check and adjust tracks.  
Grease each lubrication part.

### 2) LUBRICATION POSITION OF EACH PART

Change all oil.

※ Be particularly careful when you reuse the machine.

As oil can be diluted during storage.

Apply an anticorrosive lubricant on the exposed part of piston rod of cylinder and in places where the machine rusts easily.

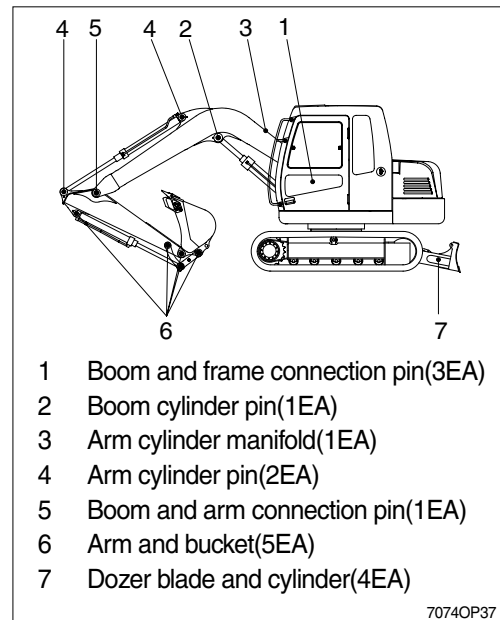

### 3) MASTER SWITCH

Turn OFF the master switch mounted in the tool box and store the machine.

4) Be sure to mix anticorrosive antifreezing solution in the radiator.

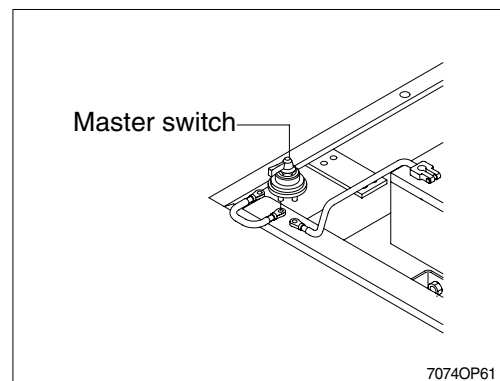

### 5) PREVENTION OF DUST AND MOISTURE

Keep machine dry. Store the machine setting wood on the ground.

※ Cover exposed part of piston rod of cylinder.

※ Lower the bucket to the ground and set a support under track.

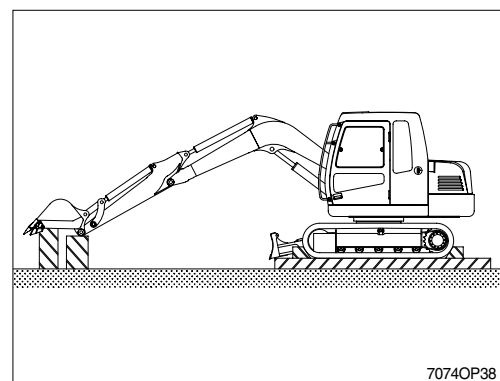



## 6) DURING STORAGE

Start engine and move the machine and work equipment once a month and apply lubrication to each part.

- ※ Check the level of engine oil and coolant and fill if required when starting engine.
- ※ Clean the anticorrosive on the piston rod of cylinder.
- ※ Operate the machine such as traveling, swing and work equipment operation to make sure enough lubrication of all functional components.

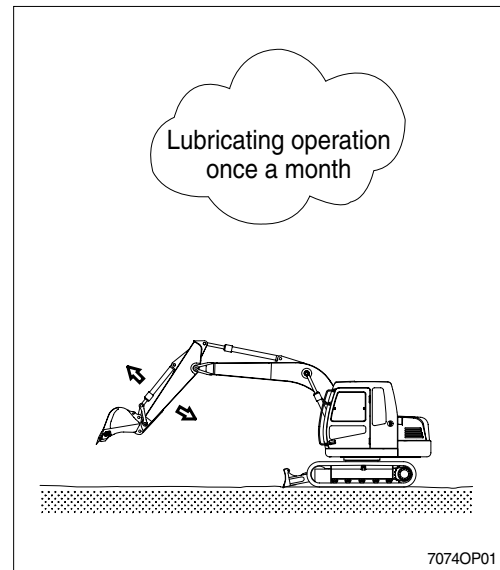

## 12. RCV LEVER OPERATING PATTERN(STD)

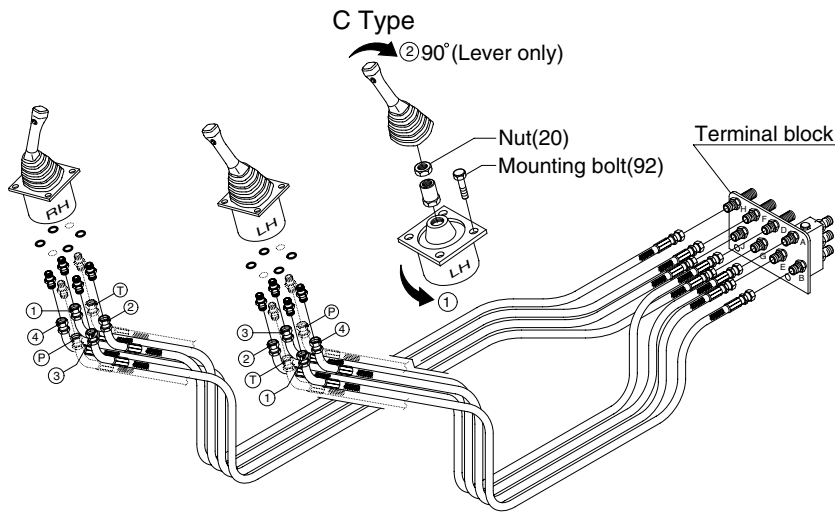

※ Whenever a change is made to the machine control pattern also exchange the pattern label in the cab to match the new pattern.

110740P40

Pattern	Operation		Control function	Hose connection(Port)			
	Left	Right		RCV lever	Change of MCV port		
					From	To	
ISO Type			Left	Arm out	②	D	-
				Arm in	④	E	-
				Swing right	③	A	-
				Swing left	①	B	-
			Right	Boom lower	④	J	-
				Boom raise	②	H	-
				Bucket out	①	F	-
Hyundai			Left	Boom lower	②	D	J
				Boom raise	④	E	H
				Swing right	③	A	-
			Right	Swing left	①	B	-
				Arm out	④	J	D
				Arm in	②	H	E
				Bucket out	①	F	-
A Type			Left	Bucket in	③	G	-
				Boom lower	②	D	J
				Boom raise	④	E	H
			Right	Swing right	③	A	-
				Swing left	①	B	-
				Arm out	④	J	D
				Arm in	②	H	E
B Type			Left	Bucket out	①	F	-
				Bucket in	③	G	-
				Boom lower	②	D	J
			Right	Boom raise	④	E	H
				Swing right	①	F	A
				Swing left	③	G	B
				Arm in	②	H	E
C Type			Left	① Loosen the RCV lever mounting bolt(21) and rotates lever assy 90° counterclockwise; then install. ② To put lever in correct position, disassemble nut(20) and rotates only lever 90° clockwise.			
				Right	Same as ISO type		

## RCV LEVER OPERATING PATTERN(option, A type)

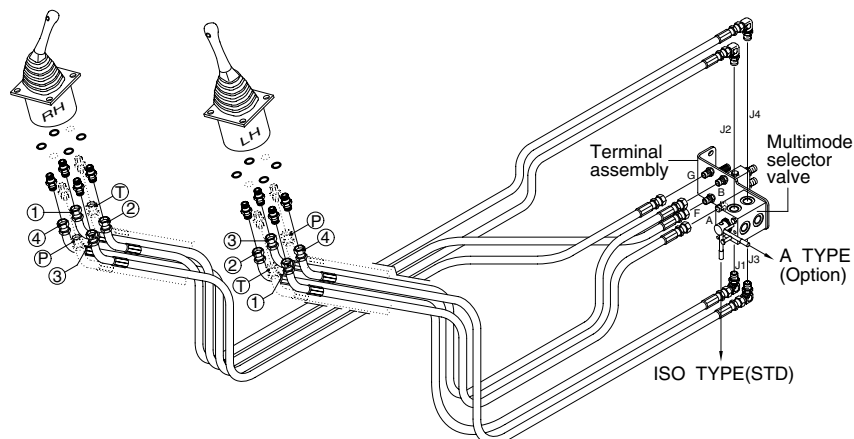

1607A4OP94A

Pattern	Operation		Control function	Hose connection(Port)			
	Left	Right		RCV lever	MCV port		
A Type			Left	1 Boom lower	②	J1	
				2 Boom raise	④	J3	
				3 Swing right	③	B	
				4 Swing left	①	A	
	Right			Right	5 Arm out	④	J2
					6 Arm in	②	J4
					7 Bucket out	①	F
					8 Bucket in	③	G

1) The machine control pattern can easily be changed from the "ISO" type to the "A" type by changing the position of the lever.

**▲ Before starting the machine, check the lever position of multimode selector valve and actual operating of attachment.**

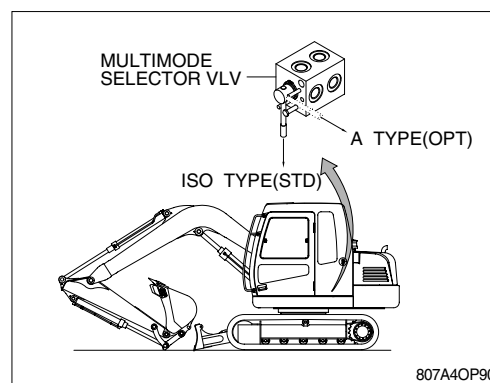

807A4OP90

### 2) Change of operating pattern(ISO → A type)

- (1) Loosen bolt(11).
- (2) Move lever from the "ISO" type to "A" type position.
- (3) After setting the lever, tighten bolt to secure lever.

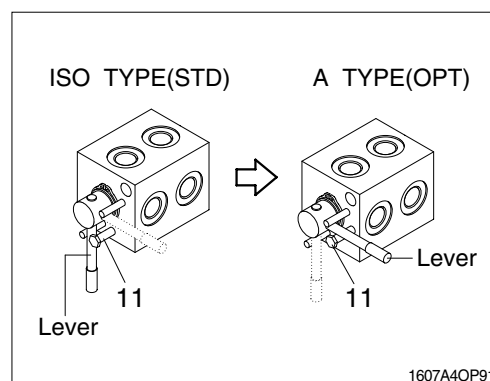

1607A4OP91

### 13. SWITCHING HYDRAULIC ATTACHMENT CIRCUIT

- 1) The combined hydraulic attachment circuit is capable of providing single action or double action.
- 2) The position of 3 way valve selects the single action hydraulic attachment circuit or the double action hydraulic attachment circuit.

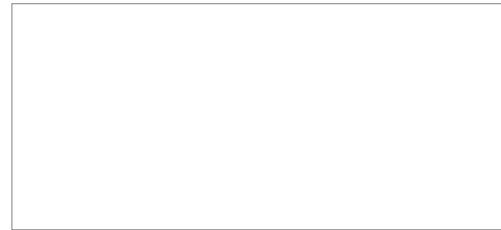

- 3) Before you change the flow mode of hydraulic attachment circuit, place the machine in the servicing position as shown. Stop the engine.

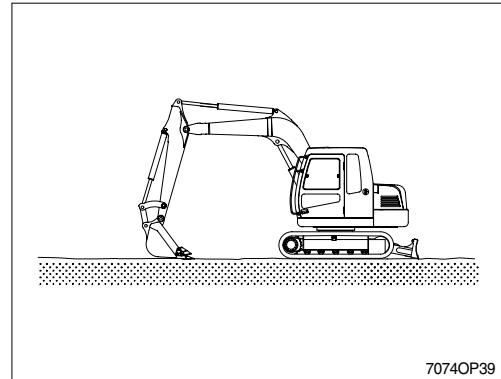

- 4) Use the manual lever to turn the 3 way valve. Make sure that you fully turn the valve until the valve stops.

**(1) One way flow**(Hydraulic breaker)

Position the manual lever parallel to the piping (  ).

**(2) Two way flow**(Clamshell or shear)

Position the manual lever perpendicular to the piping(  ).

