

# CONTENTS

Foreword .....	0-1	7. Efficient working method .....	4-16	
Before servicing this machine .....	0-2	8. Operation in the special work sites .....	4-20	
EC regulation approved .....	0-3	9. Normal operation of excavator .....	4-22	
Table to enter S/No and distribution .....	0-4	10. Attachment lowering .....	4-23	
Safety labels .....	0-5	11. Storage .....	4-24	
Machine data plate .....	0-19	12. RCV lever operating pattern .....	4-26	
Guide (direction, S/No, symbol) .....	0-20	13. Switching hydraulic attachment circuit .....	4-28	
		14. Regeneration system .....	4-29	
<b>SAFETY HINTS</b>				
1. Before operating the machine .....	1-1	<b>TRANSPORTATION</b>		
2. During operating the machine .....	1-16	1. Preparation for transportation .....	5-1	
3. During maintenance .....	1-23	2. Dimension and weight .....	5-2	
4. Parking .....	1-26	3. Loading the machine .....	5-4	
		4. Fixing the machine .....	5-6	
		5. Loading and unloading by crane .....	5-7	
<b>SPECIFICATIONS</b>				
1. Major components .....	2-1	<b>MAINTENANCE</b>		
2. Specifications .....	2-2	1. Instruction .....	6-1	
3. Working range .....	2-3	2. Tightening torque .....	6-6	
4. Weight .....	2-4	3. Fuel, coolant and lubricants .....	6-9	
5. Lifting capacities .....	2-5	4. Maintenance check list .....	6-11	
6. Bucket selection guide .....	2-6	5. Maintenance chart .....	6-16	
7. Undercarriage .....	2-7	6. Service instruction .....	6-18	
8. Specification for major components .....	2-9	7. Electrical system .....	6-45	
9. Recommended oils .....	2-12	8. Air conditioner and heater .....	6-48	
<b>CONTROL DEVICES</b>				
1. Cab devices .....	3-1	<b>TROUBLESHOOTING GUIDE</b>		
2. Cluster .....	3-2	1. Engine .....	7-1	
3. Switches .....	3-27	2. Electrical system .....	7-2	
4. Levers and pedals .....	3-32	3. Others .....	7-3	
5. Air conditioner and heater .....	3-34	<b>HYDRAULIC BREAKER AND QUICK CLAMP</b>		
6. Others .....	3-38	1. Selecting hydraulic breaker .....	8-1	
<b>OPERATION</b>				
1. Suggestion for new machine .....	4-1	2. Circuit configuration .....	8-2	
2. Check before starting the engine .....	4-2	3. Maintenance .....	8-3	
3. Starting and stop the engine .....	4-3	4. Precaution while operating the breaker .....	8-4	
4. Mode selection system .....	4-7	5. Quick clamp .....	8-6	
5. Operation of the working device .....	4-12	<b>OTHERS</b>		
6. Traveling of the machine .....	4-13	1. Semi auto grease lubrication system .....	9-1	
		<b>INDEX</b> .....		10-1

## FOREWORD

This manual contains a number of instructions and safety recommendations regarding driving, handling, lubrication, maintenance, inspection and adjustment of the excavator.

The manual is to promote safety maintenance and enhance machine performance.

Keep this manual handy and have all personnel read it periodically.

If you sell the machine, be sure to give this manual to the new owners.

This machine complies with EC directive "2006/42/EC".

1. **Read** and **understand** this manual before operating the machine.

This operator's manual may contain attachments and optional equipment that are not available in your area. Please consult your local Hyundai distributor for those items you require.

Improper operation and maintenance of this machine can be hazardous and could result in serious injury or death.

Some actions involved in operation and maintenance of the machine can cause a serious accident, if they are not done in a manner described in this manual.

The procedures and precautions given in this manual apply only to intended uses of the machine.

If you use your machine for any unintended uses that are not specifically prohibited, you must be sure that it is safe for you and others. In no event should you or others engage in prohibited uses of actions as described in this manual.

2. **Inspect** the jobsite and **follow** the safety recommendations in the **safety hints** section before operating the machine.

3. Use **genuine Hyundai spare parts** for the replacement of parts.

We expressly point out that Hyundai will not accept any responsibility for defects resulting from non-genuine parts or non workmanlike repair.

In such cases Hyundai cannot assume liability for any damage.

Continuing improvements in the design of this machine can lead to changes in detail which may not be reflected in this manual. Consult Hyundai or your Hyundai distributor for the latest available information for your machine or for questions regarding information in this manual.

## BEFORE SERVICING THIS MACHINE

It is the responsibility of the owner and all service and maintenance personnel to avoid accidents and serious injury by keeping this machine properly maintained.

It also is the responsibility of the owner and all service and maintenance personnel to avoid accidents and serious injury while servicing the machine.

No one should service or attempt to repair this machine without proper training and supervision.

All service and maintenance personnel should be thoroughly familiar with the procedures and precautions contained in this manual.

All personnel also must be aware of any federal, state, provincial or local laws or regulations covering the use and service of construction equipment.

The procedures in this manual do not supersede any requirements imposed by federal, state, provincial or local laws.

Hyundai can not anticipate every possible circumstance or environment in which this machine may be used and serviced.

All personnel must remain alert to potential hazards.

Work within your level of training and skill.

Ask your supervisor if you are uncertain about a particular task. Do not try to do too much too fast.

Use your common sense.

### ※ How to adjust the language of cluster

User can select preferable language and all displays are changed the selected language.



※ Please refer to the page 3-24 for the cluster.

## EC REGULATION APPROVED

- Noise level (EN474-1 : 2006 and 2000/14/EC) are as followings.

LWA : 106 dB (EU only)

LPA : 73 dB

- The value of vibrations transmitted by the operator's seat are lower than standard value of (EN474-1 : 2006 and 2002/44/EC)

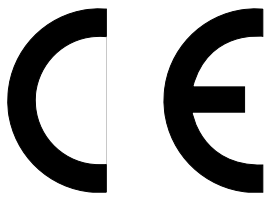

## EC Declaration of conformity - update 04/01/'10

1. We hereby declare that the following machine comply with the machine directive 2006/42/EC, EMC-directive 2004/108/EC, Non-road mobile machinery emission directive 97/68/EC (amended by 2002/88/EC, 2004/26/EC, 2006/105/EC) and noise emission 2000/14/EC (amended by 2005/88/EC).

Excavator	Model :	*****
	Serial Nr. :	***

2. Manufacturer  
 HYUNDAI CONSTRUCTION EQUIPMENT CO., LTD.  
 12th Fl., Hyundai Bldg. 75, Yulgok-ro, Jongno-gu,  
 Seoul 03058, Korea

Authorized representative : Owner of the technical file for machine production. (TCF : Technical Construction File)	HYUNDAI CONSTRUCTION EQUIPMENT EUROPE N.V. Hyundailaan 4, 3980 Tessenderlo Belgium
--	--

3. Harmonized European directives : EN474-1:2006 +A1:2009, EN474-5: 2006, EN ISO 12100-1:2003, EN ISO 12100-2:2003, EN ISO 2867:2008, EN ISO 7096:2008, EN ISO 6683:2008, EN ISO 2860:2008, EN ISO 6682:2008, EN ISO 3744:2009, EN 982:1996+A1:2008, EN ISO 3457:2008 EN ISO 2860:2008, EN ISO 7096:2008, ISO 5006: 2006

4. Noise level :

Certain n° :	e13*2000/14*2005/88*0059*08
Date :	2009-06-17
Conformity assessment procedure :	Attachment VIII following the periodical inspection on technical extended with "Information on the scope of delivery" by TÜV Rheinland.
Authorized entity :	Société Nationale de Certification et d'Homologation s.à r.l CE0499 11, route de Luxembourg 5230 Sandweiler Luxemburg
Engine power :	*** kW
Guaranteed sound power level :	*** dB (A)

5. Remarks

\*\*\*\*\*

Managing Director

Tessenderlo, Belgium

\*\*/\*\*/\*\*\*\*

**TABLE TO ENTER SERIAL NO. AND DISTRIBUTOR**

Machine Serial No.	
Engine Serial No.	
Manufacturing year	
Manufacturer Address	HYUNDAI CONSTRUCTION EQUIPMENT CO., LTD. 12th Fl., Hyundai Bldg. 75, Yulgok-ro, Jongno-gu, Seoul 03058, Korea
Distributor for U.S.A Address	HYUNDAI CONSTRUCTION EQUIPMENT U.S.A, Inc. 6100 Atlantic Boulevard Norcross GA 30071 U.S.A
Distributor for Europe Address	HYUNDAI CONSTRUCTION EQUIPMENT EUROPE N. V. Hyundailaan 4 3980 Tessenderlo Belgium
Dealer Address	

# SAFETY LABELS

## 1. LOCATION

Always keep these labels clean. If they are lost or damaged, attach them again or replace them with a new label.

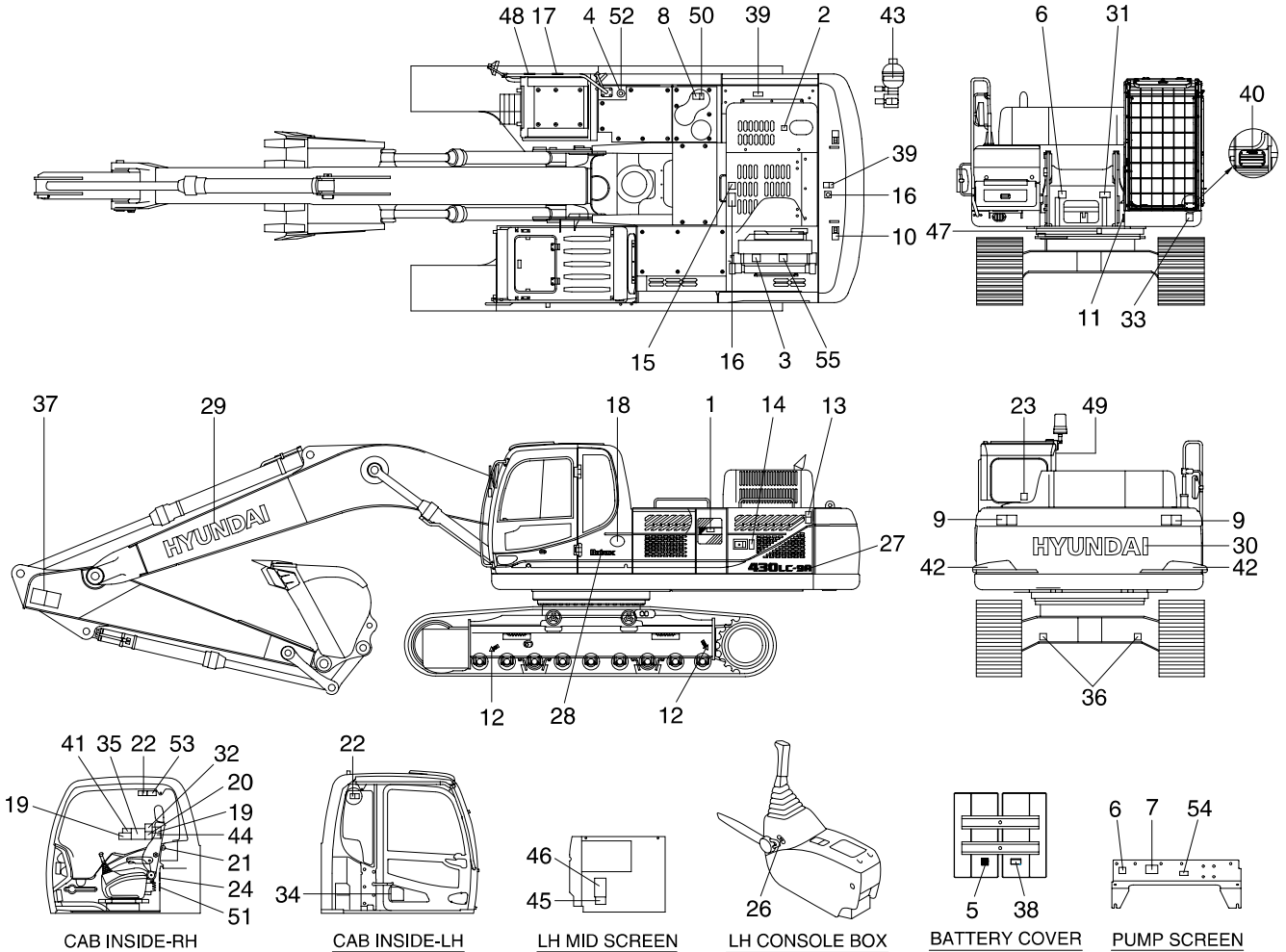

4309A0SL01

- |                         |  |  |
|-------------------------|--|--|
| 1 Air cleaner filter    | 19 Control ideogram                    | 38 Electric welding                        |
| 2 Turbocharger cover    | 20 Ref operator's manual-cab RH pillar | 39 Falling                                 |
| 3 Radiator cap          | 21 Hammer                              | 40 FOPS FOG plate                          |
| 4 Fueling               | 22 Safety front window                 | 41 Caution (water separator, turbocharger) |
| 5 Battery accident      | 23 Safety rear window                  | 42 Reflecting                              |
| 6 High pressure hose    | 24 Air conditioner filter              | 43 Accumulator                             |
| 7 Hydraulic oil level   | 26 Safety lever                        | 44 Machine control pattern-cab             |
| 8 Hydraulic oil lub     | 27 Model name                          | 45 RCV lever pattern                       |
| 9 Keep clear-rear       | 28 Logo (ROBEX)                        | 46 Machine control pattern                 |
| 10 Lifting eye          | 29 Trade mark (boom)                   | 47 Swing bearing grease                    |
| 11 Name plate           | 30 Trade mark (CWT)                    | 48 Battery position                        |
| 12 Slinging ideogram    | 31 Reduction gear grease               | 49 Beacon lamp                             |
| 13 Keep clear-side      | 32 Clamp locking                       | 50 Fuel shut off                           |
| 14 Stay fix             | 33 Noise level LWA                     | 51 MCU/ECM connector                       |
| 15 Shearing-engine hood | 34 Service instruction                 | 52 Ultra low sulfur diesel                 |
| 16 No step              | 35 Lifting chart                       | 53 Rops plate                              |
| 17 Transporting         | 36 Tie                                 | 54 Lubrication oil                         |
| 18 Low emission engine  | 37 Keep clear-Boom/arm                 | 55 Surge tank                              |

## 2. DESCRIPTION

There are several specific warning labels on this machine please become familiarized with all warning labels.

Replace any safety label that is damaged, or missing.

### 1) AIR CLEANER FILTER (item 1)

This warning label is positioned on the air cleaner cover.

- ※ Periodic and proper inspection, cleaning and change of elements prolong engine life time and maintain the good performance of engine.

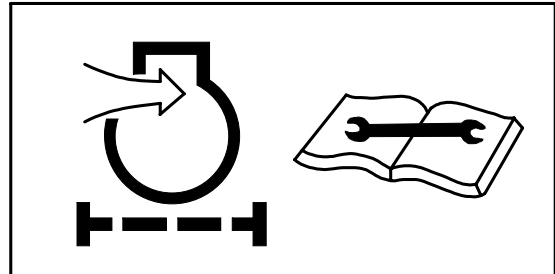

21070FW01

### 2) TURBOCHARGER COVER (item 2)

This warning label is positioned on the turbocharger cover.

- ▲ Do not touch turbocharger or it may cause severe burn.



21070FW02

### 3) RADIATOR CAP (item 3)

This warning label is positioned on the radiator.

- ▲ Never open the filler cap while engine running or at high coolant temperature.

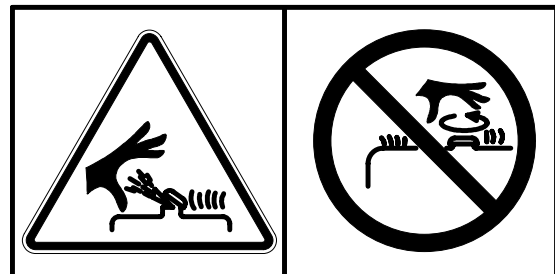

14070FW03

### 4) FUELING (item 4)

This warning label is positioned on the right side of fuel filler neck.

- ▲ Stop the engine when refueling. All lights or flames shall be kept at a safe distance while refueling.

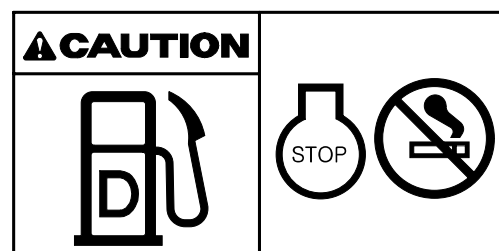

21070FW04



### 5) BATTERY ACCIDENT (item 5)

This warning label is positioned on the battery cover.

- ▲ Electrolyte containing sulfuric acid cause severe burns. Avoid being in contact with skin, eyes or clothes. In the event of accident flush with sufficient water, call a physician immediately.
- ※ Maintain the electrolyte at the recommended level. Add distilled water to the battery only when starting up, never when shutting down.  
With electrolyte at proper level, less space may cause the gases to be accumulated in the battery.
- ▲ Extinguish all smoking materials and open flames before checking the battery.
- ▲ Do not use matches, lighters or torches as a light source near the battery for the probable presence of explosive gas.
- ▲ Do not allow unauthorized personnel to change the battery or to use booster cables.
- ▲ For safety from electric shock, do not battery terminal with a wet hand.

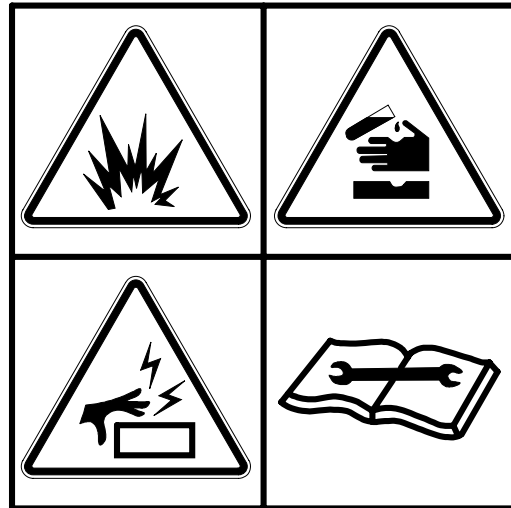

36070FW05

### 6) HIGH PRESSURE HOSE (item 6)

This warning label is positioned on the screen plate.

- ▲ Escaping fluid under pressure can penetrate the skin causing serious injury.
- ※ Study the service manual before service job.



14070FW29

### 7) HYDRAULIC OIL LEVEL (item 7)

This warning label is positioned on the screen plate.

- ▲ Place the bucket on the ground whenever servicing the hydraulic system.
- ※ Check oil level on the level gauge.
- ※ Refill the recommended hydraulic oil up to specified level if necessary.

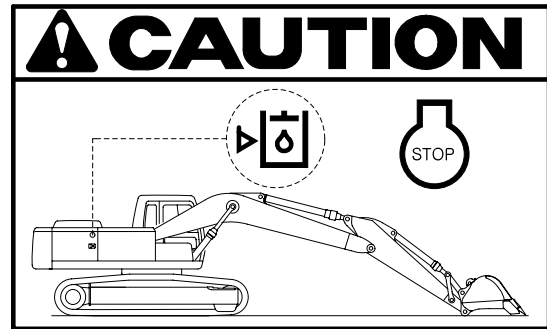

21070FW07

### 8) HYDRAULIC OIL LUBRICATION (item 8)

This warning label is positioned on the top of the hydraulic tank.

- ※ Do not mix with different brand oils.
- ▲ Never open the filler cap while high temperature.
- ▲ Loosen the cap slowly and release internal pressure completely.



14070FW08

### 9) KEEP CLEAR (item 9)

This warning label is positioned on the rear of counterweight.

- ▲ To prevent serious personal injury or death keep clear of machine swing radius.
- ▲ Do not deface or remove this label from the machine.

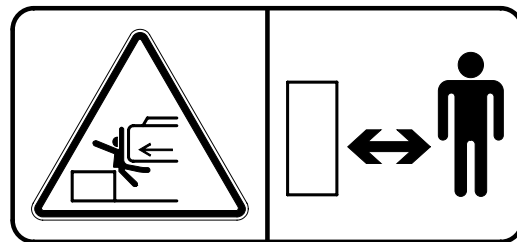

21090FW09

### 10) LIFTING EYE (item 10)

This warning label is positioned on the counterweight.

- ▲ Do not lift the machine by using lifting eyes on the counterweight or the lifting eyes may be subject to overload causing its breaking and possible personal injury.
- ※ See page 5-7 for proper lifting method of the machine.

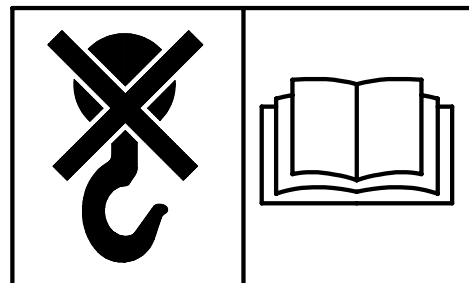

21070FW10

11) **SIDE KEEP CLEAR** (item 13)

This warning label is positioned on the side of LH rear side cover.

- ⚠ **To prevent serious personal injury or death keep clear of machine swing radius.**
- ⚠ **Do not deface or remove this label from the machine.**

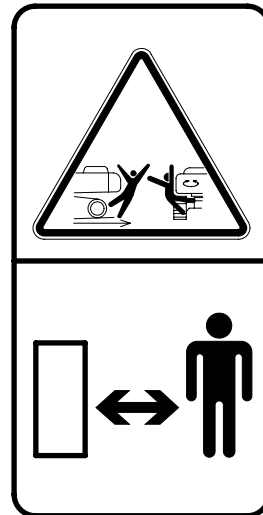

21070FW13

12) **STAY FIX** (item 14)

This warning label is positioned on the side cover.

- ⚠ **Be sure to support the stay when the door needs to be opened.**
- ⚠ **Be careful that the opened door may be closed by the external or natural force like strong wind.**

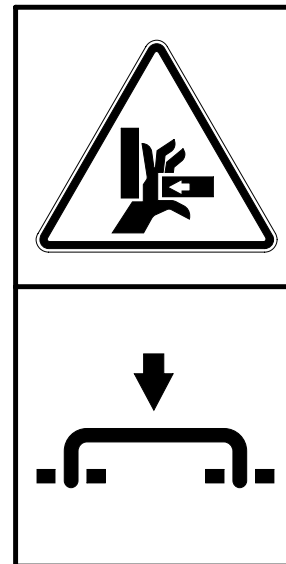

21070FW14

13) **SHEARING-ENGINE HOOD** (item 15)

This warning label is positioned on the engine hood.

- ⚠ **Don't open the engine hood during the engine's running.**
- ⚠ **Don't touch exhaust pipe or it may cause severe burn.**

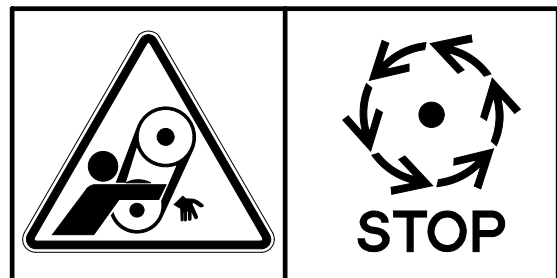

21070FW15

14) **NO STEP** (item 16)

This warning label is positioned on the engine hood and counterweight.

- △ **Don't step on the engine hood and counterweight.**

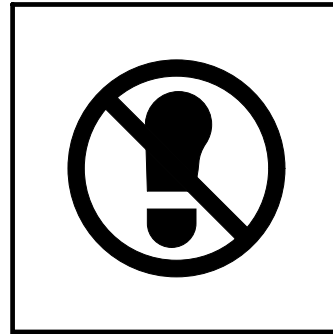

21070FW16

15) **TRANSPORTING** (item 17)

This warning label is positioned right side of upper frame.

- ▲ **Study the operator's manual before transporting the machine, if provided and tie down arm and track to the carrier with lashing wire.**  
See page 5-6 for details.

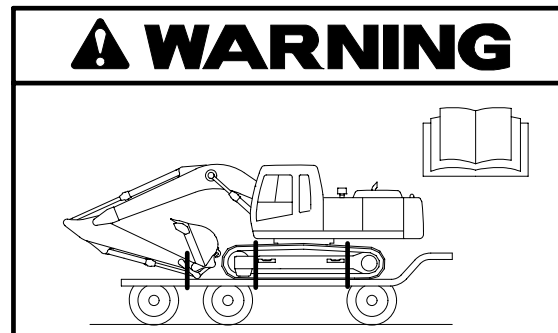

14070FW17

16) **CONTROL IDEOGRAM** (item 19)

This warning label is positioned in right window of the cab.

- ▲ **Check the machine control pattern for conformance to pattern on this label. If not, change label to match pattern before operating machine.**
- ▲ **Failure to do so could result in injury or death.**  
See page 4-12 for details.

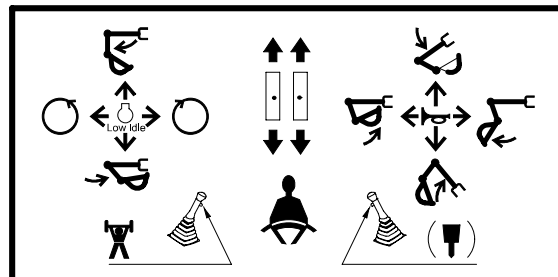

36070FW19

### 17) REF OPERATOR MANUAL (item 20)

This warning label is positioned on the right side window of the cab.

#### (1) Ref operator manual

- ▲ Study the operator's manual before starting and operating machine.

#### (2) Max height

- ▲ Serious injury or death can result from contact with electric lines.

An electric shock being received by merely coming into the vicinity of an electric lines, the minimum distance should be kept considering the supply voltage as page 1-7.

#### (3) Interference

- ▲ Be careful to operate machine equipped with quick clamp or extensions. Bucket may hit cab or boom, boom cylinders when it reached vicinity of them.

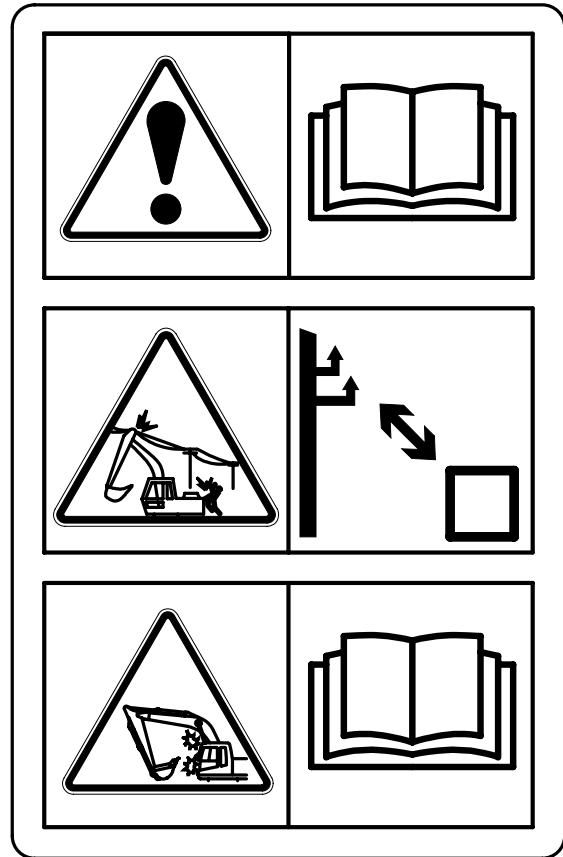

2609A0SL05

### 18) SAFETY FRONT WINDOW (item 22)

This warning label is positioned on the both side window of the cab.

- ▲ Be careful that the front window may be promptly closed.

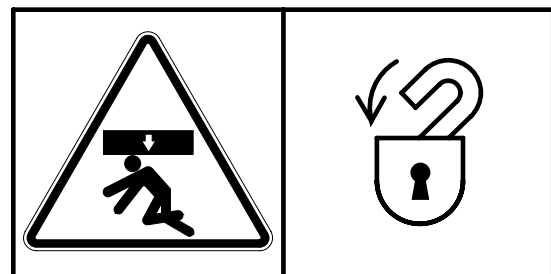

21070FW24

### 19) SAFETY REAR WINDOW (item 23)

This warning label is positioned on the inside of rear window.

- ※ The rear window serves us an alternate exit.
- ※ To remove rear window, pull the ring and push out the glass.



2609A0SL02

**20) AIR CONDITIONER FILTER (item 24)**

This warning label is positioned on the air conditioner cover.

- ※ **Periodic and proper inspection, cleaning and change of filter prolong air conditioner life time and maintain good performance.**

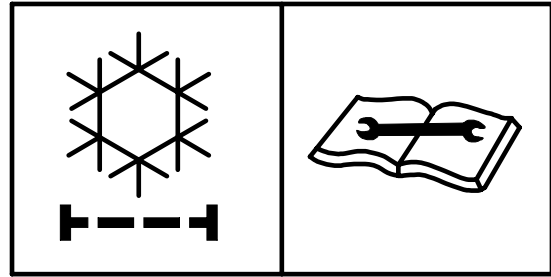

21070FW26

**21) SAFETY LEVER (item 26)**

This warning label is positioned on the cover of the safety lever.

- ▲ **Before you get off the machine be sure to place the safety lever LOCKED position.**

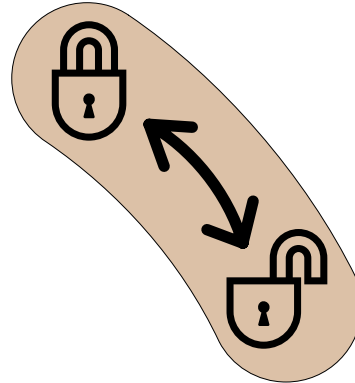

30007A1FW07A

**22) REDUCTION GEAR GREASE (item 31)**

This warning label is positioned in the front of upper frame.

- ▲ **Grease is under high pressure. Grease coming out of the grease plug under pressure can penetrate the body causing injury or death.**

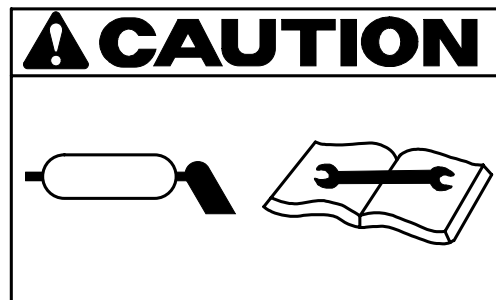

21070FW35

**23) CLAMP LOCKING (item 32)**

This warning label is positioned on the right side window of cab.

- ▲ **Serious injury or death can result from dropping bucket.**
- ▲ **Operating the machine with quick clamp switch unlocked or without safety pin of moving hook can cause the bucket to drop off.**

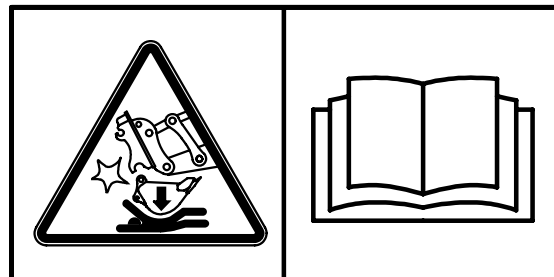

14070FW60

24) TIE (item 36)

This warning label is positioned on the lower frame.

- ⚠ **Never tow the machine using tie hole, because this may break.**
- ⚠ **See page 4-15 for detail.**

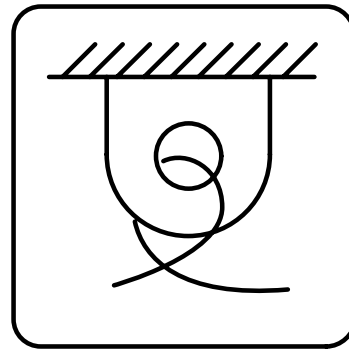

4507A0FW02

25) KEEP CLEAR-BOOM/ARM (item 37)

This warning label is positioned on both side of the arm.

- ⚠ **Serious injury or death can result from falling of the attachment.**
- ⚠ **To prevent serious injury or death, keep clear the underneath of attachment.**



14070FW31

26) ELECTRIC WELDING (item 38)

This warning label is positioned on the battery cover.

- ⚠ **Before carrying out any electric welding on this machine, follow the below procedure.**
  - Pull the connector out of all electric control units.
  - Connector the ground lead of the welding equipment as close to the welding point as possible.
- ※ **See page 6-47 for detail.**

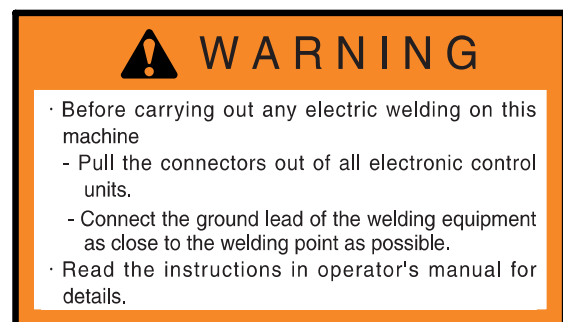

7807AFW20

## 27) FALLING (item 39)

This warning label is positioned on the top of the hydraulic tank.

- ▲ Falling is one of the major cause of personal injury.
- ▲ Be careful of slippery conditions on the platforms, steps and handrails when standing on the machine.

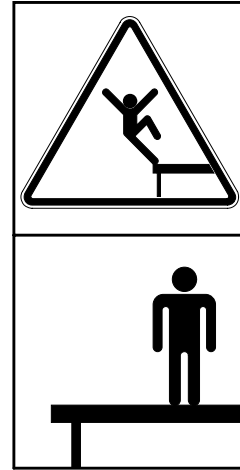

14070FW30

## 28) CAUTION (W/SEPARATOR, TURBOCHARGER) (item 41)

This warning label is positioned on the right window of the cab.

- ▲ In order to protect high pressure fuel system, please drain water in water separator before starting the engine.
- ▲ In order to prevent turbocharger failure, please allow more than 5 minutes' cool down period (no load low idle operation) before shutting the engine off.

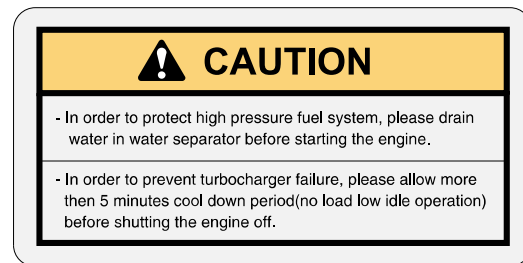

120090SL02

## 29) REFLECTING (item 42)

This warning label is positioned on the rear of counterweight.

- ▲ To prevent serious personal injury or death keep clear of machine swing radius.
- ▲ Do not deface or remove this label from the machine.

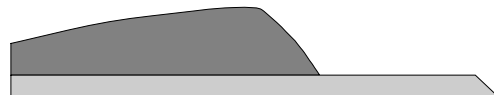

21090FW70



### 30) ACCUMULATOR (item 43)

This warning label is positioned on the accumulator of the solenoid valve.

- ※ The accumulator is filled with high-pressure nitrogen gas, and it is extremely dangerous if it is handled in the wrong way. Always observe the following precautions.
- ▲ Never make any hole in the accumulator expose it to flame or fire.
- ▲ Do not weld anything to the accumulator.
- ※ When carrying out disassembly or maintenance of the accumulator, or when disposing of the accumulator, it is necessary to release the gas from the accumulator. A special air bleed valve is necessary for this operation, so please contact your Hyundai distributor.

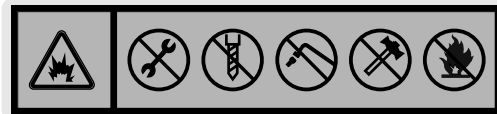

1107A0FW46

### 31) MACHINE CONTROL PATTERN-CAB (item 44)

This warning label is positioned on the right side window of the cab.

- ▲ The machine control pattern can easily be changed to the "ISO type" or to the "A type" by changing the position of the lever of the pattern change valve.
- ▲ Before starting this machine, check the lever pattern valve.
- ※ See page 4-27 for detail.

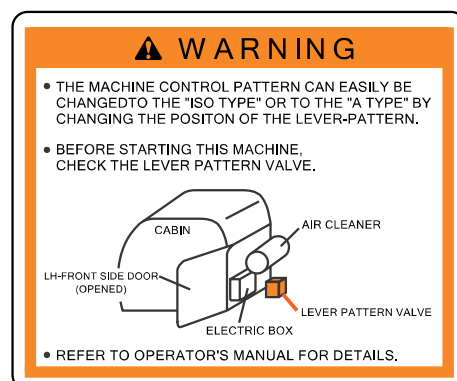

2609A0SL11

### 32) RCV LEVER PATTERN (item 45)

This warning label is positioned on the LH mid screen plate.

- ▲ Check the machine control pattern for conformance to pattern on this label. If not, change label to match pattern before operating machine.
- ▲ Failure to do so could result in injury or death.
- ※ See page 4-26 for details.

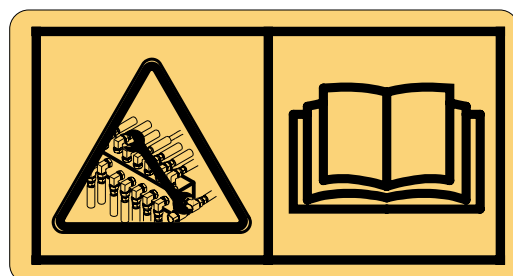

14W90FW47

### 33) MACHINE CONTROL PATTERN (item 46)

This warning label is positioned on the LH mid screen plate.

**⚠ Check the machine control pattern for conformance to pattern on this label. If not, change label to match pattern before operating machine.**

**⚠ Failure to do so could result in injury or death.**

※ See page 4-27 for details.

**⚠ WARNING**

- THE MACHINE CONTROL PATTERN CAN EASILY BE CHANGED TO THE "ISO TYPE" "OR TO THE "A TYPE" BY CHANGING THE POSITION OF THE LEVER-PATTERN.
- BEFORE STARTING THIS MACHINE, CHECK THE LEVER PATTERN VALVE.

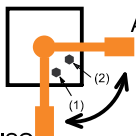



**ISO**

- HOW TO USE:
  1. LOOSEN BOLT(1) OR BOLT(2).
  2. MOVE LEVER TO THE "ISO" OR "A" POSITION.
  3. AFTER SETTING THE PATTERN, TIGHTEN BOLT TO SECURE LEVER.
- BOLT(1) FOR "ISO" PATTERN
- BOLT(2) FOR "A" PATTERN

• REFER TO OPERATOR'S MANUAL FOR DETAILS.

**ISO TYPE**

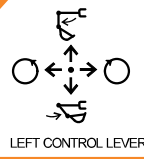

POSITION OF LEVER-PATTERN:



LEFT CONTROL LEVER    RIGHT CONTROL LEVER

**A TYPE**

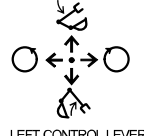
POSITION OF LEVER-PATTERN:



LEFT CONTROL LEVER    RIGHT CONTROL LEVER

38090FW01A

### 34) SWING BEARING GREASE (item 47)

This warning label is positioned in the front of swing ring gear.

※ See page 6-38 for details.

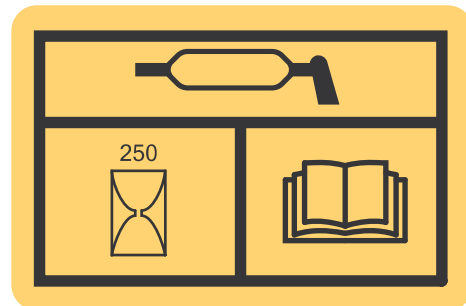

38090FW04

### 35) BATTERY POSITION (item 48)

This warning label is positioned right side of tool box.

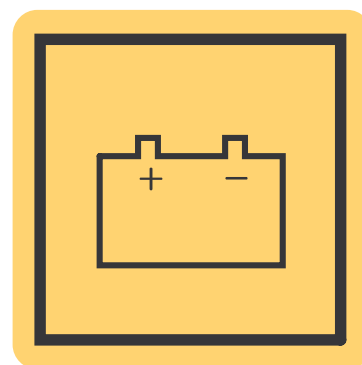

38090FW03

### 36) BEACON LAMP (item 49)

This warning label is positioned on the right outside of the cabin.

- ※ **Make sure the beacon lamp maintains a vertical position.**

A horizontal position can result in a decrease in life time of the lamp due to the infiltration of foreign substances such as dust or water.

- ※ **While the machine transfer, the beacon lamp is easy to break. In that case, change the position of the lamp to the horizontal.**

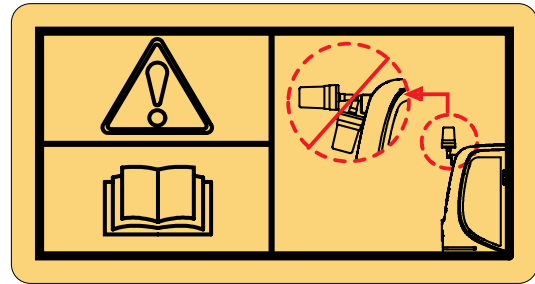

140Z90FW49

### 37) FUEL SHUT OFF (item 50)

This warning label is positioned on the left side of the hydraulic tank.

- ※ **Fill only the hydraulic oil.**
- ※ **Do not fill the diesel fuel.**

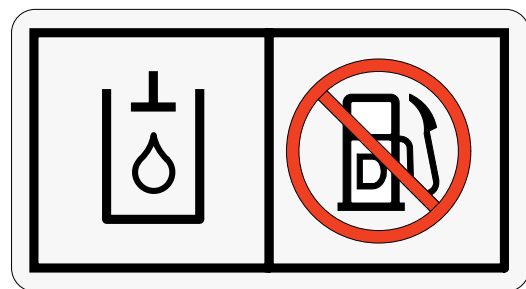

140WH90FW51

### 38) MCU/ECM CONNECTOR (item 51)

This warning label is positioned on the low cover of the air conditioner in the cab.

- ※ **MCU communicates the machine data with Laptop computer through RS232 service socket.**
- ※ **ECM communicates the engine data with cummins INSITE tool adapter through J1939 service socket.**
- ※ **See page 3-60 for details.**

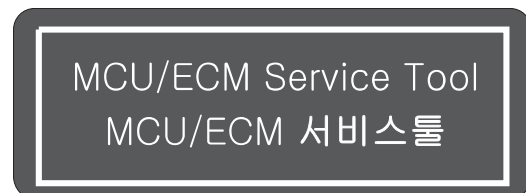

235Z90FW52

### 39) ULTRA LOW SULFUR DIESEL (item 52)

This warning label is positioned on the light side of fuel filler neck.

- ※ **Use ultra low sulfur fuel only.**
- ※ **Ultra low sulfur diesel sulfur content  $\leq$  15 ppm**

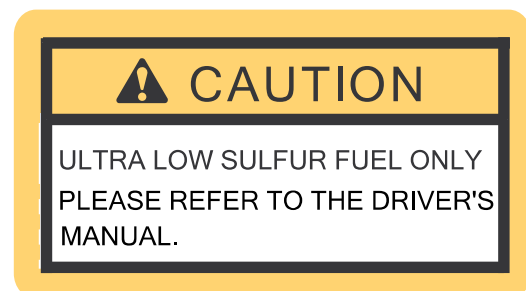

2609A0SL03

#### 40) LUBRICATION OIL (item 54)

This warning label is positioned on the right side of side cover.

- ※ **Recommended lub oil ACEA-E9 is equivalent to CJ-4.**

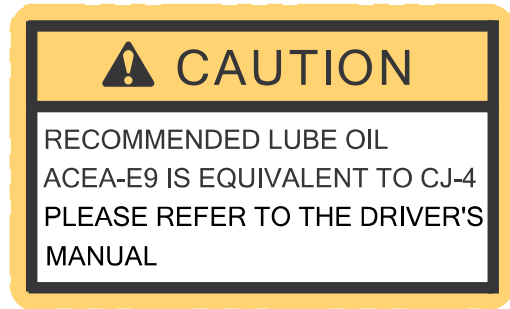

145Z9A0SL04

#### 41) SURGE TANK (item 55)

This warning label is positioned on the top of the surge tank.

This system must be filled slowly to prevent air locks.

- ※ **Fill rate  $\leq$  11 lpm**

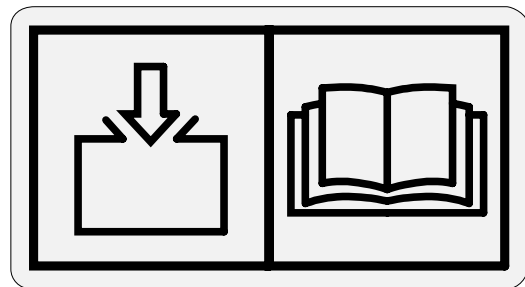

3009A0FW54

# MACHINE DATA PLATE

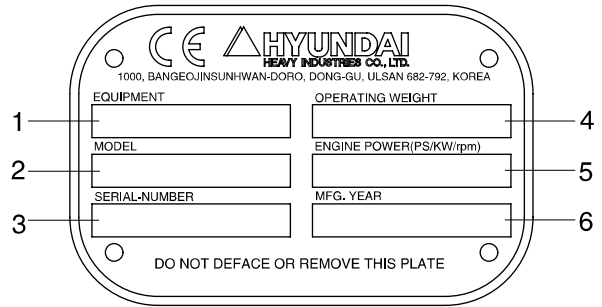
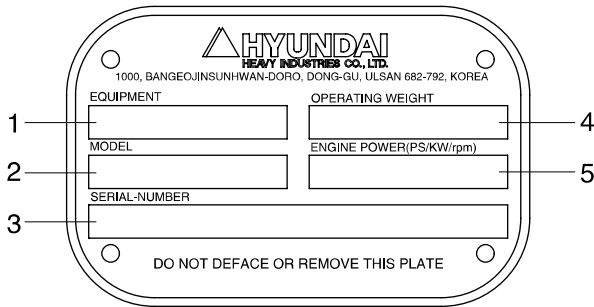

FOR EU ONLY

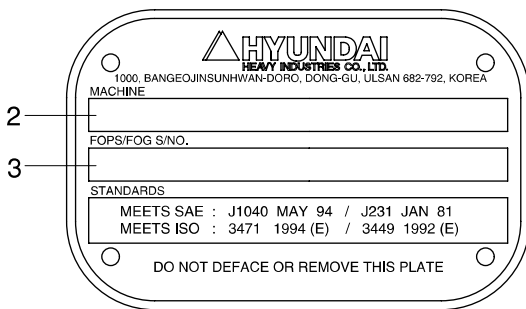

FOR FOPS/FOG

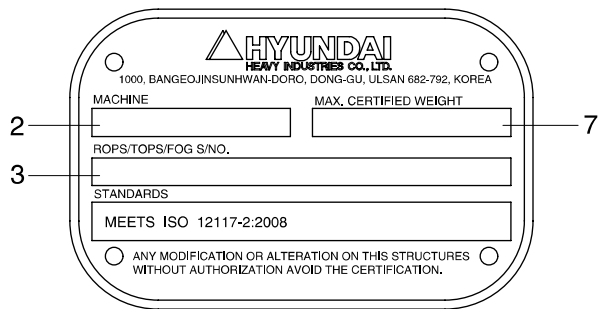

ROPS

2609A0FW01

- |   |                          |   |              |   |                    |
|---|--------------------------|---|--------------|---|--------------------|
| 1 | Equipment                | 2 | Model name   | 3 | Serial number      |
| 4 | Operating weight         | 5 | Engine power | 6 | Manufacturing year |
| 7 | Maximum certified weight |   |              |   |                    |

※ The machine serial number assigned to this particular machine and should be used when requesting information or ordering service parts for this machine from your authorized HYUNDAI dealer. The machine serial number is also stamped on the frame.

## GUIDE

### 1. DIRECTION

The direction of this manual indicate forward, backward, right and left on the standard of operator when the travel motor is in the rear and machine is on the traveling direction.

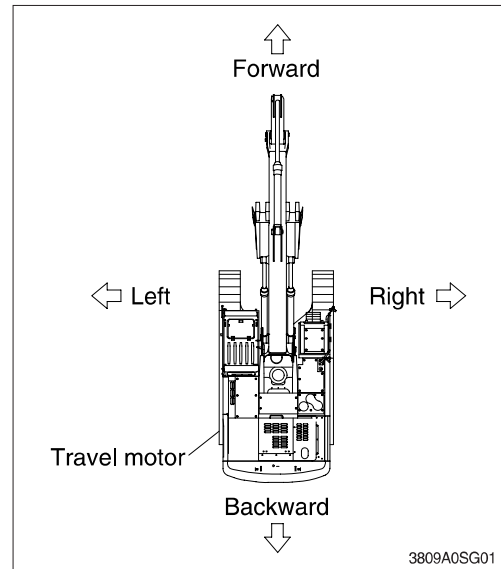

### 2. SERIAL NUMBER

Inform following when you order parts or the machine is out of order.

#### 1) MACHINE SERIAL NUMBER

The numbers are located below the right window of the operator's cab.

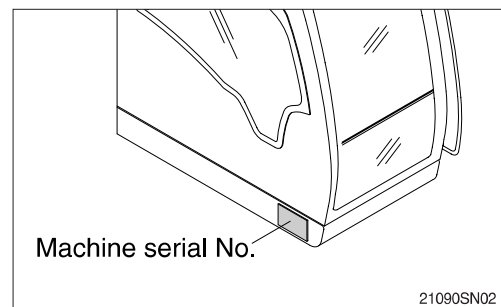

#### 2) ENGINE SERIAL NUMBER

The numbers are located on the engine name plate.

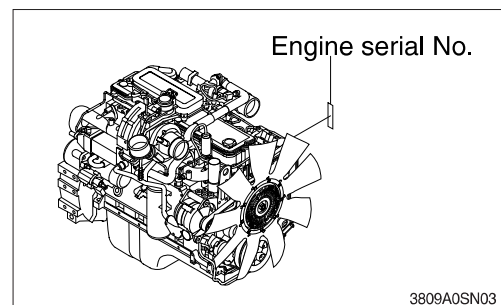

### 3. INTENDED USE

This machine is designed to be used mainly for the following work.

- Digging work
- Loading work
- Smoothing work
- Ditching work

※ Please refer to the section 4 (efficient working method) further details.

### 4. SYMBOLS

▲ Important safety hint.

△ It indicates matters which can cause the great loss on the machine or the surroundings.

※ It indicates the useful information for operator.

# SAFETY HINTS

## 1. BEFORE OPERATING THE MACHINE

Think-safety first.

In special situation, wear protective clothing including a safety helmet, safety shoes, gloves, safety glasses and ear protection as required by the job condition.

Almost every accident is caused by disregarding the simple and fundamental safety hints.

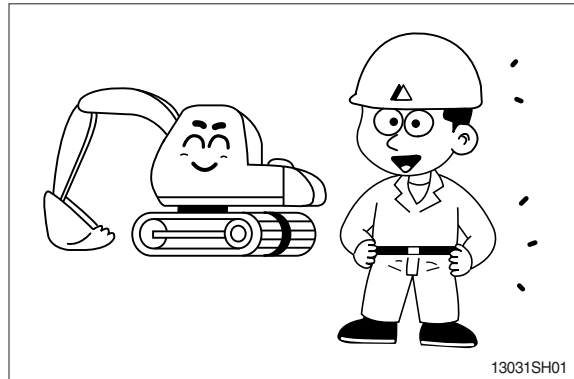

Be sure to understand thoroughly all about the operator's manual before operating the machine.

Proper care is your responsibility.

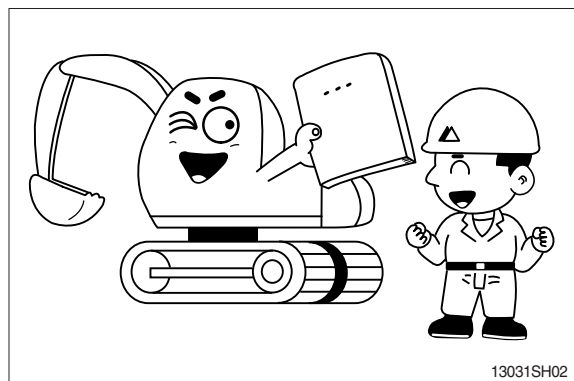

Fully understand the details and process of the construction before starting the work.

If you find anything dangerous on the job, consult with the job supervisor for the preventive measures before operating the machine.

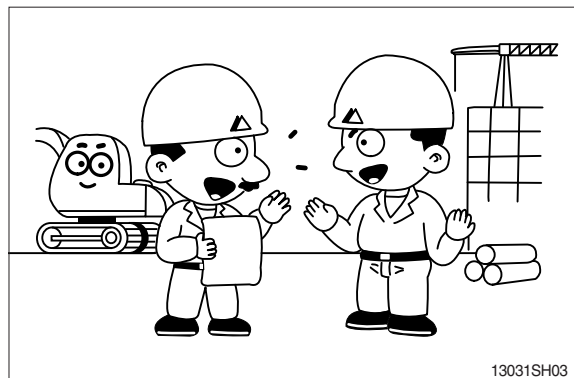

Do not operate when tired, or after drinking alcoholic beverages or any type of drugs.

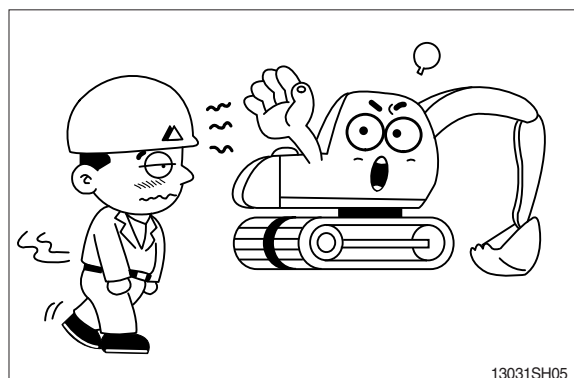

Check daily according to the operation manual.  
Repair the damaged parts and tighten the loosened bolts.

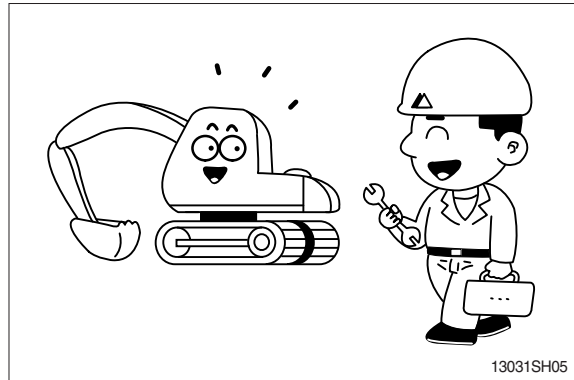

Check for leakage of engine oil, hydraulic oil, fuel and coolant.  
Keep machine clean, clean machine regularly.

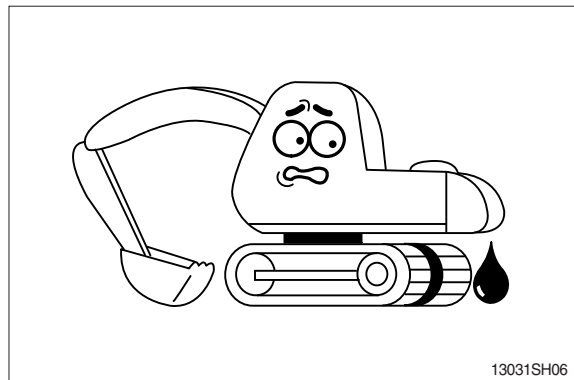

Do not operate the machine if it requires repairs.  
Operate after complete repair.

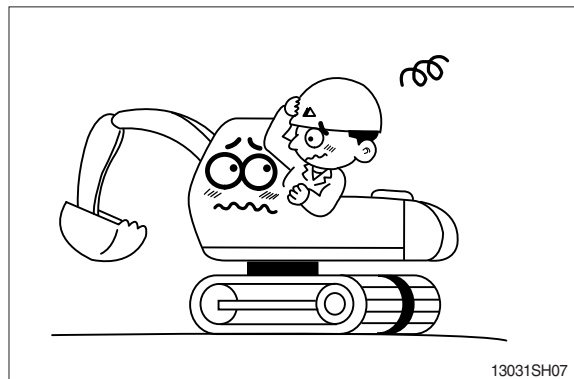

Be prepared if a fire starts.  
Keep a fire extinguisher handy and emergency numbers for a fire department near your telephone.

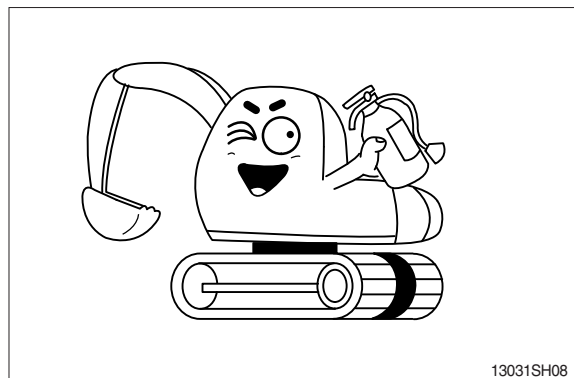



## PROTECTION AGAINST FALLING OR FLYING OBJECTS

If there is any danger of falling or flying objects hitting the operator, install protective guards in place to protect the operator as required for each particular situation.

Be sure to close the front window before commencing work.

Make sure to keep all persons other than operator outside the range of falling or flying objects. In case you need top guard, front guard and FOPS (falling object protective structure), please contact Hyundai distributor in Europe.

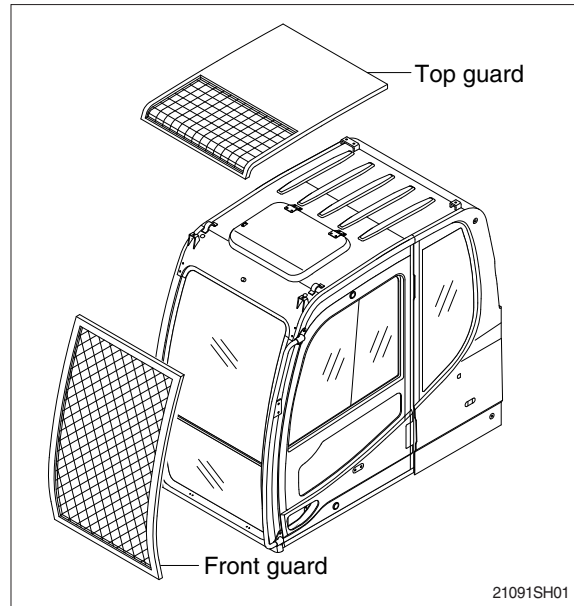

## UNAUTHORIZED MODIFICATION

Any modification made without authorization from Hyundai can create hazards.

Before making a modification, consult your Hyundai distributor. Hyundai will not be responsible for any injury or damage caused by any unauthorized modification.

## PREPARE FOR EMERGENCY

Only in case of emergency, use the installed hammer for breaking the windshield of the cab, and then exit carefully.

Be sure you know the phone numbers of persons you should contact in case of an emergency.

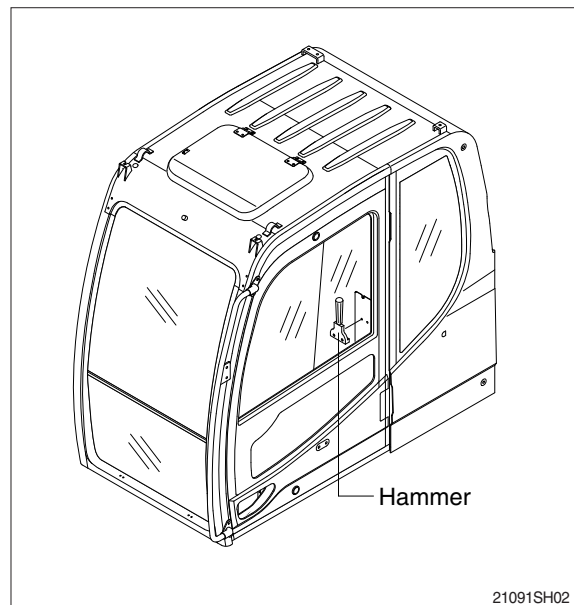

## ROTATING BEACON

When you operate a machine on a road or beside a road, a rotating beacon is required to avoid any traffic accident.

Please contact your Hyundai distributor to install it.

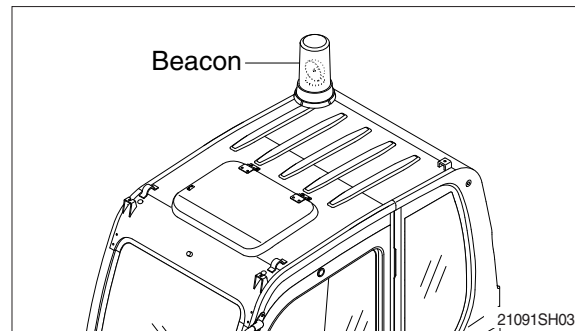

## PRECAUTIONS FOR ATTACHMENTS

When installing and using an optional attachment, read the instruction manual for the attachment and the information related to attachments in this manual.

Do not use attachments that are not authorized by Hyundai or your Hyundai distributor. Use of unauthorized attachments could create a safety problem and adversely affect the proper operation and useful life of the machine.

Any injuries, accidents, product failures resulting from the use of unauthorized attachments are not the responsibility of Hyundai.

The stability of this machine is enough to be used for general work. When you operate this machine, allow for the lifting capacity tables. If you want to use other special applications (not covered in this manual), you have to attach additional counterweight or be cautious while running the machine.

## SAFETY RULES

**Only** trained and authorized personnel can operate and maintain the machine.

Follow all safety rules, precautions and instructions when operating or performing maintenance on the machine.

When working with another operator or a person on worksite traffic duty, be sure all personnel understand all hand signals that are to be used.

## SAFETY FEATURES

Be sure all guards and covers are in their proper position. Have guards and covers repaired if damaged.

Use safety features such as safety lock and seat belts properly.

**Never** remove any safety features. **Always** keep them in good operating condition.

Improper use of safety features could result in serious bodily injury or death.

## MACHINE CONTROL PATTERN

Check machine control pattern for conformance to pattern on label in cab.

If not, change label to match pattern before operating machine.

Failure to do so could result in injury.

## CALIFORNIA PROPOSITION 65

Diesel engine exhaust and some of its constituents are known to the State of California to cause cancer, birth defects and other reproductive harm.

This product contains or emits chemicals known to the State of California to cause cancer or birth defects or other reproductive harm.

Battery posts, terminals and related accessories contain lead and lead compounds.

WASH HANDS AFTER HANDLING

Do not load the machine with the lifting eyes on the counterweight.

**▲ The wrong loading method can result in serious bodily injury or death.**

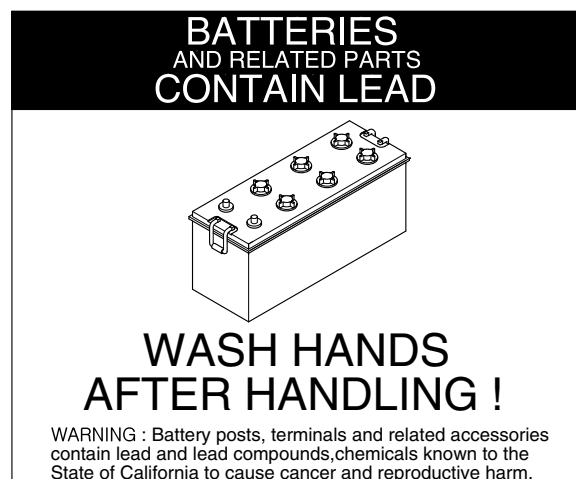

13031SH55

## FIRE PREVENTION AND EXPLOSION PREVENTION

### Regeneration

The exhaust gas temperatures during regeneration will be elevated. Follow proper fire prevention instructions and use the disable regeneration function when appropriate.

### General

All fuels, most lubricants, and some coolant mixtures are flammable.

To minimize the risk of fire or explosion, the following actions are recommended.

Always perform a Walk-Around Inspection, which may help you identify a fire hazard.

Do not operate a machine when a fire hazard exists. Contact your dealer for service.



3001SH01

Understand the use of the primary exit and alternative exit on the machine.

Do not operate a machine with a fluid leak. Repair leaks and clean up fluids before resuming machine operation. Fluids that are leaking or spilled onto hot surfaces or onto electrical components can cause a fire. A fire may cause personal injury or death.

Do not weld on or drill holes in the engine cover. Flammable material such as leaves, twigs, papers, trash may accumulate in engine compartment.

Remove flammable material such as leaves, twigs, papers, trash and so on. These items may accumulate in the engine compartment or around other hot areas and hot parts on the machine.

Keep the access doors to major machine compartments closed and access doors in working condition in order to permit the use of fire suppression equipment, in case a fire should occur.

Clean all accumulations of flammable materials such as fuel, oil, and debris from the machine.

Do not operate the machine near any flame.

Keep shields in place. Exhaust shields (if equipped) protect hot exhaust components from oil spray or fuel spray in a break in a line, in a hose, or in a seal. Exhaust shields must be installed correctly.

Do not weld or flame cut on tanks or lines that contain flammable fluids or flammable material. Empty and purge the lines and tanks. Then clean the lines and tanks with a nonflammable solvent prior to welding or flame cutting. Ensure that the components are properly grounded in order to avoid unwanted arcs.

Dust that is generated from repairing nonmetallic hoods or fenders may be flammable and/or explosive. Repair such components in a ventilated area away from open flames or sparks. Use suitable Personal Protection Equipment (PPE).

Inspect all lines and hoses for wear or deterioration. Replace damaged lines and hoses. The lines and the hoses should have adequate support and secure clamps. Tighten all connections to the recommended torque. Damage to the protective cover or insulation may provide fuel for fires.

## SAFETY FEATURES

Be sure all guards and covers are in their proper position. Have guards and covers repaired if damaged.

Use safety features such as safety lock and seat belts properly.

**Never** remove any safety features. **Always** keep them in good operating condition.

Improper use of safety features could result in serious bodily injury or death.

## MACHINE CONTROL PATTERN

Check machine control pattern for conformance to pattern on label in cab.

If not, change label to match pattern before operating machine.

Failure to do so could result in injury.

## CALIFORNIA PROPOSITION 65

Diesel engine exhaust and some of its constituents are known to the State of California to cause cancer, birth defects and other reproductive harm.

This product contains or emits chemicals known to the State of California to cause cancer or birth defects or other reproductive harm.

Battery posts, terminals and related accessories contain lead and lead compounds.

WASH HANDS AFTER HANDLING

Do not load the machine with the lifting eyes on the counterweight.

**▲ The wrong loading method can result in serious bodily injury or death.**

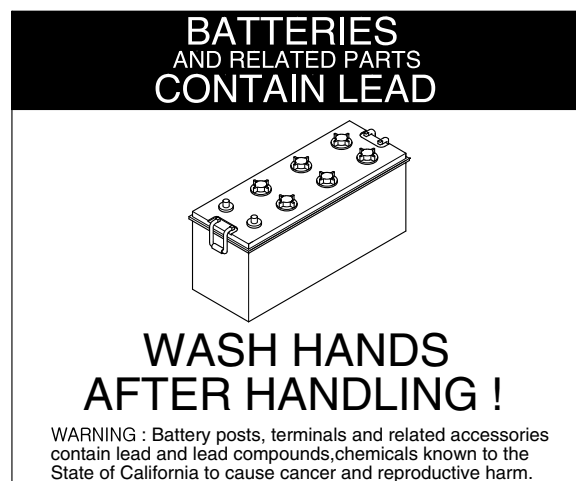

13031SH55

Store fuels and lubricants in properly marked containers away from unauthorized personnel. Store oily rags and flammable materials in protective containers. Do not smoke in areas that are used for storing flammable materials.



3001SH02

Use caution when you are fueling a machine. Do not smoke while you are fueling a machine. Do not fuel a machine near open flames or sparks. Always stop the engine before fueling. Fill the fuel tank outdoors. Properly clean areas of spillage.



Never store flammable fluids in the operator compartment of the machine.

3001SH03

### Battery and battery cables

The following actions are recommended to minimize the risk of fire or an explosion related to the battery.



3001SH04

Do not operate a machine if battery cables or related parts show signs of wear or damage. Contact your dealer for service.

Follow safe procedures for engine starting with jump-start cables. Improper jumper cable connections can cause an explosion that may result in injury.

Do not charge a frozen battery. This action may cause an explosion.

Gases from a battery can explode. Keep any open flames or sparks away from the top of a battery. Do not smoke in battery charging areas.

Never check the battery charge by placing a metal object across the terminal posts. Use a voltmeter in order to check the battery charge.

Daily inspect battery cables that are in areas that are visible. Inspect cables, clips, straps, and other restraint for damage. Replace any damaged parts. Check for signs of the following, which can occur over time due to use and environmental factors :

- Fraying
- Abrasion
- Cracking
- Discoloration
- Cuts on the insulation of the cable
- Fouling
- Corroded terminals, damaged terminals, and loose terminals

Replace damaged battery cable (s) and replace any related parts. Eliminate any fouling, which may have caused insulation failure or related component damage or wear. Ensure that all components are reinstalled correctly.

An exposed wire on the battery cable may cause a short ground if the exposed area comes into contact with a grounded surface. A battery cable short produces heat from the battery current, which may be a fire hazard.

An exposed wire on the ground cable between the battery and the disconnect switch may cause the disconnect switch to be bypassed if the exposed area comes into contact with a grounded surface. This action may result in an unsafe condition for servicing the machine. Repair components or replace components before servicing the machine.

**▲ Fire on a machine can result in personal injury or death. Exposed battery cables that come into contact with a grounded connection can result in fires. Replace cables and related parts that show signs of wear or damage. Contact your Hyundai Heavy Industries dealer.**

## **Wiring**

Check electrical wires daily. If any of the following conditions exist, replace parts before you operate the machine.

- Fraying
- Signs of abrasion or wear
- Cracking
- Discoloration
- Cuts on insulation
- Other damage

Make sure that all clamps, guards, clips, and straps are reinstalled correctly. This action will help to prevent vibration, rubbing against other parts, and excessive heat during machine operation.

Attaching electrical wiring to hoses and tubes that contain flammable fluids or combustible fluids should be avoided.

Consult your Hyundai Heavy Industries dealer for repair or for replacement parts.

Keep wiring and electrical connections free of debris.

## **Lines, Tubes, and Hoses**

Do not bend high-pressure lines. Do not strike high-pressure lines. Do not install any lines that are bent or damaged. Use the appropriate backup wrenches in order to tighten all connections to the recommended torque.

Check lines, tubes, and hoses carefully. Wear Personal Protection Equipment (PPE) in order to check for leaks. Always use a board or cardboard when you check for a leak. Leaking fluid that is under pressure can penetrate body tissue. Fluid penetration can cause serious injury and possible death. A pin hole leak can cause severe injury. If fluid is injected into your skin, you must get treatment immediately. Seek treatment from a doctor that is familiar with this type of injury.

Replace the affected parts if any of the following conditions are present :

- End fittings are damaged or leaking.
- Outer coverings are chafed or cut.
- Wires are exposed.
- Outer coverings are swelling or ballooning.
- Flexible parts of the hoses are kinked.
- Outer covers have exposed embedded armoring.
- End fittings are displaced.

Make sure that all clamps, guards, and heat shields are installed correctly. During machine operation, this action will help to prevent vibration, rubbing against other parts, excessive heat, and failure of lines, tubes, and hoses.

Do not operate a machine when a fire hazard exists. Repair any lines that are corroded, loose, or damaged. Leaks may provide fuel for fires. Consult your Hyundai Heavy Industries dealer for repair or for replacement parts.

## **Ether**

Ether (if equipped) is commonly used in cold weather applications. Ether is flammable and poisonous.

Do not spray ether manually into an engine if the machine is equipped with a thermal starting aid for cold weather starting.

Use ether in ventilated areas. Do not smoke while you are replacing an ether cylinder or while you are using an ether spray.

Do not store ether cylinders in living areas or in the operator compartment of a machine. Do not store ether cylinders in direct sunlight or in temperatures above 49°C(120.2 °F). Keep ether cylinders away from unauthorized personnel.



## Fire Extinguisher

As an additional safety measure, keep a fire extinguisher on the machine.

Be familiar with the operation of the fire extinguisher. Inspect the fire extinguisher and service the fire extinguisher regularly. Follow the recommendations on the instruction plate.

Consider installation of an aftermarket Fire Suppression System, if the application and working conditions warrant the installation.

## Fire Safety

※ **Locate secondary exits and how to use the secondary exits before you operate the machine.**

※ **Locate fire extinguishers and how to use a fire extinguisher before you operate the machine.**

If you find that you are involved in a machine fire, your safety and that of others on site is the top priority. The following actions should only be performed if the actions do not present a danger or risk to you and any nearby people. At all times you should assess the risk of personal injury and move away to a safe distance as soon as you feel unsafe.

Move the machine away from nearby combustible material such as fuel/oil stations, structures, trash, mulch and timber.

Lower any implements and turn off the engine as soon as possible. If you leave the engine running, the engine will continue to feed a fire. The fire will be fed from away damaged hoses that are attached to the engine or pumps.

If possible, turn the battery disconnect switch to the OFF position. Disconnecting the battery will remove the ignition source in the event of an electrical short. Disconnecting the battery will eliminate a second ignition source if electrical wiring is damaged by the fire, resulting in a short circuit.

Notify emergency personnel of the fire and your location.

If your machine is equipped with a fire suppression system, follow the manufacturers procedure for activating the system.

※ **Fire suppression systems need to be regularly inspected by qualified personnel. You must be trained to operate the fire suppression system.**

Use the on-board fire extinguisher and use the following procedure :

1. Pull the pin.
2. Aim the extinguisher or nozzle at the base of the fire.
3. Squeeze the handle and release the extinguishing agent.
4. Sweep the extinguisher from side to side across the base of the fire until the fire is out.

Remember, if you are unable to do anything else, shut off the machine before exiting. By shutting off the machine, fuels will not continue to be pumped into the fire.

If the fire grows out of control, be aware of the following risks :

- Tires on wheeled machines pose a risk of explosion as tires burn. Hot shrapnel and debris can be thrown great distances in an explosion.
- Tanks, accumulators, hoses, and fittings can rupture in a fire, spraying fuels and shrapnel over a large area.

Remember that nearby all of the fluids on the machine are flammable, including coolant and oils. Additionally, plastics, rubbers, fabrics, and resins in fiberglass panels are also flammable.

## **Fire extinguisher Location**

Make sure that a fire extinguisher is available. Be familiar with the operation of the fire extinguisher. Inspect the fire extinguisher and service the fire extinguisher. Obey the recommendations on the instruction plate.

Mount the fire extinguisher in the accepted location per local regulations.

If your machine is equipped with a ROPS structure, strap the mounting plate to the ROPS in order to mount the fire extinguisher. If the weight of the fire extinguisher exceeds 4.5 kg (10 lb), mount the fire extinguisher near the bottom of the ROPS. Do not mount the fire extinguisher at the upper one-third area on the ROPS.

Do not weld the ROPS structure in order to install the fire extinguisher. Also, do not drill holes in the ROPS structure in order to mount the fire extinguisher on the ROPS.

Consult your Hyundai Heavy Industries dealer for the proper procedure for mounting the fire extinguisher.

## THE EUROPEAN UNION PHYSICAL AGENTS (VIBRATION) DIRECTIVE 2002/44/EC

### Vibration Data for Earth-moving Machines

#### Information Concerning Hand/Arm Vibration Level

When the machine is operated according to the intended use, the hand/arm vibration of this machine is below 2.5 m/s<sup>2</sup>.

#### Information Concerning Whole Body Vibration Level

The highest root mean square value of weighted acceleration to which the whole body is subjected, is less than 0.5 m/s<sup>2</sup>.

This section provides vibration data and a method for estimating the vibration level for earth moving machines.

**Vibration levels are influenced by many different parameters. Many items are listed below.**

- Operator training, behavior, mode and stress
- Job site organization, preparation, environment, weather and material
- Machine type, quality of the seat, quality of the suspension system, attachments and condition of the equipment

It is not possible to get precise vibration levels for this machine. The expected vibration levels can be estimated with the information in below Table in order to calculate the daily vibration exposure. A simple evaluation of the machine application can be used.

Estimate the vibration levels for the three vibration directions. For typical operating conditions, use the average vibration levels as the estimated level. With an experienced operator and smooth terrain, subtract the Scenario Factors from the average vibration level. For aggressive operations and severe terrain, add the Scenario Factors to the average vibration level in order to obtain the estimated vibration level.

※ All vibration levels are in meter per second squared.

ISO Reference Table A – Equivalent vibration levels of whole body vibration emission for earthmoving equipment.

Machine family	Machine kind	Typical operating condition	Vibration Levels			Scenario Factors		
			X axis	Y axis	Z axis	X axis	Y axis	Z axis
Excavator	Compact crawler excavator	Excavating	0.33	0.21	0.19	0.19	0.12	0.10
		Hydraulic breaker app.	0.49	0.28	0.36	0.20	0.13	0.17
		Transfer movement	0.45	0.39	0.62	0.17	0.18	0.28
	Crawler excavator	Excavating	0.44	0.27	0.30	0.24	0.16	0.17
		Hydraulic breaker app.	0.53	0.31	0.55	0.30	0.18	0.28
		Mining application	0.65	0.42	0.61	0.21	0.15	0.32
		Transfer movement	0.48	0.32	0.79	0.19	0.20	0.23
	Wheeled excavator	Excavating	0.52	0.35	0.29	0.26	0.22	0.13
Transfer movement		0.41	0.53	0.61	0.12	0.20	0.19	

ISO Reference Table A – Equivalent vibration levels of whole body vibration emission for earthmoving equipment.

Machine family	Machine kind	Typical operating condition	Vibration Levels			Scenario Factors		
			X axis	Y axis	Z axis	X axis	Y axis	Z axis
Loader	skid steer loader (tracks)	V-shaped motion	1.21	1.00	0.82	0.30	0.84	0.32
	Wheel backhoe loader	Excavating	0.28	0.26	0.20	0.09	0.16	0.06
	Wheel loader	Load and carry motion	0.84	0.81	0.52	0.23	0.20	0.14
		Mining application	1.27	0.97	0.81	0.47	0.31	0.47
		Transfer movement	0.76	0.91	0.49	0.33	0.35	0.17
		V-shape motion	0.99	0.84	0.54	0.29	0.32	0.14

※ Refer to “ISO/TR 25398 Mechanical Vibration-Guideline for the assessment of exposure to whole body vibration of ride on operated earthmoving machines” for more information about vibration. This publication uses data that is measured by international institutes, organizations and manufacturers. This document provides information about the whole body exposure of operators of earthmoving equipment.

## **Guidelines for Reducing Vibration Levels on Earthmoving Equipment**

Properly adjust machines. Properly maintain machines. Operate machines smoothly. Maintain the conditions of the terrain. The following guidelines can help reduce the whole body vibration level :

1. Use the right type and size of machine, equipment, and attachments.
2. Maintain machines according to the manufacturer's recommendations.
  - a. Tire pressures
  - b. Brake and steering systems
  - c. Controls, hydraulic system and linkages
3. Keep the terrain in good condition.
  - a. Remove any large rocks or obstacles.
  - b. Fill any ditches and holes.
  - c. Provide machines and schedule time in order to maintain the conditions of the terrain.
4. Use a seat that meets "ISO 7096". Keep the seat maintained and adjusted.
  - a. Adjust the seat and suspension for the weight and the size of the operator.
  - b. Inspect and maintain the seat suspension and adjustment mechanisms.
5. Perform the following operations smoothly.
  - a. Steer
  - b. Brake
  - c. Accelerate
  - d. Shift the gears.
6. Move the attachments smoothly.
7. Adjust the machine speed and the route in order to minimize the vibration level.
  - a. Drive around obstacles and rough terrain.
  - b. Slow down when it is necessary to go over rough terrain.
8. Minimize vibrations for a long work cycle or a long travel distance.
  - a. Use machines that are equipped with suspension systems.
  - b. Use the ride control system on machines.
  - c. If no ride control system is available, reduce speed in order to prevent bounce.
  - d. Haul the machines between workplaces.
9. Less operator comfort may be caused by other risk factors. The following guidelines can be effective in order to provide better operator comfort:
  - a. Adjust the seat and adjust the controls in order to achieve good posture.
  - b. Adjust the mirrors in order to minimize twisted posture.
  - c. Provide breaks in order to reduce long periods of sitting.
  - d. Avoid jumping from the cab
  - e. Minimize repeated handling of loads and lifting of loads.
  - f. Minimize any shocks and impacts during sports and leisure activities.

## **Sources**

The vibration information and calculation procedure is based on "ISO/TR 25398 Mechanical Vibration-Guideline for whole body vibration exposure of operators of earthmoving equipment. The method is based on measured vibration emission under real working conditions for all machines.

You should check the original directive. This document summarizes part of the content of the applicable law. This document is not meant to substitute the original sources. Other parts of these documents are based on information from the United Kingdom Health and Safety Executive.

## 2. DURING OPERATING THE MACHINE

Use the handle and footstep when getting on or off the machine.

Do not jump on or off the machine.

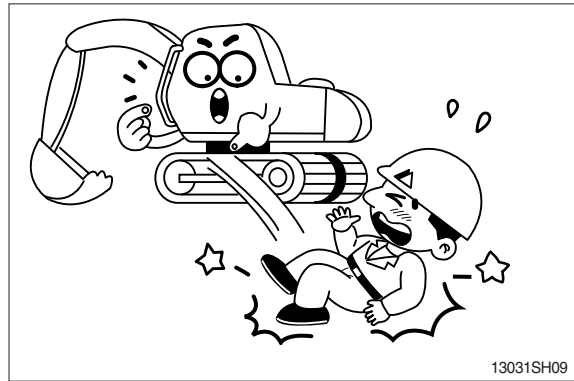

Sound the horn to warn nearby personnel before operating the machine.

Remove all the obstacles like frost on the window before operating the machine for the good visibility.

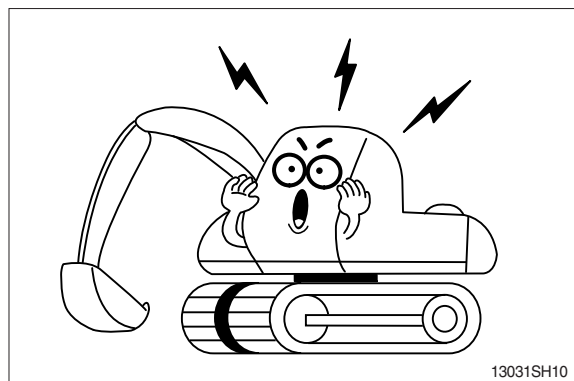

Operate carefully to make sure all personnel or obstacles are clear within the working range of the machine.

Place safety guards if necessary.

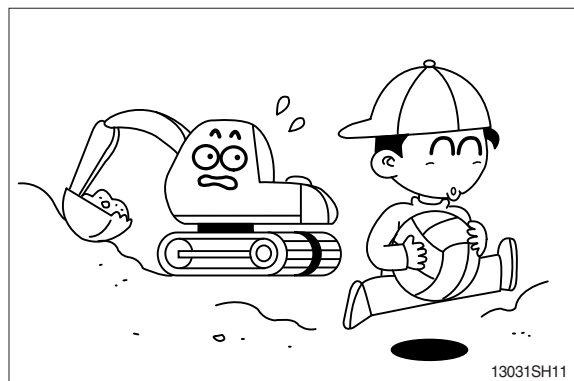

When using the work equipment, pay attention to job site.

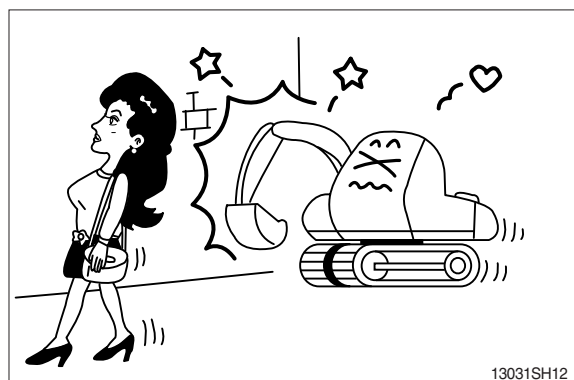

Provide proper ventilation when operating engine in a closed area to avoid the danger of exhaust gases.

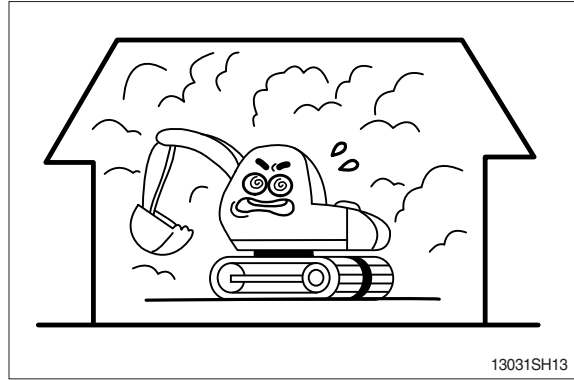

Check the locations of underground gas pipes or water line and secure the safety before operation.

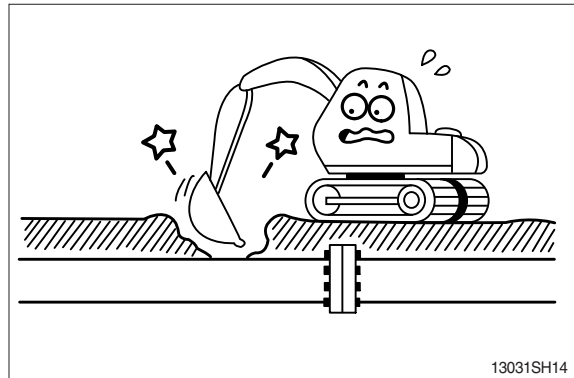

The operating near the electrical lines is very dangerous. Operate within safe working range permitted as below.

Supply voltage	Min safe separation
6.6 kV	3m (10 ft)
33.0 kV	4m (13 ft)
66.0 kV	5m (16 ft)
154.0 kV	8m (26 ft)
275.0 kV	10m (33 ft)

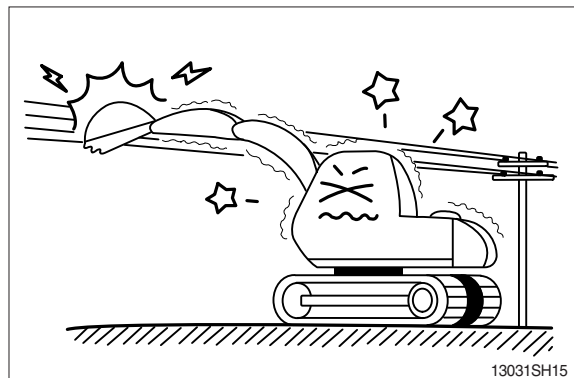

If the machine touches the electric power lines, keep sitting on the operator's seat and make sure the personnel on the ground not to touch the machine until turning off the electric current. Jump off the machine without contacting the machine when you need to get off.

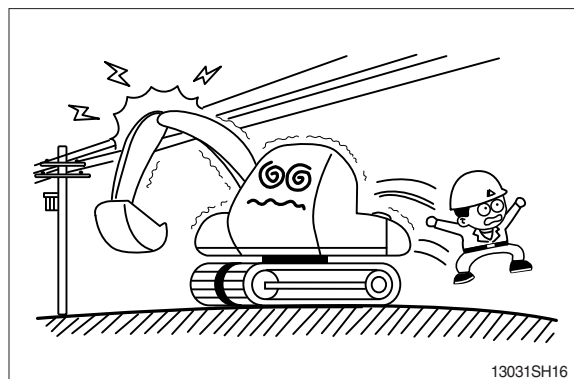

Watch out for obstacles.  
Be particularly careful to check the machine clearance during the swing.

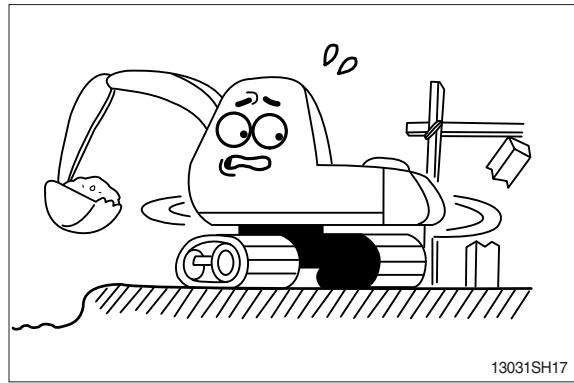

When using the machine as breaker or working in a place where stones may fall down, cab roof guard and head guard should be provided for proper protection.

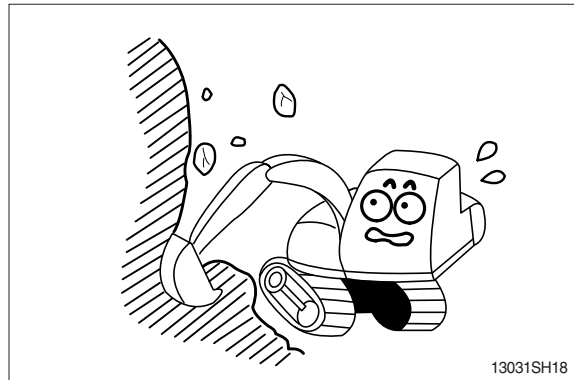

Avoid operating on a cliff or soft ground as there is danger of rolling over.  
Make sure to get off easily as keeping the track at a right angle and putting the travel motor into the backward position when working on a cliff or soft ground inevitably.

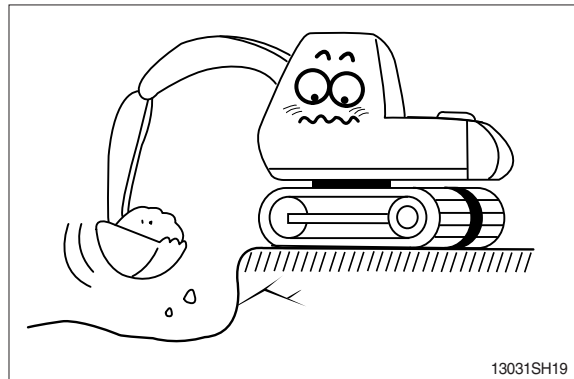

Operate for the lifting work considering the capacity of machine, weight and width of the load.  
Be careful not to lift exceeding the machine capacity as it can be the cause of machine damage and safety accident.

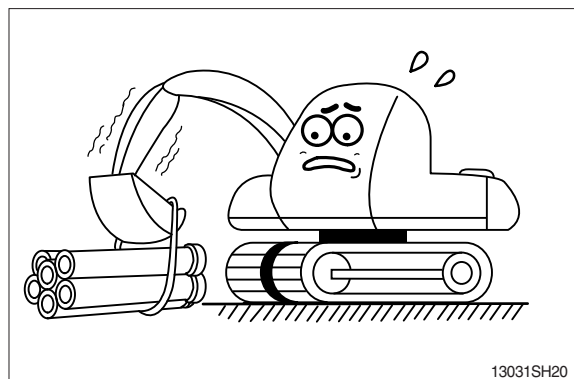



The operation on a slope is dangerous.  
Avoid operating the machine on a slope of over 10 degree.

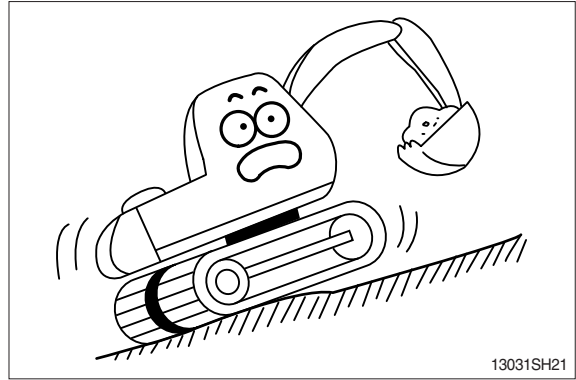

Operate the machine after making ground flat when operation is required on a slope.

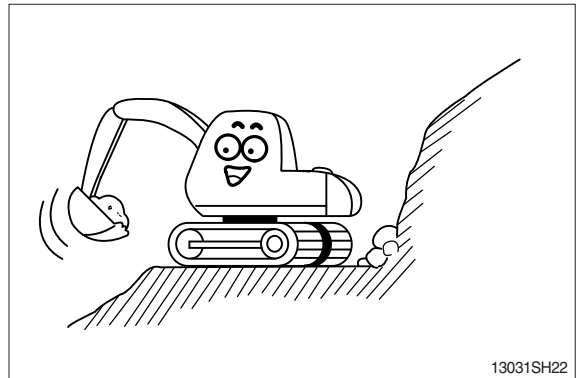

The swing on the slope can be danger of rolling over.  
Do not operate to swing the machine with the bucket loaded on a slope since the machine may lose its balance under such an instance.

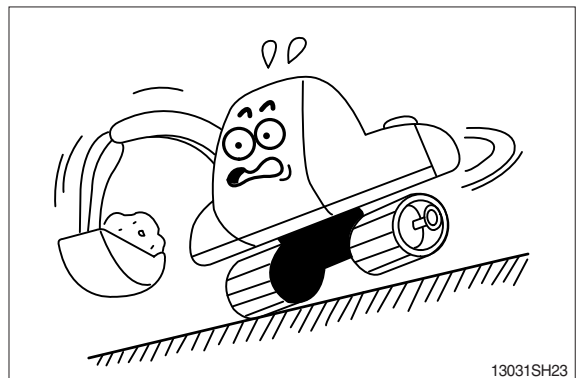

Avoid parking and stopping on a slope.  
Lower the bucket to the ground and block the track when parking.

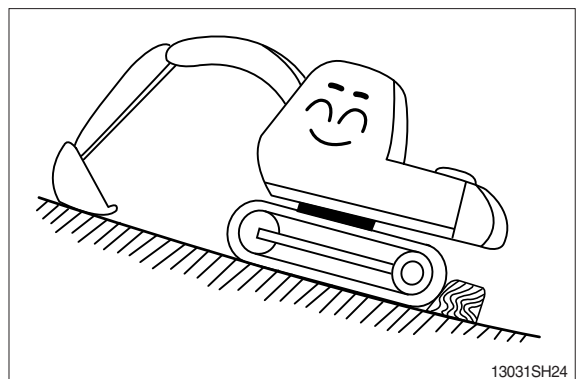

Avoid traveling in a cross direction on a slope as it can cause the danger of rolling over and sliding.

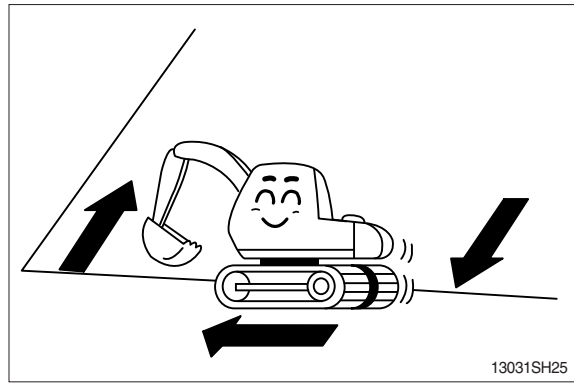

Traveling on a slope is dangerous. Be sure to operate slowly when traveling down a slope and maintain the bucket at a height of 20~30 cm (1 ft) above the ground so that it can be used as brake in an emergency.

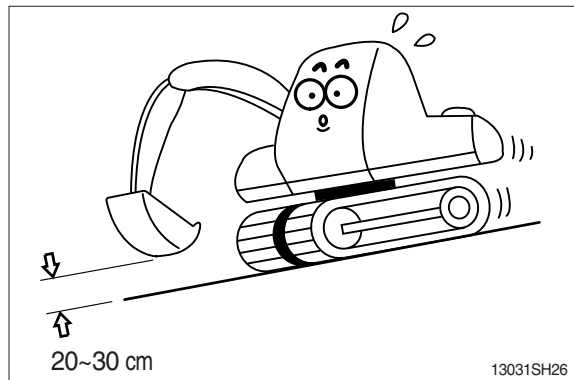

Steering of the machine while traveling on a slope is dangerous. When an inevitable turning of direction is required, turn on the flat and solid ground.

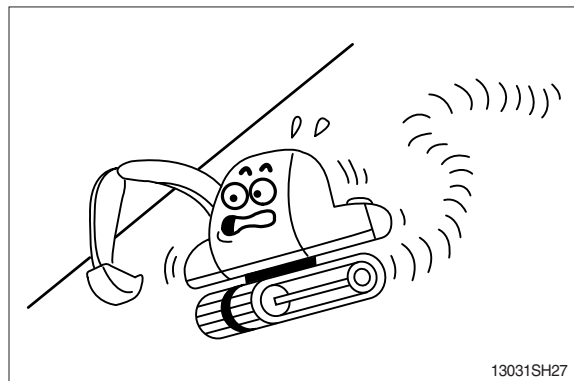

The engine angularity limits are 35 degree. Do not operate by more than the engine limits in any case.

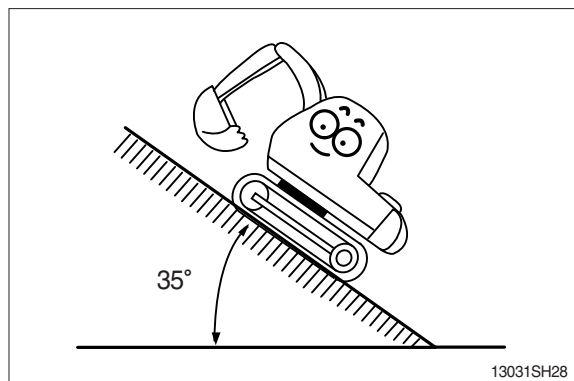

Before traveling the machine, sound the horn to warn nearby personnel.  
Operate forward and backward correctly with confirming the location of the travel motor.

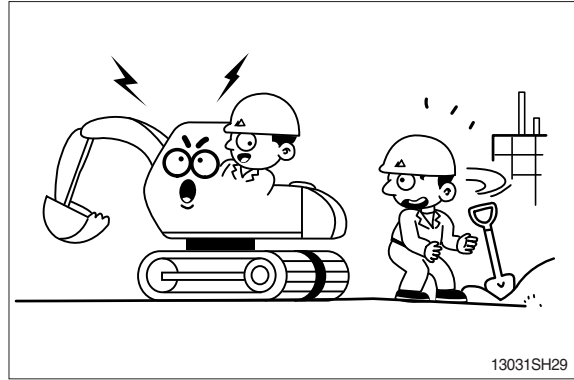

Slow down when traveling through obstacles or uneven ground.

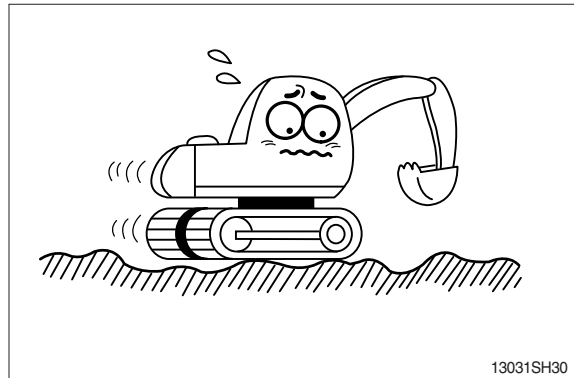

When working on soft ground, place mats or wood boards on the ground to prevent the machine sinking.

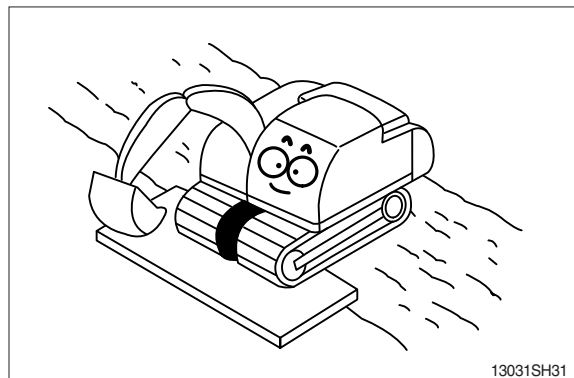

When operating in water or when crossing shallow, check the bed soil condition and depth and flow speed of water, then proceed taking care that water is not above carrier roller.

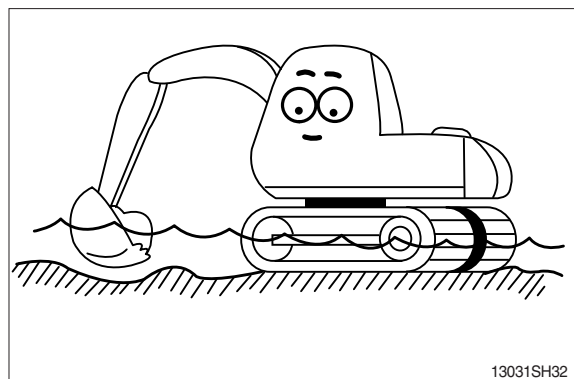

## MOUNTING AND DISMOUNTING

**Never** jump on or off the machine. **Never** get on or off a moving machine.

When mounting or dismounting, always face the machine and use the handrails, machine or track frame steps, and track shoes. Additional track frame step can be fitted for wider optional shoe. In this case please contact your Hyundai distributor.

Do not hold any control levers when getting on or off the machine.

Ensure safety by always maintaining at least three-point contact of hands and feet with the handrails, steps or track shoes.

Always remove any oil or mud from the handrails, steps and track shoes. If they are damaged, repair them and tighten any loose bolts.

If grasping the door handrail when mounting or dismounting or moving on the track, open and lock the door securely in the open position. Otherwise, the door may move suddenly, causing you to lose balance and fall.

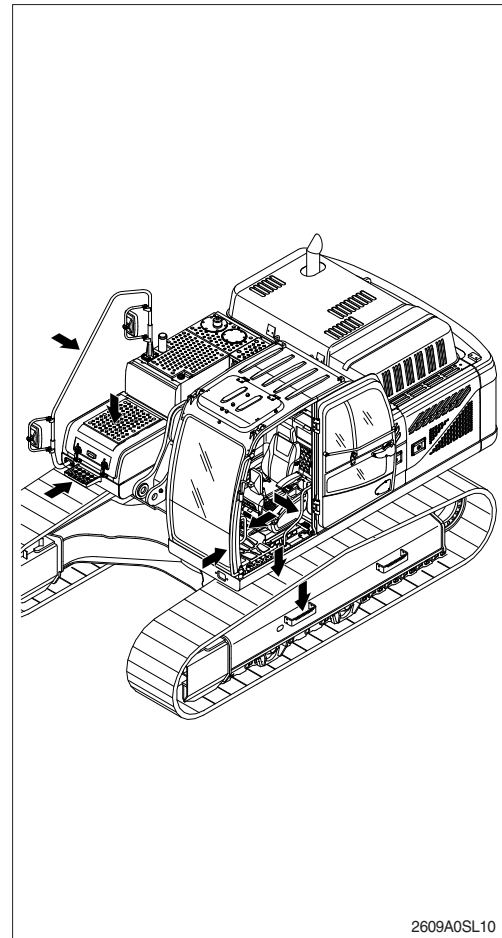

## KEEP RIDERS OFF MACHINE

Riders on a machine are subject to injury such as being struck objects and being thrown off the machine.

Only allow the operator on the machine. Keep riders off.

### 3. DURING MAINTENANCE

Stop the engine immediately when the trouble of the machine is found.

Inspect immediately the cause of trouble such as vibration, overheating and trouble in the cluster then repair.

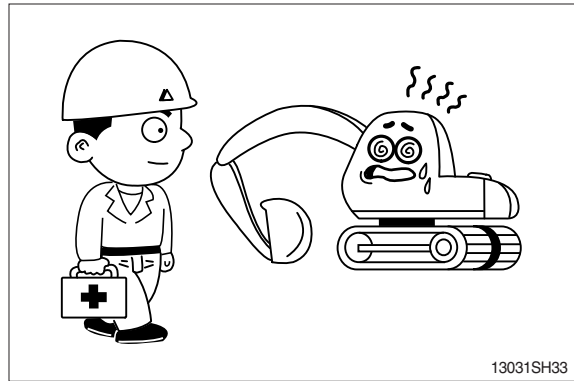

Park on a flat place and stop the engine for inspecting and repairing. Properly TAG machine is not operational. (remove start key)  
Extreme care shall be taken during maintenance work. Parts may require additional safe guard.

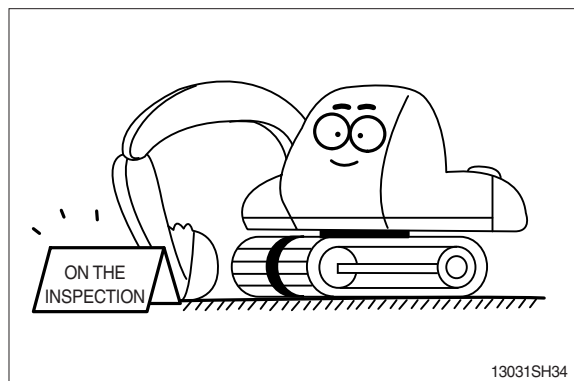

Do not remove the radiator cap from hot engine. Open the cap after the engine cools, below 50 °C (122 °F) to prevent personal injury from heated coolant spray or steam.

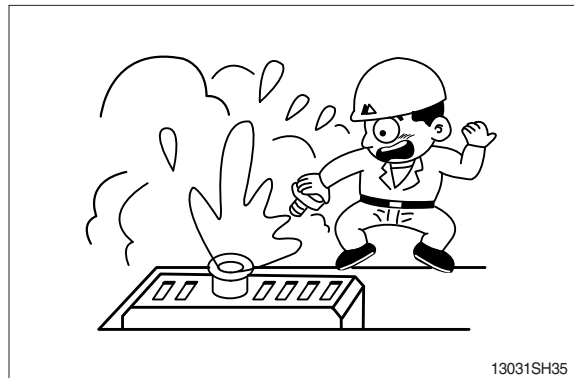

Do not work below the machine.  
Be sure to work with proper safety supports.  
Do not depend on the hydraulic cylinders to hold up the equipment and attachment.

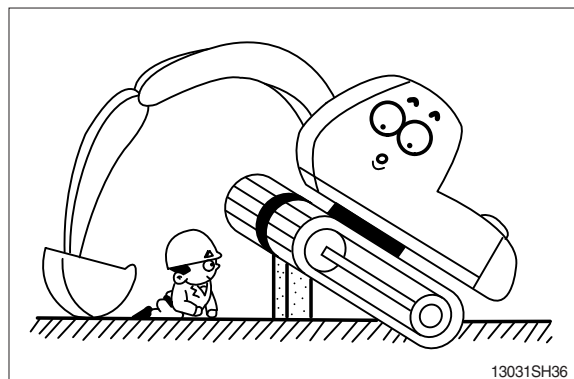

There is the danger of fire in fuel and oil.  
Store in cool and dry area, away from any open flames.

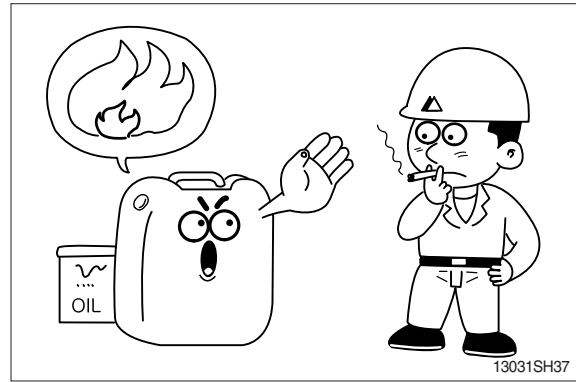

Do not touch exhaust pipe, or may cause severe burn.

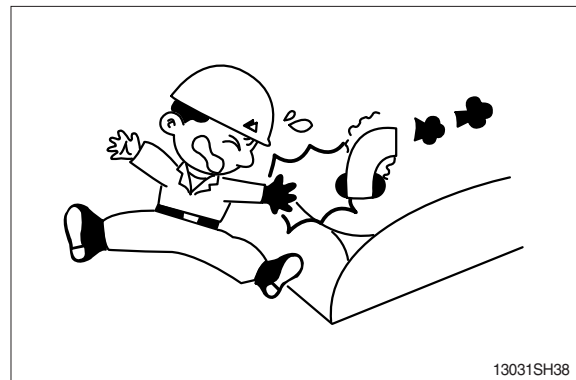

Do not open the engine hood and covers while the engine is running.



Be careful of not hitting the edges when you service engine.

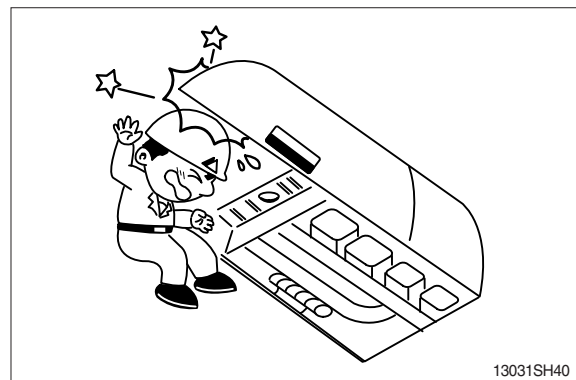

Be careful that the front window may be promptly closed.

Be sure to support stay, when the side door needs to be opened.

Be careful that the open side door may closed by the external or natural force like strong wind.



The antislip protection should be replaced if they have become worn or have been printed over.

Be sure to free of oil, water and grease etc.

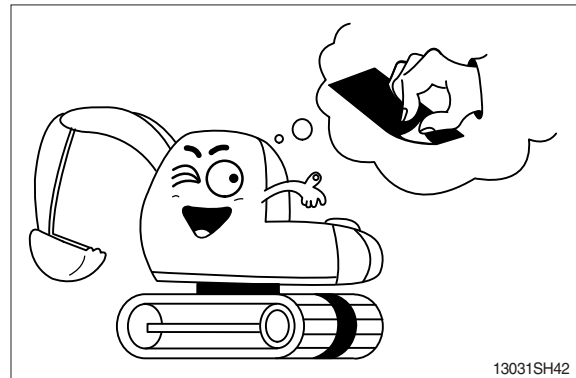

Be careful of not touching slip, fall down etc., when you work at the upper frame to service engine and/or other component.

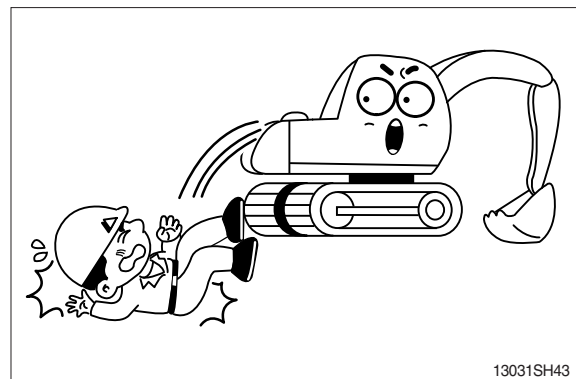

### HIGH PRESSURE GAS

Contain high pressure gas.

To avoid explosion and personal injury, do not expose to fire, do not weld, do not drill.

Relieve pressure before discharging.

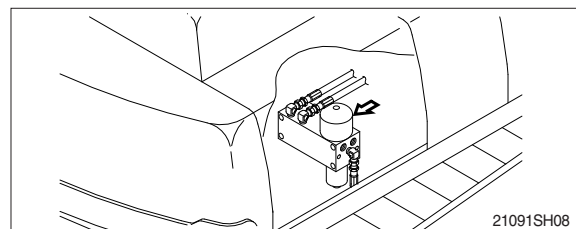

### LIFT EYES CAN FAIL

Lift eyes or tank can fail when lifting tank containing fluids resulting in possible personal injury.

Drain tank of all fluids before lifting.

## 4. PARKING

When leaving the machine after parking, lower the bucket to the ground completely and put the safety lever at parking position then remove the key.  
Lock the cab door.

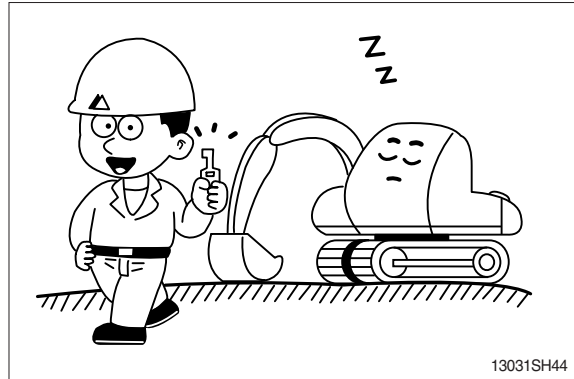

Park the machine in the flat and safe place.

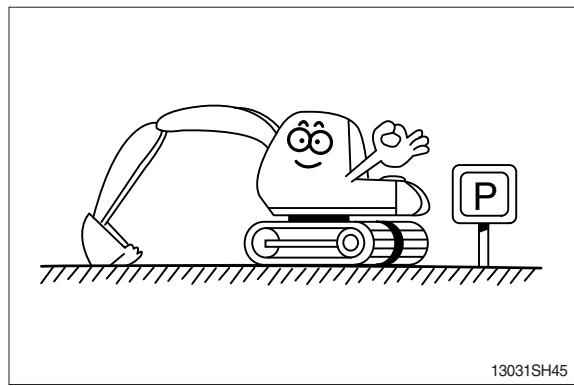

Hope you can work easily and safely observing safety rules.  
For safe operation, observe all safety rules.

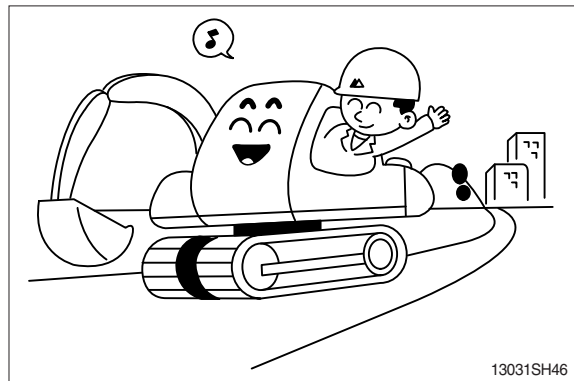



# SPECIFICATIONS

## 1. MAJOR COMPONENT

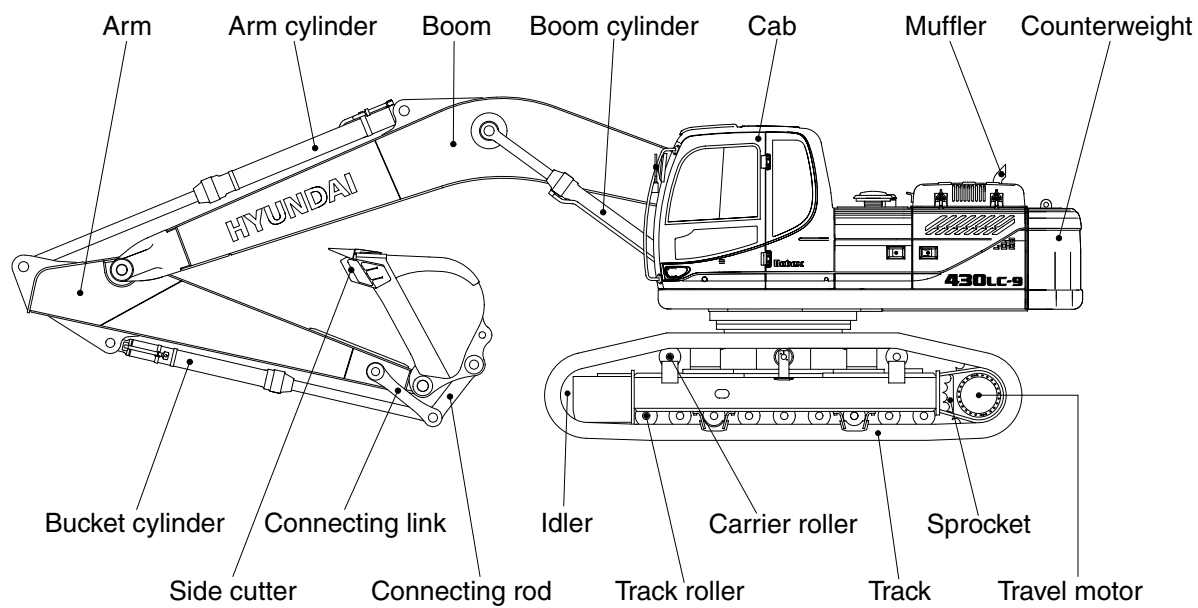
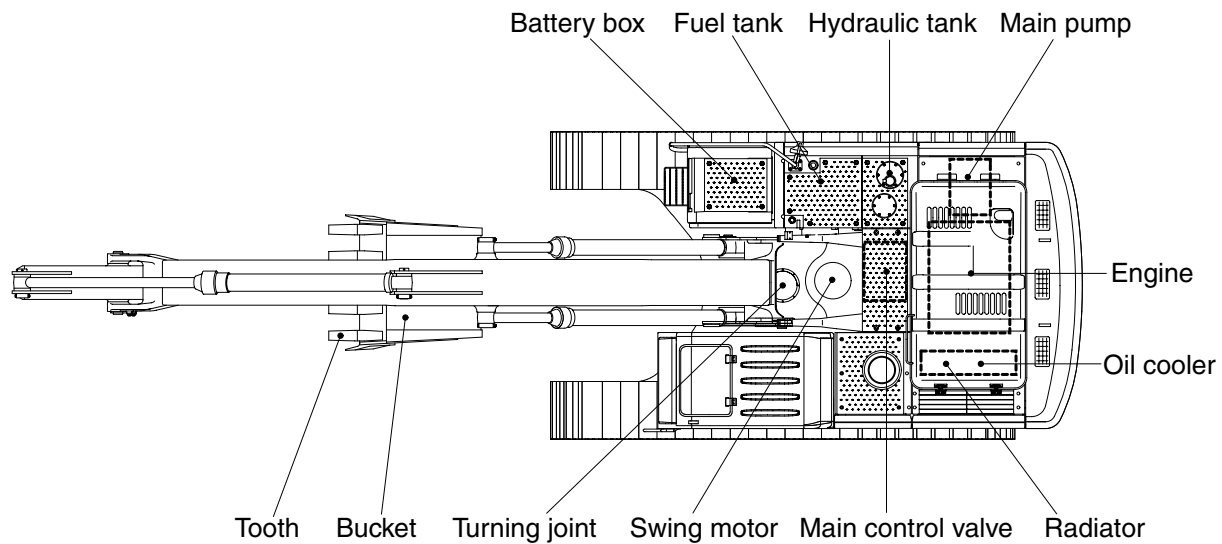

43092SP01

## 2. SPECIFICATIONS

- 6.5 m (21' 4") BOOM and 2.6 m (8' 6") ARM

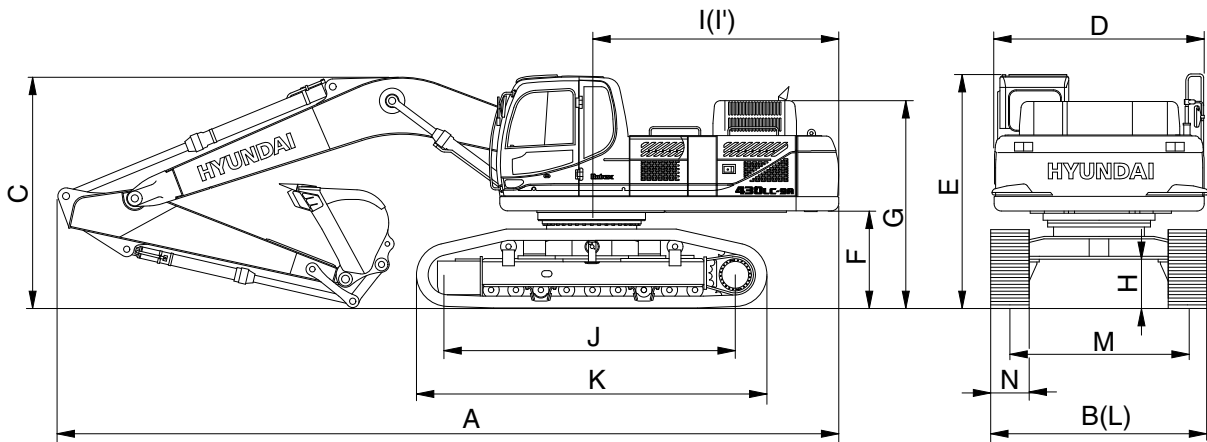

43092SP02

Description		Unit	Specification
Operating weight		kg (lb)	42600 (93920)
Bucket capacity (SAE heaped), standard		m <sup>3</sup> (yd <sup>3</sup> )	2.1 (2.75)
Overall length	A	mm (ft-in)	11240 (36' 11")
Overall width, with 600 mm shoe	B		3340 (10' 11")
Overall height	C		3780 (12' 5")
Superstructure width	D		2980 (9' 9")
Overall height of cab	E		3180 (10' 5")
Ground clearance of counterweight	F		1295 (4' 3")
Engine cover height	G		2795 (9' 2")
Minimum ground clearance	H		555 (1' 10")
Rear-end distance	I		3505 (11' 6")
Rear-end swing radius	I'		3560 (11' 8")
Distance between tumblers	J		4470 (14' 8")
Undercarriage length	K		5462 (17' 11")
Undercarriage width	L		3340 (11' 0")
Track gauge	M		2740 (9' 0")
Track shoe width, standard	N		600 (24")
Travel speed (low/high)		km/hr (mph)	3.1/5.5 (1.9/3.5)
Swing speed		rpm	9.6
Gradeability		Degree (%)	35 (70)
Ground pressure (600 mm shoe)		kgf/cm <sup>2</sup> (psi)	0.74 (10.52)
Max traction force		kg (lb)	34000 (74960)

### 3. WORKING RANGE

· 6.5 m (21' 4") BOOM

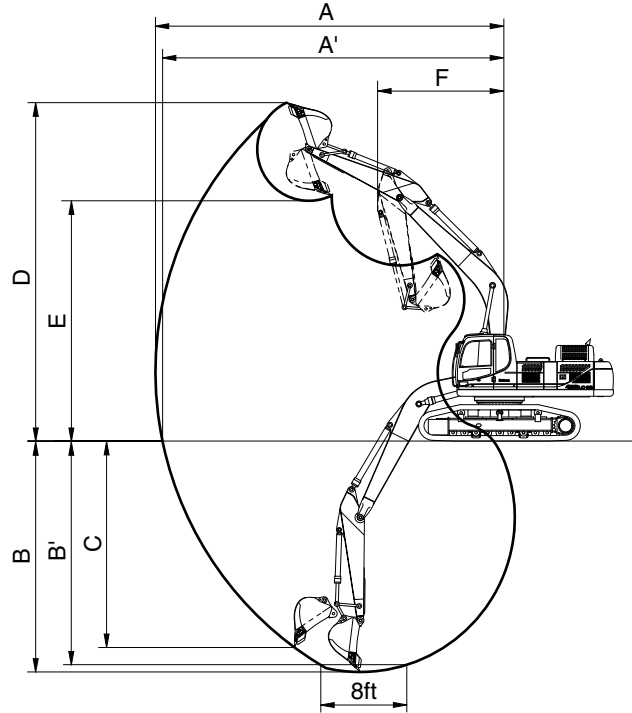

4309A2SP03

Description		2.6 m (8' 6") Arm
Max digging reach	A	10810 mm (35' 6")
Max digging reach on ground	A'	10580 mm (34' 9")
Max digging depth	B	6860 mm (22' 6")
Max digging depth (8ft level)	B'	6690 mm (21'11")
Max vertical wall digging depth	C	6000 mm (19' 8")
Max digging height	D	10710 mm (35' 2")
Max dumping height	E	7480 mm (24' 6")
Min swing radius	F	4530 mm (14'10")
Bucket digging force	SAE	200.2 [218.4] kN
		20410 [22270] kgf
		45000 [49090] lbf
	ISO	228.7 [249.5] kN
		23320 [25440] kgf
		51410 [56090] lbf
Arm crowd force	SAE	180.7 [197.2] kN
		18430 [20110] kgf
		40630 [44330] lbf
	ISO	188.0 [205.1] kN
		19170 [20910] kgf
		42260 [46100] lbf

[ ] : Power boost















## 4. WEIGHT

Item	R430LC-9A	
	kg	lb
Upperstructure assembly	16090	35470
Main frame weld assembly	3050	6720
Engine assembly	790	1740
Main pump assembly	190	420
Main control valve assembly (type 1)	340	750
Main control valve assembly (type 2)	420	930
Swing motor assembly	440	970
Hydraulic oil tank assembly	340	750
Fuel tank assembly	230	510
Counterweight	7500	16540
Cab assembly	490	1080
Lower chassis assembly	19600	43210
Track frame weld assembly	6430	14180
Swing bearing	590	1300
Travel motor assembly	620	1370
Turning joint	65	140
Track recoil spring	325	720
Idler	310	680
Carrier roller	40	90
Track roller	90	200
Track-chain assembly (600 mm standard triple grouser shoe)	2700	5950
Front attachment assembly (6.5 m boom, 2.6 m arm, 2.1 m <sup>3</sup> SAE heaped bucket)	8200	18080
6.5 m boom assembly	3050	6720
2.6 m arm assembly	1340	2950
2.1 m <sup>3</sup> SAE heaped bucket	2090	4610
Boom cylinder assembly	370	820
Arm cylinder assembly	490	1080
Bucket cylinder assembly	320	710
Bucket control linkage assembly	370	820

## 5. LIFTING CAPACITIES

1) 6.5 m (21' 4") boom, 2.6 m (8' 6") arm equipped with 2.10 m<sup>3</sup> (SAE heaped) bucket and 600 mm (24") triple grouser shoe.

·  : Rating over-front      ·  : Rating over-side or 360 degree

Load point height		Load radius												At max. reach			
		1.5 m (5.0 ft)		3.0 m (10.0 ft)		4.5 m (15.0 ft)		6.0 m (20.0 ft)		7.5 m (25.0 ft)		9.0 m (30.0 ft)		Capacity		Reach	
																m (ft)	
9.0 m (30 ft)	kg														*6020	*6020	7.12
	lb														*13270	*13270	(23.4)
7.5 m (25.0 ft)	kg														*5940	*5940	8.39
	lb														*13100	*13100	(27.5)
6.0 m (20.0 ft)	kg							*7070	*7070	*6570	*6570				*6020	4960	9.20
	lb							*15590	*15590	*14480	*14480				*13270	10930	(30.2)
4.5 m (15.0 ft)	kg					*10890	*10890	*8400	*8400	*7190	*7190				*6170	4340	9.69
	lb					*24010	*24010	*18520	*18520	*15850	*15850				*13600	9570	(31.8)
3.0 m (10.0 ft)	kg					*14190	*14190	*9990	*9990	*8020	6970	*5280	4940		*6370	4040	9.90
	lb					*31280	*31280	*22020	*22020	*17680	15370	*11640	10890		*14040	8910	(32.5)
1.5 m (5.0 ft)	kg					*16530	14990	*11390	9570	*8820	6650	*6160	4800		*6600	3990	9.85
	lb					*36440	33050	*25110	21100	*19440	14660	*13580	10580		*14550	8800	(32.3)
Ground Line	kg					*17350	14580	*12240	9210	*9360	6430				*6850	4200	9.55
	lb					*38250	32140	*26980	20300	*20640	14180				*15100	9260	(31.3)
-1.5 m (-5.0 ft)	kg			*18300	*18300	*17100	14550	*12400	9080	*9440	6350				*7060	4750	8.95
	lb			*40340	*40340	*37700	32080	*27340	20020	*20810	14000				*15560	10470	(29.4)
-3.0 m (-10.0 ft)	kg	*20700	*20700	*22350	*22350	*15190	14750	*11730	9160						*7110	5920	8.00
	lb	*45640	*45640	*49270	*49270	*35080	32520	*25860	20190						*15670	13050	(26.2)
-4.5 m (-15.0 ft)	kg			*18450	*18450	*13360	*13360	*9560	9530						*6560	*6560	6.49
	lb			*40680	*40680	*29450	*29450	*21080	21010						*14460	*14460	(21.3)

- Note
1. Lifting capacity are based on SAE J1097 and ISO 10567.
  2. Lifting capacity of the ROBEX series does not exceed 75% of tipping load with the machine on firm, level ground or 87% of full hydraulic capacity.
  3. The load point is a hook located on the back of the bucket.
  4. \* indicates load limited by hydraulic capacity.

## 6. BUCKET SELECTION GUIDE

### 1) ROCK-HEAVY DUTY

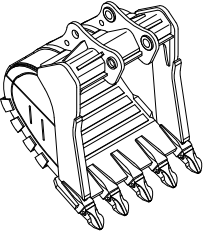
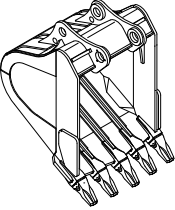
	
2.10 m <sup>3</sup> SAE heaped bucket	1.90 m <sup>3</sup> SAE heaped bucket

Capacity		Width		Weight	Recommendation	
					6.5 m (21' 4") boom	
SAE heaped	CECE heaped	Without side cutter	With side cutter		2.6 m arm (8' 6")	3.2 m arm (10' 6")
1.90 m <sup>3</sup> (2.49 yd <sup>3</sup> )	1.65 m <sup>3</sup> (2.16 yd <sup>3</sup> )	1670 mm (65.7")	-	1990 kg (4390 lb)		
2.10 m <sup>3</sup> (2.75 yd <sup>3</sup> )	1.84 m <sup>3</sup> (2.41 yd <sup>3</sup> )	1800 mm (70.9")	-	2090 kg (4610 lb)		

Applicable for materials with density of 2000 kg/m<sup>3</sup> (3370 lb/yd<sup>3</sup>) or less

Applicable for materials with density of 1600 kg/m<sup>3</sup> (2700 lb/yd<sup>3</sup>) or less

Applicable for materials with density of 1100 kg/m<sup>3</sup> (1850 lb/yd<sup>3</sup>) or less

## 7. UNDERCARRIAGE

### 1) TRACKS

X-leg type center frame is integrally welded with reinforced box-section track frames. The design includes dry tracks, lubricated rollers, idlers, sprockets, hydraulic track adjusters with shock absorbing springs and assembled track-type tractor shoes with triple grousers.

### 2) TYPES OF SHOES

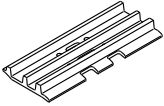
Model	Shapes		Triple grouser				
							
R430LC-9A	Shoe width	mm (in)	600 (24)	700 (28)	750 (30)	800 (32)	900 (36)
	Operating weight	kg (lb)	42600 (93920)	43140 (95110)	43410 (95700)	43680 (96300)	44220 (97490)
	Ground pressure	kgf/cm <sup>2</sup> (psi)	0.74 (10.52)	0.64 (9.10)	0.60 (8.53)	0.57 (8.11)	0.51 (7.25)
	Overall width	mm (ft-in)	3340 (10' 11")	3440 (11' 3")	3490 (11' 5")	3540 (11' 7")	3640 (11' 11")

### 3) NUMBER OF ROLLERS AND SHOES ON EACH SIDE

Item	Quantity
Carrier rollers	2 EA
Track rollers	9 EA
Track shoes	53 EA

#### 4) SELECTION OF TRACK SHOE

Suitable track shoes should be selected according to operating conditions.

##### Method of selecting shoes

Confirm the category from the list of applications in **table 2**, then use **table 1** to select the shoe. Wide shoes (categories B and C) have limitations on applications. Before using wide shoes, check the precautions, then investigate and study the operating conditions to confirm if these shoes are suitable.

Select the narrowest shoe possible to meet the required flotation and ground pressure. Application of wider shoes than recommendations will cause unexpected problem such as bending of shoes, crack of link, breakage of pin, loosening of shoe bolts and the other various problems.

※ **Table 1**

Track shoe	Specification	Category
600 mm triple grouser	Standard	A
700 mm triple grouser	Option	B
750 mm triple grouser	Option	B
800 mm triple grouser	Option	C
900 mm triple grouser	Option	C

※ **Table 2**

Category	Applications	Applications
A	Rocky ground, river beds, normal soil	<ul style="list-style-type: none"> <li>Travel at low speed on rough ground with large obstacles such as boulders or fallen trees</li> </ul>
B	Normal soil, soft ground	<ul style="list-style-type: none"> <li>These shoes cannot be used on rough ground with large obstacles such as boulders or fallen trees</li> <li>Travel at high speed only on flat ground</li> <li>Travel slowly at low speed if it is impossible to avoid going over obstacles</li> </ul>
C	Extremely soft ground (swampy ground)	<ul style="list-style-type: none"> <li>Use the shoes only in the conditions that the machine sinks and it is impossible to use the shoes of category A or B</li> <li>These shoes cannot be used on rough ground with large obstacles such as boulders or fallen trees</li> <li>Travel at high speed only on flat ground</li> <li>Travel slowly at low speed if it is impossible to avoid going over obstacles</li> </ul>



## 8. SPECIFICATIONS FOR MAJOR COMPONENTS

### 1) ENGINE

Item	Specification
Model	Cummins QSL9
Type	4-cycle turbocharged charger air cooled diesel engine
Cooling method	Water cooling
Number of cylinders and arrangement	6 cylinders, in-line
Firing order	1-5-3-6-2-4
Combustion chamber type	Direct injection type
Cylinder bore × stroke	114 × 145 mm (4.49" × 5.69")
Piston displacement	8900 cc (543 cu in)
Compression ratio	17.8 : 1
Rated gross horse power (SAE J1995)	310 Hp at 1650 rpm (231 kW at 1650 rpm)
Maximum torque	148 kgf · m (1070 lbf · ft) at 1400 rpm
Engine oil quantity	30 l (7.9 U.S. gal)
Wet weight	708 kg (1560 lb)
Low idling speed	800 ± 100 rpm
High idling speed	1700 + 50 rpm
Rated fuel consumption	161.5 g/Hp · hr at 1650 rpm
Starting motor	Denso (24V-7.8 kW)
Alternator	Denso 24V-95A
Battery	2 × 12V × 160Ah

### 2) MAIN PUMP

Item	Specification
Type	Variable displacement tandem axis piston pumps
Capacity	2 × 185 cc/rev
Maximum pressure	330 kgf/cm <sup>2</sup> (4690 psi) [360 kgf/cm <sup>2</sup> (5120 psi)]
Rated oil flow	2 × 315 l/min (83.2 U.S. gpm / 69.3 U.K. gpm)
Rated speed	1700 rpm

[ ] : Power boost

### 3) GEAR PUMP

Item	Specification
Type	Fixed displacement gear pump single stage
Capacity	15cc/rev
Maximum pressure	40 kgf/cm <sup>2</sup> (570 psi)
Rated oil flow	25.5 ℓ /min (6.7 U.S. gpm/5.6 U.K. gpm)

### 4) MAIN CONTROL VALVE

Item	Specification
Type	9 spools
Operating method	Hydraulic pilot system
Main relief valve pressure	330 kgf/cm <sup>2</sup> (4690 psi) [360 kgf/cm <sup>2</sup> (5120 psi)]
Overload relief valve pressure	390 kgf/cm <sup>2</sup> (5550 psi)

[ ] : Power boost

### 5) SWING MOTOR

Item	Specification
Type	Axial piston motor
Capacity	250 cc/rev
Relief pressure	290 kgf/cm <sup>2</sup> (4120 psi)
Braking system	Automatic, spring applied hydraulic released
Braking torque	107 kgf · m (773 lbf · ft)
Brake release pressure	30~50 kgf/cm <sup>2</sup> (427~711 psi)
Reduction gear type	2 - stage planetary

### 6) TRAVEL MOTOR

Item	Specification
Type	Variable displacement axial piston motor
Relief pressure	360 kgf/cm <sup>2</sup> (5120 psi)
Capacity (max / min)	282.6/160.8 cc/rev
Reduction gear type	2-stage planetary
Braking system	Automatic, spring applied hydraulic released
Brake release pressure	15.3 kgf/cm <sup>2</sup> (218 psi)
Braking torque	120 kgf · m (868 lbf · ft)

## 7) CYLINDER

Item		Specification
Boom cylinder	Bore dia × Rod dia × Stroke	∅ 160 × ∅ 110 × 1500 mm
	Cushion	Extend only
Arm cylinder	Bore dia × Rod dia × Stroke	∅ 170 × ∅ 120 × 1760 mm
	Cushion	Extend and retract
Bucket cylinder	Bore dia × Rod dia × Stroke	∅ 150 × ∅ 105 × 1295 mm
	Cushion	Extend only

※ Discoloration of cylinder rod can occur when the friction reduction additive of lubrication oil spreads on the rod surface.

※ Discoloration does not cause any harmful effect on the cylinder performance.

## 8) SHOE

Item		Width	Ground pressure	Link quantity	Overall width
R430LC-9A	Standard	600 mm (24")	0.74 kgf/cm <sup>2</sup> (10.52 psi)	53	3340 mm (10' 11")
	Option	700 mm (28")	0.64 kgf/cm <sup>2</sup> (9.10 psi)	53	3440 mm (11' 3")
		750 mm (30")	0.60 kgf/cm <sup>2</sup> (8.53 psi)	53	3490 mm (11' 5")
		800 mm (32")	0.57 kgf/cm <sup>2</sup> (8.11 psi)	53	3540 mm (11' 7")
		900 mm (36")	0.51 kgf/cm <sup>2</sup> (7.25 psi)	53	3640 mm (11' 11")

## 9) BUCKET

Item		Capacity		Tooth quantity	Width	
		SAE heaped	CECE heaped		Without side cutter	With side cutter
R430LC-9A	Standard	◎2.10 m <sup>3</sup> (2.75 yd <sup>3</sup> )	1.84 m <sup>3</sup> (2.41 yd <sup>3</sup> )	5	1800 mm (70.9")	-
	Optioin	◎1.90 m <sup>3</sup> (2.49 yd <sup>3</sup> )	1.65 m <sup>3</sup> (2.16 yd <sup>3</sup> )	5	1660 mm (65.6")	-

◎ : Rock - heavy duty bucket

## 9. RECOMMENDED OILS

Use only oils listed below. Do not mix different brand oil.

Please use HYUNDAI genuine oil and grease.

Service point	Kind of fluid	Capacity ℓ (U.S. gal)	Ambient temperature °C ( °F)						
			-50 (-58)	-30 (-22)	-20 (-4)	-10 (14)	0 (32)	10 (50)	20 (68)
Engine oil pan	Engine oil	30 (7.9)	★SAE 5W-40						
			SAE 30						
			SAE 10W						
			SAE 10W-30						
			SAE 15W-40						
Swing drive	Gear oil	8.0 (2.1)	★SAE 75W-90						
Final drive		12×2 (3.2×2)	SAE 80W-90						
Hydraulic tank	Hydraulic oil	Tank : 210 (55.5) System : 410 (108.3)	★ISO VG 15						
			ISO VG 32						
			ISO VG 46						
			ISO VG 68						
Fuel tank	Diesel fuel★1	550 (145.3)	★ASTM D975 NO.1						
			ASTM D975 NO.2						
Fitting (grease nipple)	Grease	As required	★NLGI NO.1						
			NLGI NO.2						
Radiator (reservoir tank)	Mixture of antifreeze and soft water★2	45 (13.7)	Ethylene glycol base permanent type (50 : 50)						
			★Ethylene glycol base permanent type (60 : 40)						

**SAE** : Society of Automotive Engineers

**API** : American Petroleum Institute

**ISO** : International Organization for Standardization

**NLGI** : National Lubricating Grease Institute

**ASTM** : American Society of Testing and Material

★ : Cold region

Russia, CIS, Mongolia

★1 : Ultra low sulfur diesel

- sulfur content ≤ 15 ppm

★2 : Soft water

City water or distilled water

# CONTROL DEVICES

## 1. CAB DEVICES

1) The ergonomically designed console box and suspension type seat provide the operator with comfort.

### 2) ELECTRONIC MONITOR SYSTEM

- (1) The centralized electronic monitor system allows the status and conditions of the machine to be monitored at a glance.
- (2) It is equipped with a safety warning system for early detection of machine malfunction.

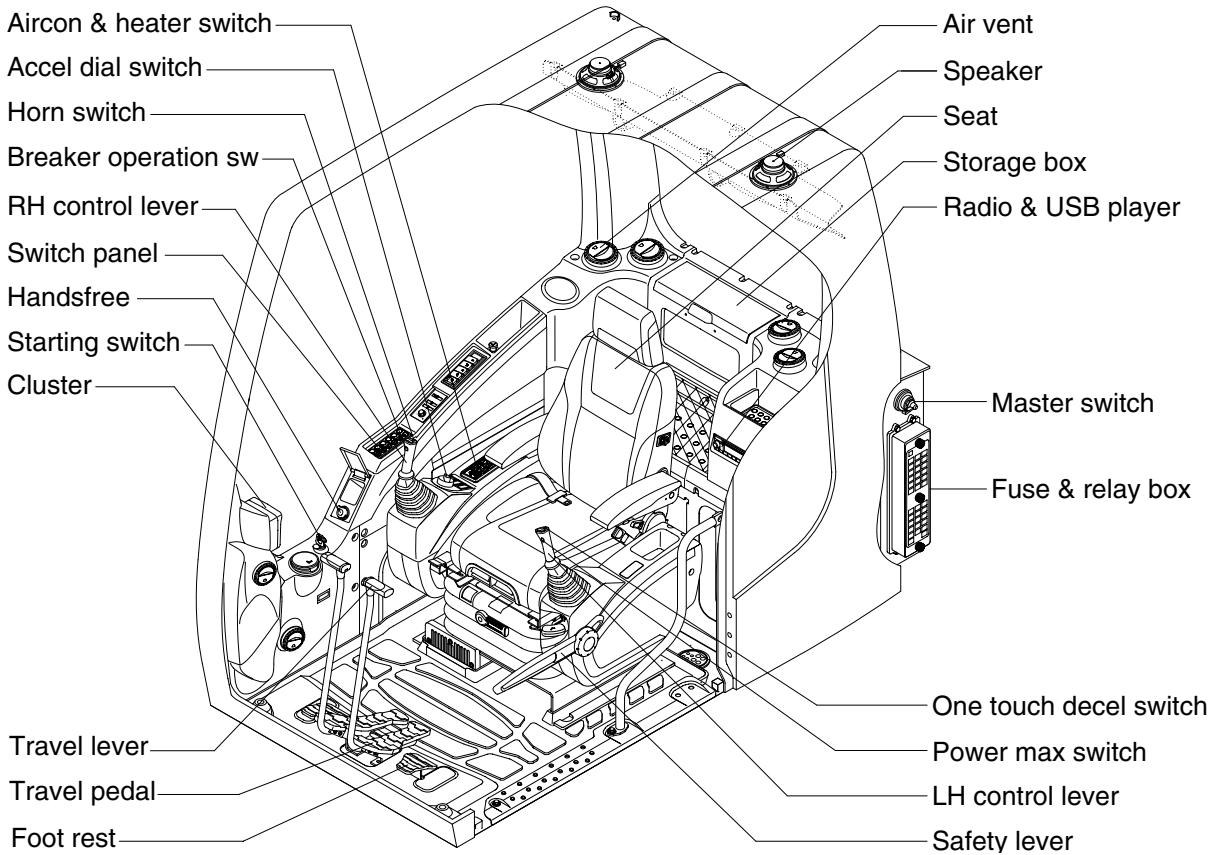

2609A3CD01

## 2. CLUSTER

### 1) STRUCTURE

The cluster consists of LCD and switches as shown below. The LCD is to warn the operator in case of abnormal machine operation or conditions for the appropriate operation and inspection. Also, The LCD is to set and display for modes, monitoring and utilities with the switches.

The switches or touch screen are to set the machine operation modes.

- ※ The cluster installed on this machine does not entirely guarantee the condition of the machine. Daily inspection should be performed according to chapter 6, Maintenance.
- ※ When the cluster provides a warning immediately check the problem, and perform the required action.

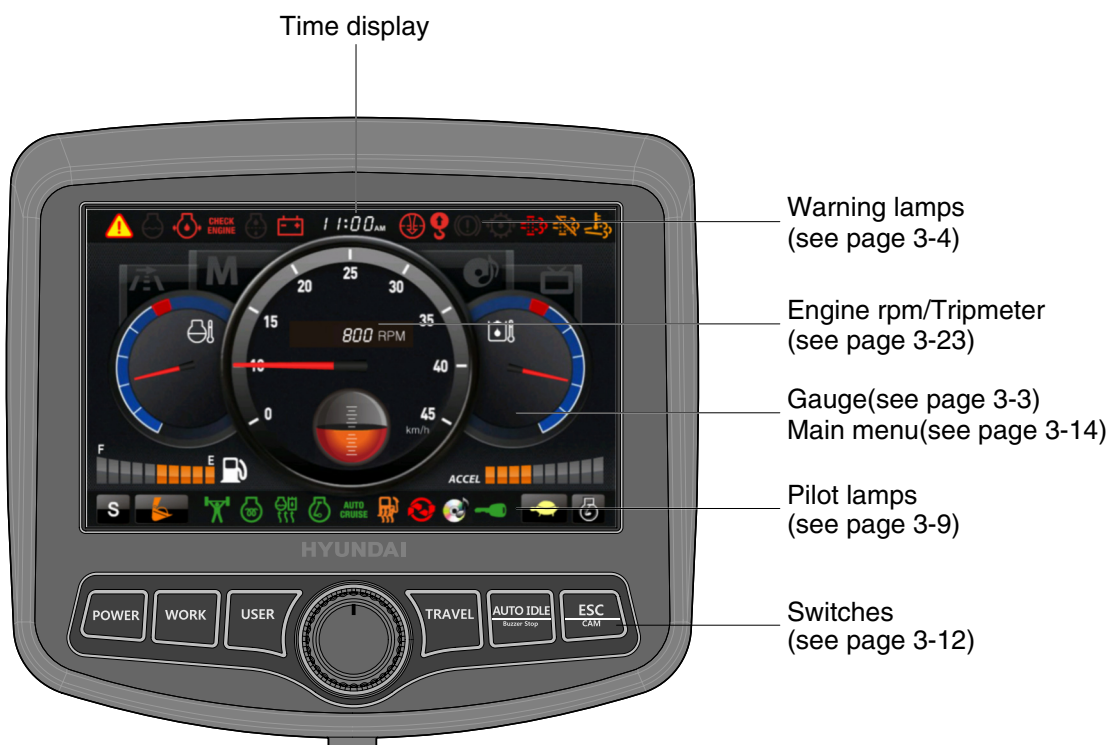

2609A3CD12

- ※ The warning lamp pops up and/or blinks and the buzzer sounds when the machine has a problem.

The warning lamp blinks until the problem is cleared. Refer to page 3-4 for details.

- ※ This cluster is adjustable.

- Vertical (forward/backward) : each 15°
- Horizontal (left only) : 15°

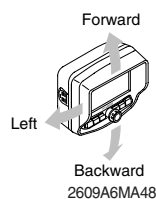

## 2) GAUGE

### (1) Operation screen

When you first turn starting switch ON, the operation screen will appear.

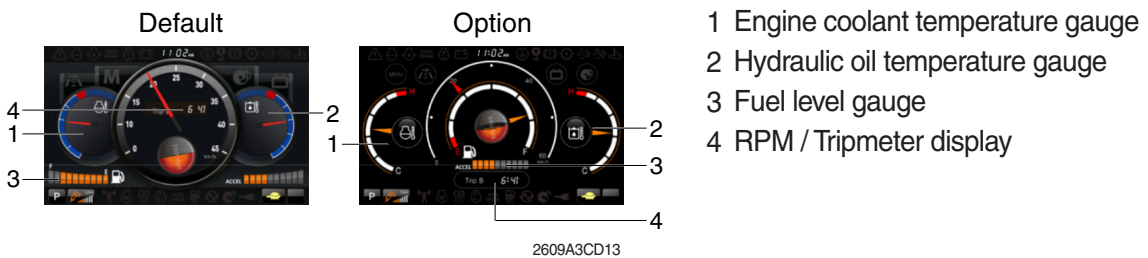

※ Operation screen type can be set by the screen type menu of the display.

Refer to page 3-24 for details.

### (2) Engine coolant temperature gauge

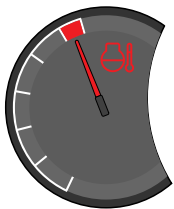



2609A3CD14

① This gauge indicates the temperature of coolant.

· White range : 40-107°C (104-225°F)

· Red range : Above 107°C (225°F)

② If the indicator is in the red range or  lamp blinks in red, turn OFF the engine and check the engine cooling system.

※ If the gauge indicates the red range or  lamp blinks in red even though the machine is on the normal condition, check the electric device as that can be caused by the poor connection of electricity or sensor.

### (3) Hydraulic oil temperature gauge

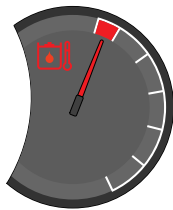



2609A3CD15

① This gauge indicates the temperature of hydraulic oil.

· White range : 40-105°C(104-221°F)

· Red range : Above 105°C(221°F)

② If the indicator is in the red range or  lamp blinks is red, reduce the load on the system. If the gauge stays in the red range, stop the machine and check the cause of the problem.

※ If the gauge indicates the red range or  lamp blinks in red even though the machine is on the normal condition, check the electric device as that can be caused by the poor connection of electricity or sensor.

### (4) Fuel level gauge



2609A3CD16

① This gauge indicates the amount of fuel in the fuel tank.

② Fill the fuel when the red range, or  lamp blinks in red.

※ If the gauge indicates the red range or  lamp blinks in red even though the machine is on the normal condition, check the electric device as that can be caused by the poor connection of electricity or sensor.

### (5) RPM / Tripmeter display

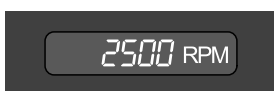

2609A3CD17

① This displays the engine speed or the tripmeter.

※ Refer to page 3-25 for details.

### 3) WARNING LAMPS

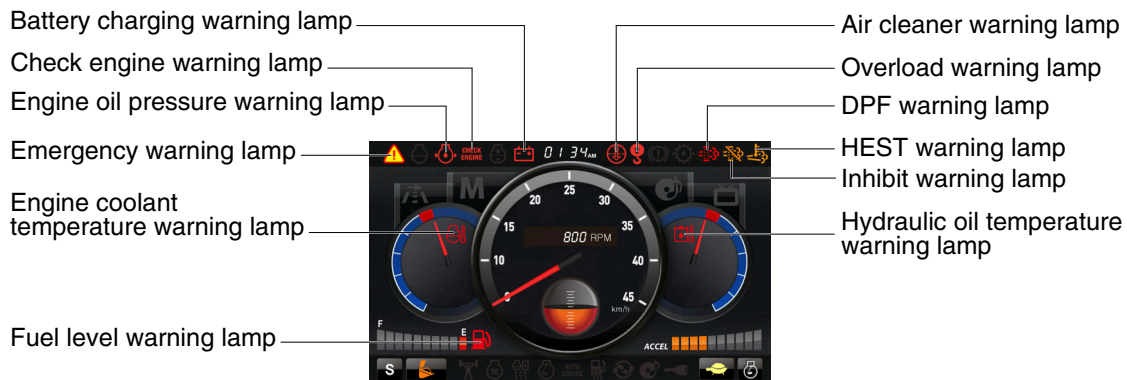

2609A3CD18

※ Each warning lamp on the top of the LCD pops up on the center of LCD and the buzzer sounds when the each warning is happened. The pop-up warning lamp moves to the original position and blinks when the select switch is pushed. And the buzzer stops. Refer to page 3-13 for the select switch.

#### (1) Engine coolant temperature warning lamp

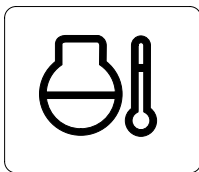

21093CD08A

- ① Engine coolant temperature warning is indicated two steps.
  - 103°C over : The lamp blinks and the buzzer sounds.
  - 107°C over : The lamp pops up on the center of LCD and the buzzer sounds.
- ② The pop-up lamp moves to the original position and blinks when the select switch is pushed. Also, the buzzer stops and lamp keeps blink.
- ③ Check the cooling system when the lamp keeps ON.

#### (2) Hydraulic oil temperature warning lamp

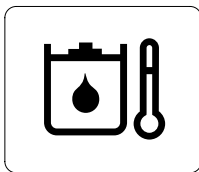

21093CD08C

- ① Hydraulic oil temperature warning is indicated two steps.
  - 100°C over : The lamp blinks and the buzzer sounds.
  - 105°C over : The lamp pops up on the center of LCD and the buzzer sounds.
- ② The pop-up lamp moves to the original position and blinks when the select switch is pushed. Also, the buzzer stops and lamp keeps blink.
- ③ Check the hydraulic oil level and hydraulic oil cooling system.

#### (3) Fuel level warning lamp



21093CD08B

- ① This warning lamp blinks and the buzzer sounds when the level of fuel is below 75 ℓ (19.8 U.S. gal).
- ② Fill the fuel immediately when the lamp blinks.



#### (4) Emergency warning lamp



21093CD30

- ① This lamp pops up and the buzzer sounds when each of the below warnings is happened.
  - Engine coolant overheating (over 107°C)
  - Hydraulic oil overheating (over 105°C)
  - Pump EPPR circuit abnormal or open
  - Attachment flow EPPR circuit abnormal or open
  - MCU input voltage abnormal
  - Accel dial circuit abnormal or open
  - Cluster communication data error
  - Engine ECM communication data error
- ※ **The pop-up warning lamp moves to the original position and blinks when the select switch is pushed. Also the buzzer stops. This is same as following warning lamps.**
- ② When this warning lamp blinks, machine must be checked and serviced immediately.

#### (5) Engine oil pressure warning lamp

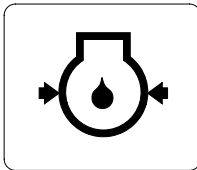

21093CD32

- ① This lamp blinks when the engine oil pressure is low.
- ② If the lamp blinks, shut OFF the engine immediately. Check oil level.

#### (6) Check engine warning lamp

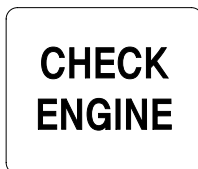

21093CD33

- ① This lamp blinks when the communication between MCU and engine ECM on the engine is abnormal, or if the cluster received any fault code from engine ECM.
- ② Check the communication line between them.  
If the communication line is OK, then check the fault codes on the cluster.
- ③ Also, this lamp pops up when the level of DPF soot is high.
- ※ Refer to the page 3-6 for the DPF warning lamp.

#### (7) Battery charging warning lamp

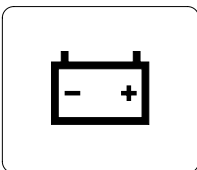

21093CD34

- ① This lamp blinks when the battery charging voltage is low.
- ② Check the battery charging circuit when this lamp blinks.

### (8) Air cleaner warning lamp

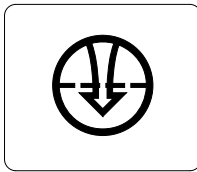

21093CD35

- ① This lamp blinks when the filter of air cleaner is clogged.
- ② Check the filter and clean or replace it.

### (9) Overload warning lamp (opt)

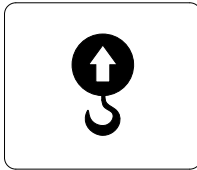

21093CD36

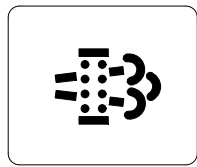

- ① When the machine is overload, the overload warning lamp blinks during the overload switch is ON. (if equipped)
- ② Reduce the machine load.

### (10) DPF (diesel particulate filter) warning lamp



2609A3CD19

- ① This warning lamp lights ON or blinks when the regeneration is needed as table below.
- ※ Consequences of delaying regeneration
- Poor performance caused by increasing exhaust gas pressure.
  - Higher fuel consumption
  - Shorter filter lifetime

Condition	Warning lamp				Remedy
	DPF		Check engine	Stop engine	
	Automatic regeneration (unfunction)	Automatic regeneration (function)	 (pop up)	 (pop up)	
Normal	Off	Off	Off	Off	· Automatic regeneration
Soot low	On	Off	Off	Off	· Automatic or manual regeneration · When automatic regeneration start function DPF lamp automatically switched off
Soot midium	Blink	Off	Off	Off	· Initiate a manual regeneration as following page (When automatic regeneration did not work) · Engine power may be reduced automatically (soot medium)
Soot high	Blink	Off	On	Off	· Automatic regeneration did not work · Initiate a manual regeneration · Engine power and speed will be reduced automatically
Stop	Off	Off	Off	On	· Stop the engine immediatary. · Please contact your Hyundai service center or local dealer.

\* Automatic regeneration start function depends on inside temperature of aftertreatment device.

※ Manual regeneration method of DPF

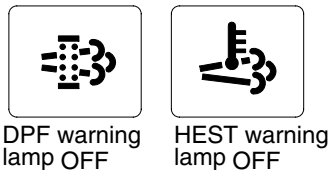
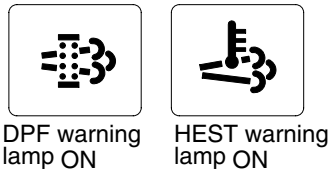
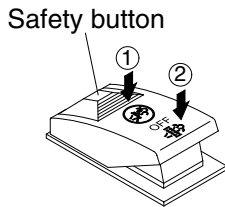

2609A3CD143

※ Manual regeneration applies if the machine is in a fireproof area and there is no plan to turn off the machine during the regeneration.

- ① Stop and park the machine.
- ② Select user mode and set the engine speed to minimum speed.

- ③ Return to the operation screen.

- ④ Pull the safety button and push the switch to position ② to initiate the manual regeneration of DPF.

※ Refer to the page 3-31 for the switch operation.

※ The engine speed may increase to 950~1050 rpm and DPF regeneration begins and it will take approximately 20~30 minutes.

- ⑤ The DPF and HEST warning lamp will light ON during the regeneration function is operating.

- ⑥ The DPF and/or HEST warning lamp will light OFF when the regeneration function is completed.

(11) HEST (High exhaust system temperature) warning lamp

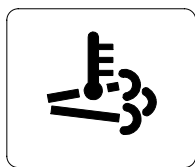

2609A3CD21

- ① This warning lamp indicates, when illuminated, that exhaust temperatures are high due to regeneration of the DPF.
- ② The lamp will also illuminate during a manual regeneration.
- ③ When this lamp is illuminated, be sure the exhaust pipe outlet is not directed at any surface or material that can melt, burn, or explode.

▲ When this lamp is illuminated, the exhaust gas temperature could reach 800°C [1500°F], which is hot enough to ignite or melt common materials, and to burn people.

※ The lamp does not signify the need for any kind of equipment or engine service; It merely alerts the equipment operator to high exhaust temperatures. It will be common for the lamp to illuminate on and off during normal equipment operation as the engine completes regeneration.

(12) DPF regeneration inhibit warning lamp

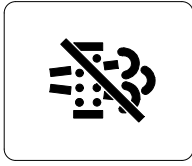

2609A3CD20

① This warning lamp indicates, when illuminated, the DPF switch is pushed inhibit position, therefore automatic and manual regeneration can not occur.





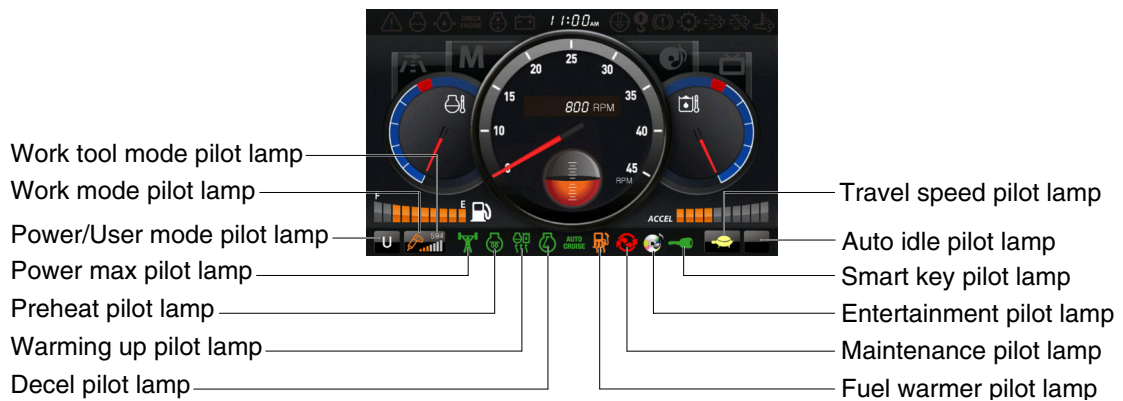





※ Refer to the page 3-31 for the DPF switch.

## 4) PILOT LAMPS



2609A3CD22

### (1) Mode pilot lamps

No	Mode	Pilot lamp	Selected mode
1	Power mode		Heavy duty power work mode
			Standard power mode
			Economy power mode
2	User mode		User preferable power mode
3	Work mode		General operation mode
			Breaker operation mode
			Crusher operation mode
4	Travel mode		Low speed traveling
			High speed traveling
5	Auto idle mode		Auto idle
6	Work tool mode		Oil flow level of breaker or crusher mode

### (2) Power max pilot lamp



21093CD38

- ① The lamp will be ON when pushing power max switch on the LH RCV lever.
  - ② The power max function is operated maximum 8 seconds.
- ※ Refer to the page 3-30 for power max function.

### (3) Preheat pilot lamp

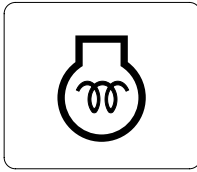

21093CD39

- ① Turning the start key switch ON position starts preheating in cold weather.
- ② Start the engine after this lamp is OFF.

### (4) Warming up pilot lamp

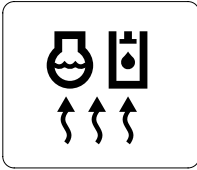

21093CD40

- ① This lamp is turned ON when the coolant temperature is below 30°C (86°F).
- ② The automatic warming up is cancelled when the engine coolant temperature is above 30°C, or when 10 minutes have passed since starting the engine.

### (5) Decel pilot lamp



21093CD41

- ① Operating one touch decel switch on the RCV lever makes the lamp ON.
  - ② Also, the lamp will be ON and engine speed will be lowered automatically to save fuel consumption when all levers and pedals are at neutral position, and the auto idle function is selected.
- ※ **One touch decel is not available when the auto idle pilot lamp is turned ON.**
- ※ **Refer to the page 3-30.**

### (6) Fuel warmer pilot lamp

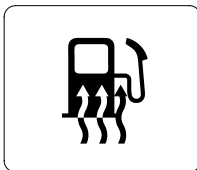

21093CD43

- ① This lamp is turned ON when the coolant temperature is below 10°C (50°F) or the hydraulic oil temperature 20°C (68°F).
- ② The automatic fuel warming is cancelled when the engine coolant temperature is above 60°C, or the hydraulic oil temperature is above 45°C since the start switch was ON position.

### (7) Maintenance pilot lamp

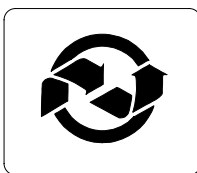

2609A3CD23

- ① This lamp will be ON when the consuming parts are needed to change or replace. It means that the change or replacement interval of the consuming parts remains below 30 hours.
  - ② Check the message in maintenance information of main menu. Also, this lamp lights ON for 3 minutes when the start switch is ON position.
- ※ **Refer to the page 3-18.**

**(8) Entertainment pilot lamp**

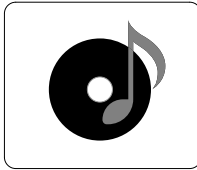

2609A3CD133

- ① This lamp is on when MP4 or video files are playing.
- ※ **Refer to the page 3-24.**

**(9) Smart key pilot lamp (opt)**

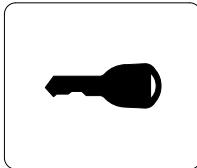

2609A3CD132

- ① This lamp is ON when the engine is started by the start button.
- ② This lamp is red when the a authentication fails, green when succeeds.
- ※ **Refer to the page 3-20.**

## 5) SWITCHES

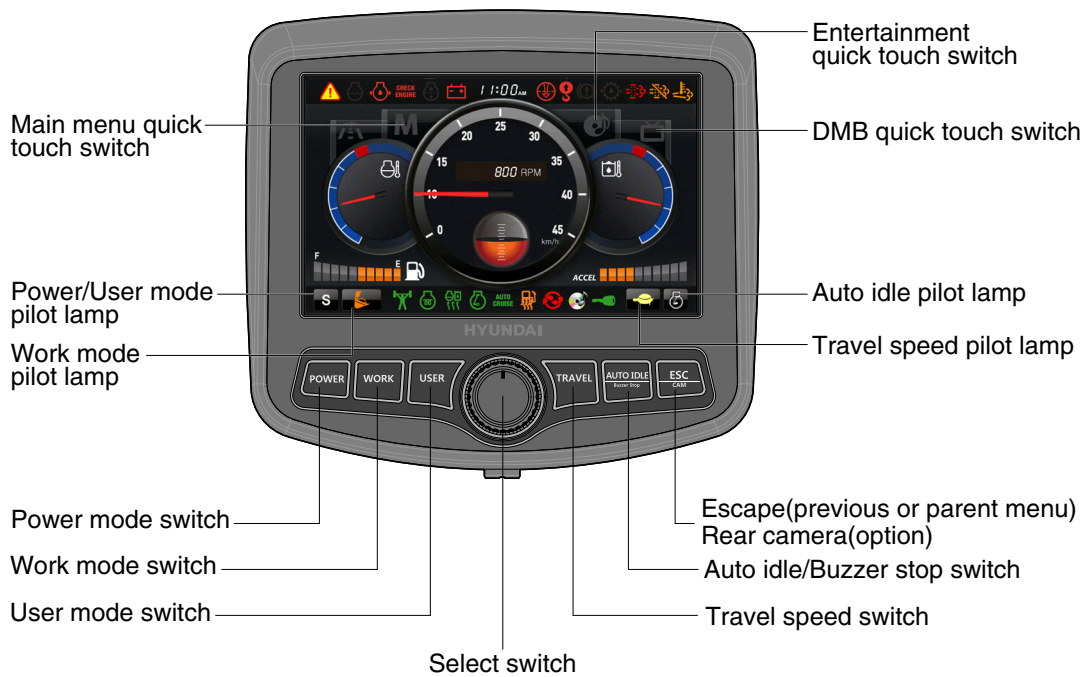

2609A3CD24

※ When the switches are selected, the pilot lamps are displayed on the LCD. Refer to the page 3-9 for details.

### (1) Power mode switch

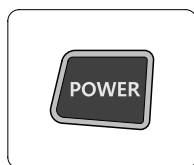



2609A3CD25

- This switch is to select the machine power mode and selected power mode pilot lamp is displayed on the pilot lamp position.
  - P : Heavy duty power work.
  - S : Standard power work.
  - E : Economy power work.
- The pilot lamp changes E → S → P → E in order.

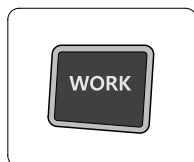
### (2) Work mode switch



2609A3CD26

- This switch is to select the machine work mode, which shifts from general operation mode to optional attachment operation mode.
  -  : General operation mode
  -  : Breaker operation mode (if equipped)
  -  : Crusher operation mode (if equipped)
  - Not installed : Breaker or crusher is not installed.

※ Refer to the page 4-7 for details.



### (3) User mode switch

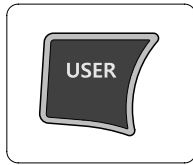

2609A3CD27

- ① This switch is used to memorize the current machine operating status in the MCU and activate the memorized user mode.
  - Memory : Push more than 2 seconds.
  - Action : Push within 2 seconds.
  - Cancel : Push this switch once more within 2 seconds.
- ② Refer to the page 3-15 for another set of user mode.

### (4) Select switch

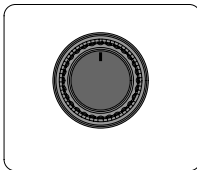

21093CD45E

- ① This switch is used to select or change the menu and input value.
- ② Knob push
  - Long (over 2 sec) : Return to the operation screen
  - Medium (0.5~2 sec) : Return to the previous screen
  - Short (below 0.5 sec) : Select menu
- ③ Knob rotation  
This knob changes menu and input value.
  - Right turning : Down direction / Increase input value
  - Left turning : Up direction / Decreased input value

### (5) Auto idle/ buzzer stop switch





2609A3CD28

- ① This switch is used to activate or cancel the auto idle function.
  - Pilot lamp ON : Auto idle function is activated.
  - Pilot lamp OFF : Auto idle function is cancelled.
- ② The buzzer sounds when the machine has a problem.  
In this case, push this switch and buzzer stops, but the warning lamp blinks until the problem is cleared.

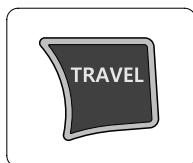
### (6) Travel speed control switch



2609A3CD29

- ① This switch is used to select the travel speed alternatively.
  -  : Low speed
  -  : High speed

### (7) Escape/Camera switch

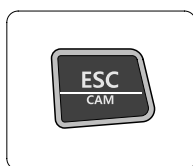

2609A3CD30

- ① This switch is used to return to the previous menu or parent menu.
- ② In the operation screen, pushing this switch will display the view of the camera on the machine (if equipped).  
Please refer to page 3-25 for the camera.
- ③ If the camera is not installed, this switch is used only ESC function.

## 6) MAIN MENU

※ You can select or set the menu by the select switch or touch screen (M).

On the operation screen, tap M to access the main menu screen.

On the sub menu screen, you can tap the menu bar to access functions or applications



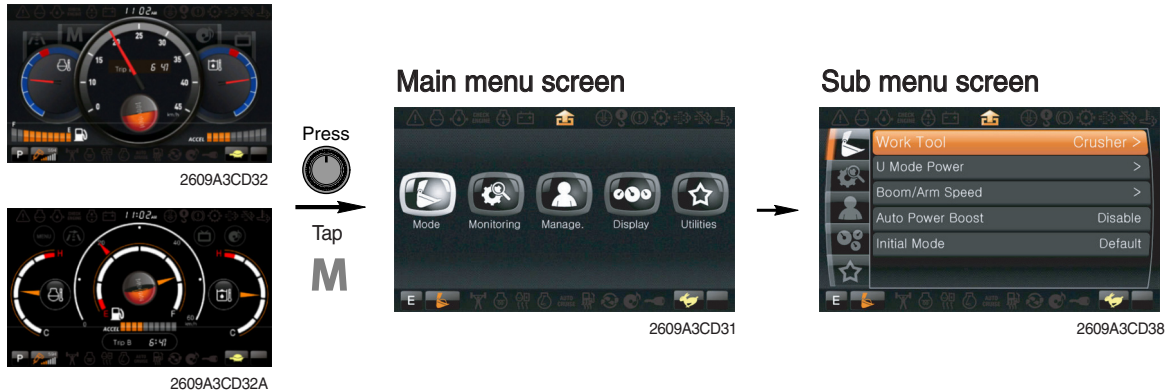

To return to the parent menu screen, tap the top menu bar. To return to operation screen, tap (🏠) icon.

· Operation screen



※ Please refer to select switch, page 3-13 for selection and change of menu and input value.

### (1) Structure

No	Main menu	Sub menu	Description
1	 Mode 2609A3CD33	Work tool U mode power Boom/Arm speed Auto power boost Initial mode	Breaker, Crusher, Not installed User mode only Boom speed, Arm speed Enable, Disable Default, U mode, P mode
2	 Monitoring 2609A3CD34	Active fault Logged fault Delete logged fault Monitoring (analog) Monitoring (digital) Operating hours	MCU, Engine ECM MCU, Engine ECM All logged fault delete, Initialization canceled Machine information Switch status, Output status Operating hours for each mode
3	 Management 2609A3CD35	Maintenance information Machine security Machine Information A/S phone number Service menu  Clinometer	Replacement, Change interval oils and filters ESL mode setting, Password change Cluster, MCU, Engine, Machine A/S phone number, A/S phone number change Power shift, Hourmeter, Replacement history, Lock lever, Upgrade, EPPR current level Clinometer setting
4	 Display 2609A3CD36	Display item Clock Brightness, Touch calibration Unit setup Language selection Screen type	Engine speed, Tripmeter A, Tripmeter B, Tripmeter C Clock Manual, Auto, Calibrating the touch screen Temperature, Pressure, Flow, Distance, Date format Korean, English, Chinese A type, B type
5	 Utilities 2609A3CD37	Entertainment Tripmeter Camera FMT DMB	Play MP4, codec. 3 kinds (A, B, C) Number of active, Display order, Camera No. FMT setting DMB select, DAB select, Channel scan, Exit

## (2) Mode setup

### ① Work tool

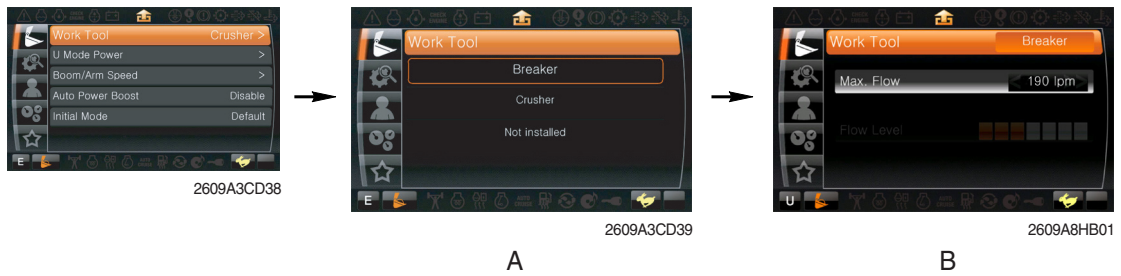

- A : Select one installed optional attachment.
- B : Max flow - Set the maximum flow for the attachment.  
 Flow level - Reduce the operating flow from maximum flow.  
 Breaker - Max 7 steps, Reduced 10 lpm each step.  
 Crusher - Max 4 steps, Reduced 20 lpm each step.

※ The flow level is displayed with the work mode pilot lamp.

### ② U mode power



- Engine high idle rpm, auto idle rpm and pump torque (power shift) can be modulated and memorized separately in U-mode.
- U-mode can be activated by user mode switch.

Step (█)	Engine speed (rpm)	Idle speed (rpm)	Power shift (bar)
1	1300	700	0
2	1400	800	3
3	1500	One touch decel low idle (900)	6
4	1600	950	9
5	1650	Auto decel rpm (1000)	12
6	1700	1050	16
7	1750	1100	20
8	1800	1150	26
9	1850	1200	32
10	1900	1250	38

### ③ Boom/Arm speed



- **Boom speed**
  - Control type  
 Manual - Boom up speed is fixed as set steps.  
 Auto - Boom up speed is automatically adjusted as working conditions by the MCU.
  - Speed setting - Boom up speed is increased as much as activated steps.
- **Arm speed**
  - Regeneration - Arm regeneration function can be activated or cancelled.  
 Enable - Arm in speed is up.  
 Disable - Fine operation.

#### ④ Auto power boost

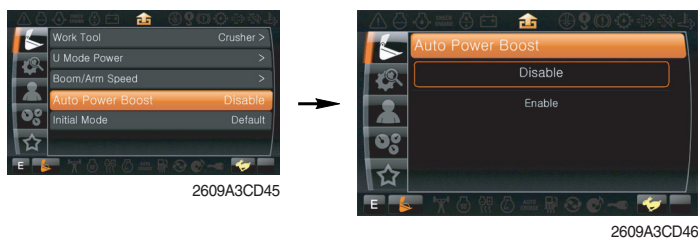

- The power boost function can be activated or cancelled.
- Enable - The digging power is automatically increased as working conditions by the MCU. It is operated max 8 seconds.
- Disable - Not operated.

#### ⑤ Initial mode

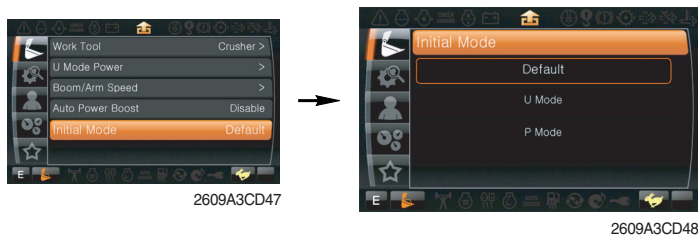

- Default - The initial power mode is set E mode when the engine is started.
- U mode - The initial power mode is set U mode when the engine is started.

### (3) Monitoring

#### ① Active fault



- The active faults of the MCU or engine ECM can be checked by this menu.

#### ② Logged fault



- The logged faults of the MCU or engine ECM can be checked by this menu.

### ③ Delete logged fault

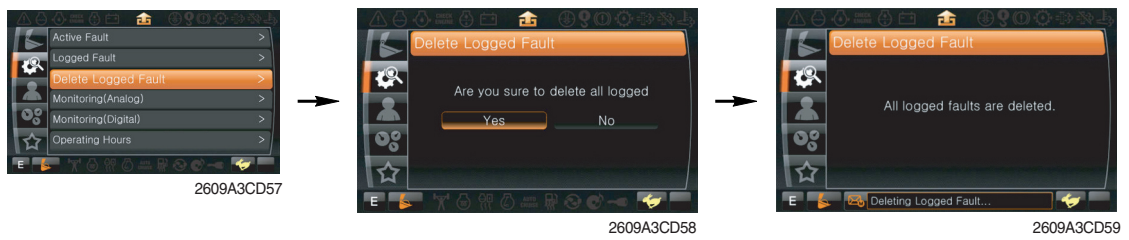

- The logged faults of the MCU or engine ECM can be deleted by this menu.

### ④ Monitoring(Analog)



- The machine status such as the engine rpm, oil temperature, voltage and pressure etc. can be checked by this menu.

### ⑤ Monitoring (digital)

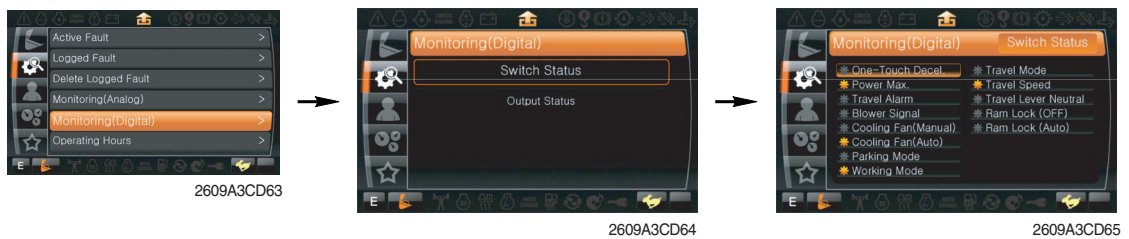

- The switch status or output status can be confirmed by this menu.
- The activated switch or output pilot lamps are light ON.

### ⑥ Operating hours



- The operating hour of each mode can be confirmed by this menu.

#### (4) Management

##### ① Maintenance information



- Alarm (⚙️ 🟡 🔴) : Gray ⚙️ - Normal  
Yellow 🟡 - First warning  
Red 🔴 - Second warning
- Replacement : The elapsed time will be reset to zero (0).
- Change interval : The change or replace interval can be changed in the unit of 50 hours.
- OK : Return to the item list screen.
- **Change or relpace interval**

No	Item	Interval
1	Engine oil	500
2	Final gear oil	1000
3	Swing gear oil	1000
4	Hydraulic oil	5000
5	Pilot line filter	1000
6	Drain filter	1000
7	Hydraulic oil return filter	1000
8	Engine oil filter	500
9	Fuel filter	500
10	Pre-filter	500
11	Hydraulic tank breather	250
12	Air cleaner (inner & outer)	4000
13	Radiator coolant	2000
14	Swing gear pinion grease	1000

## ② Machine security



### · ESL mode setting

- ESL : Engine Starting Limit
- ESL mode is designed to be a theft deterrent or will prevent the unauthorized operation of the machine.
- If the ESL mode was selected Enable, the password will be required when the start switch is turned ON.

### - Machine security

Disable : Not used ESL function

Enable (always) : The password is required whenever the operator starts engine.

- **Interval** : The password is required when the operator starts engine first. But the operator can restart the engine within the interval time without inputting the password.

The interval time can be set maximum 4 hours.

※ Default password : 00000 \*

※ Password length : (5~10 digit) + \*



- **Smart key (option)** : Smart key is registered when the operator starts engine by start button first. If smart key is not inside of the cabin, authentication process fails and the password entering is needed.

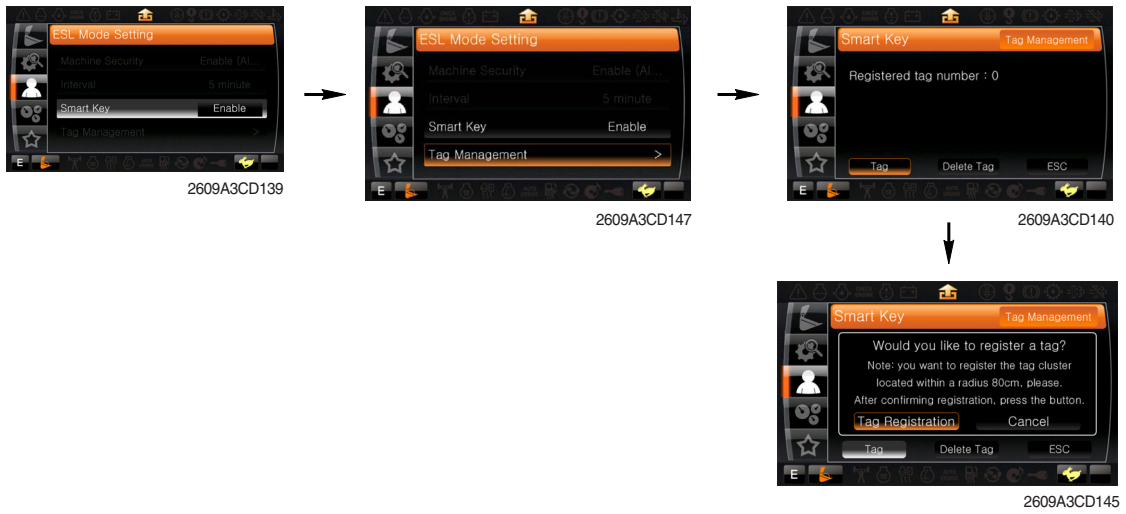

· **Password change**

- The password is 5~10 digits.

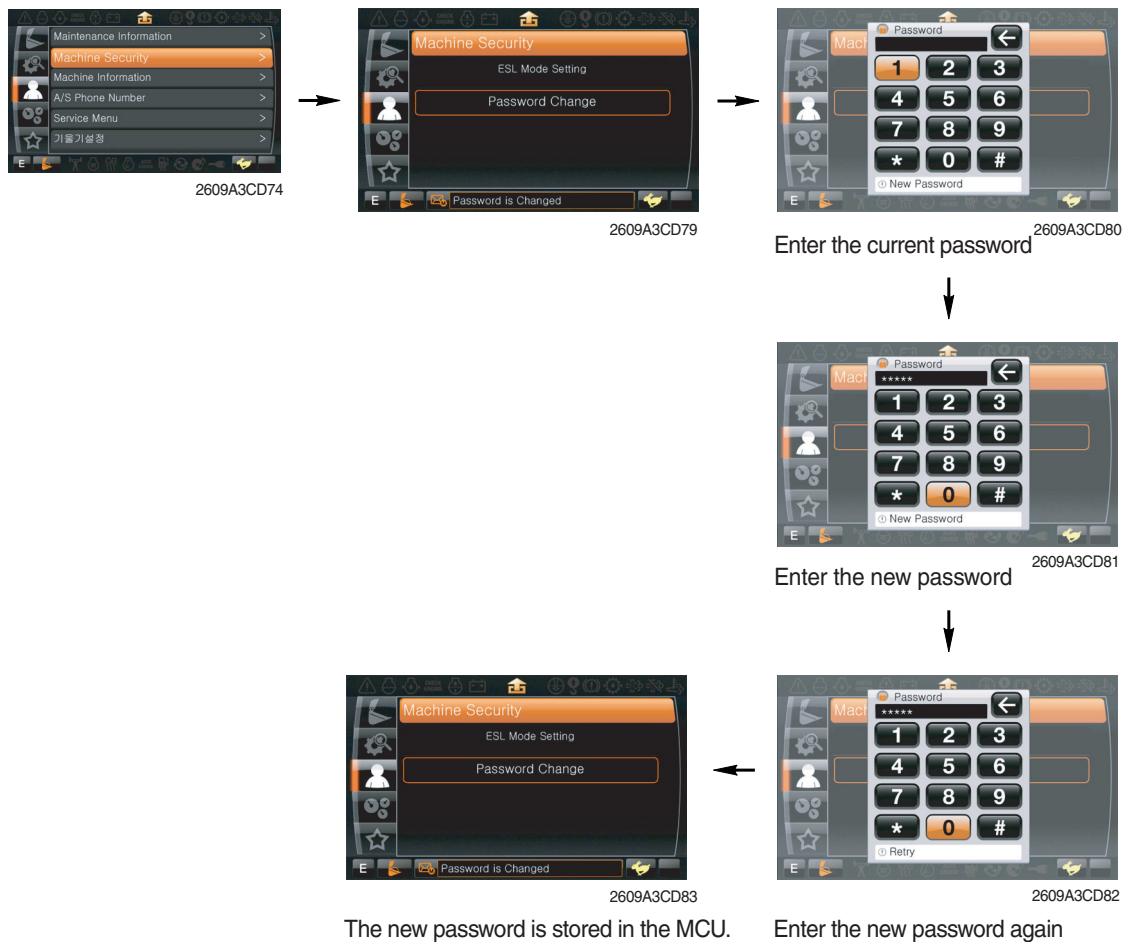



### ③ Machine Information

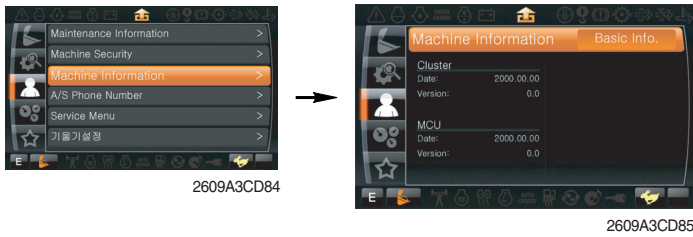

- This can confirm the identification of the cluster, MCU, engine and machine.

### ④ A/S phone number

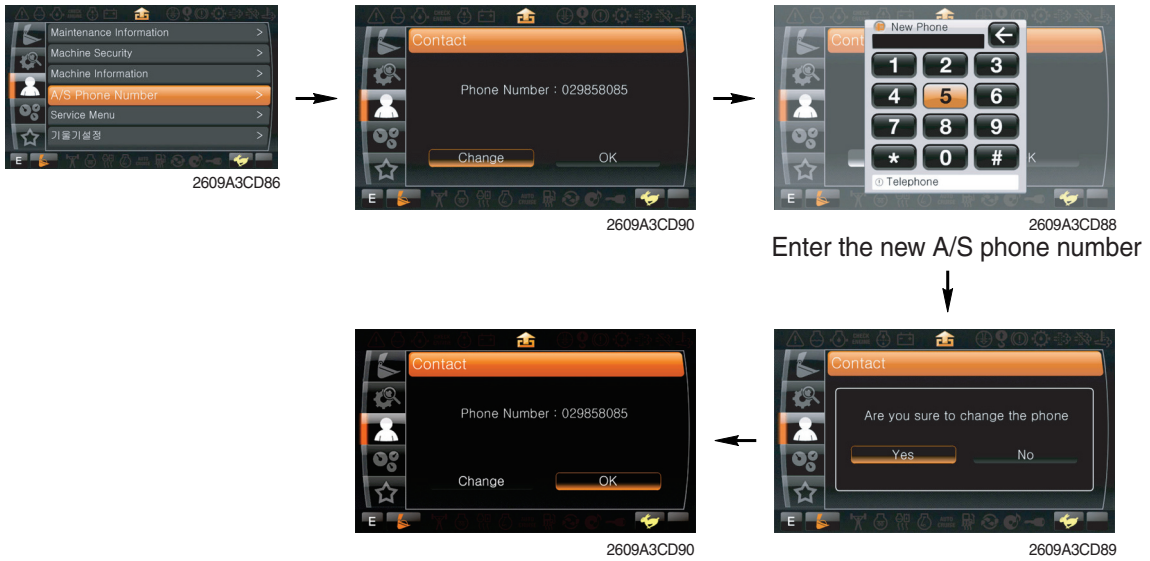

Enter the new A/S phone number

The new phone number is stored in MCU

### ⑤ Service menu

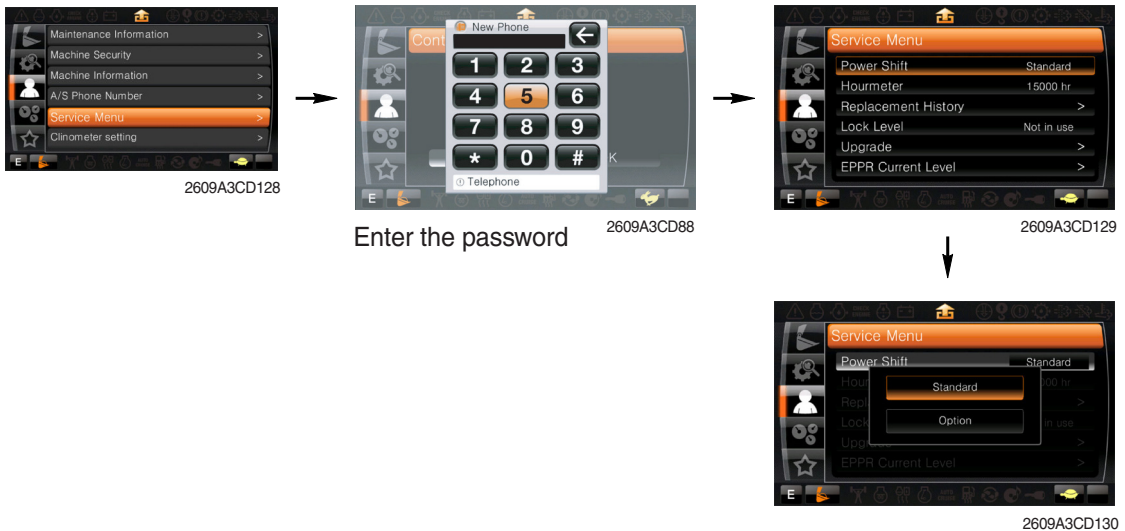

Enter the password

- Power shift (standard/option) : Power shift pressure can be set by option menu.
- Hourmeter : Operating hours since the machine line out can be checked by this menu.
- Replacement history : Replacement history of the MCU and cluster can be checked by this menu.
- Lock level (not in use/in use)
- Upgrade : Firm ware can be upgraded by this menu. (the USB port is located under the cluster)
- EPPR current level (attach EPPR/boom priority EPPR)

## ⑥ Clinometer

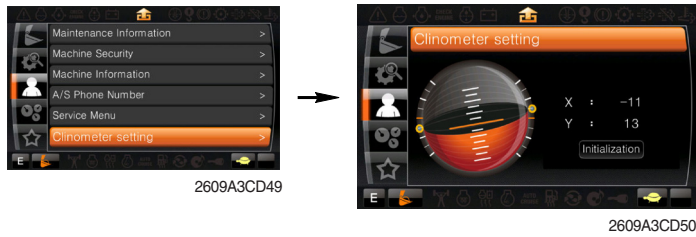

- When the machine is on the flatland, if tap the "initialization", the values of X, Y reset "0".
- You can confirm tilt of machine in cluster's operating screen.

## (5) Display

### ① Display item



- The center display type of the LCD can be selected by this menu.
- The engine speed or each of the tripmeter (A,B,C) is displayed on the center display.

### ② Clock



- The first line's three spots "\*\*/\*\*/\*\*\*\*" represent Month/Day/Year each.
- The second line shows the current time. (0:00~23:59)

### ③ Brightness and touch calibration

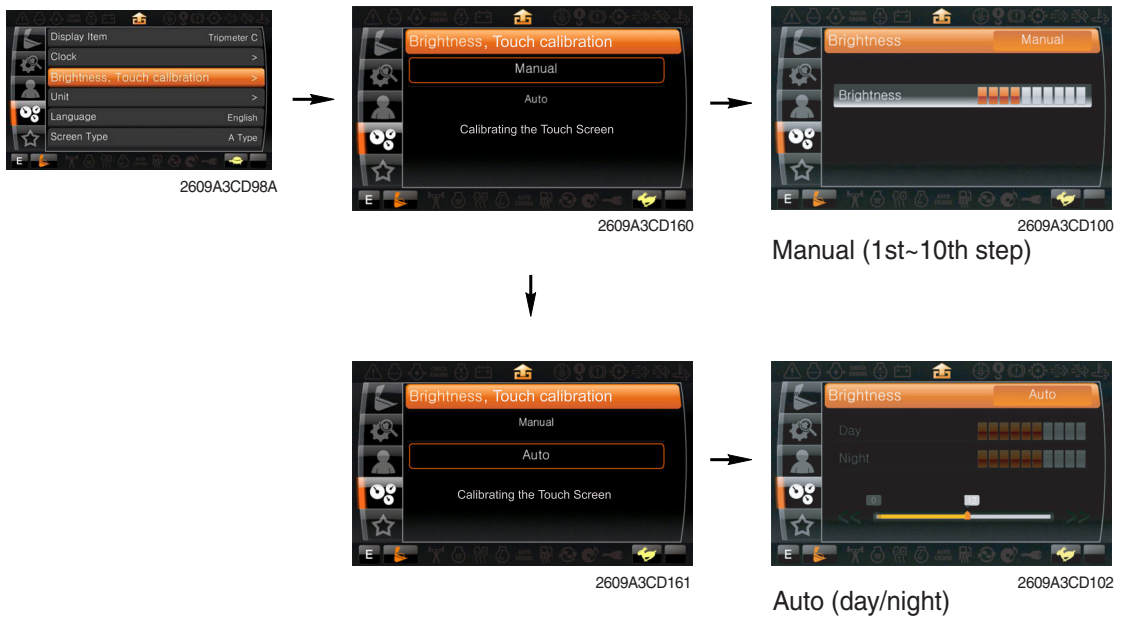

- If "Auto" is chosen, brightness for day and night can be differently set up. Also by using the bar in lower side, users can define which time interval belongs to day and night. (in bar figure, white area represents night time while orange shows day time)
- **Touch calibration** - When touch awareness goes wrong, this function use.  
Fall in the next step if touches the middle point of cross with fingernail.  
If touches total five points as follows, the setting is completed.

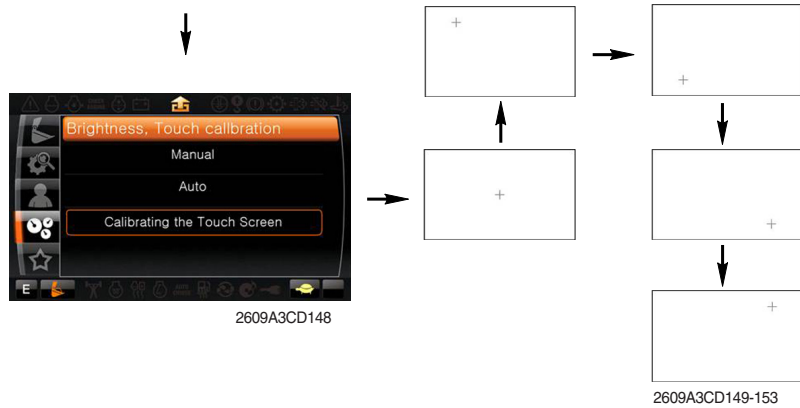

### ④ Unit



- Temperature : °C ↔ °F
- Pressure : bar ↔ MPa ↔ kgf/cm<sup>2</sup>
- Flow : lpm ↔ gpm
- Date format : yy/mm/dd ↔ mm/dd/yy ↔ dd-Mar-yy

## ⑤ Language



- User can select preferable language and all displays are changed the selected language.

## ⑥ Screen type

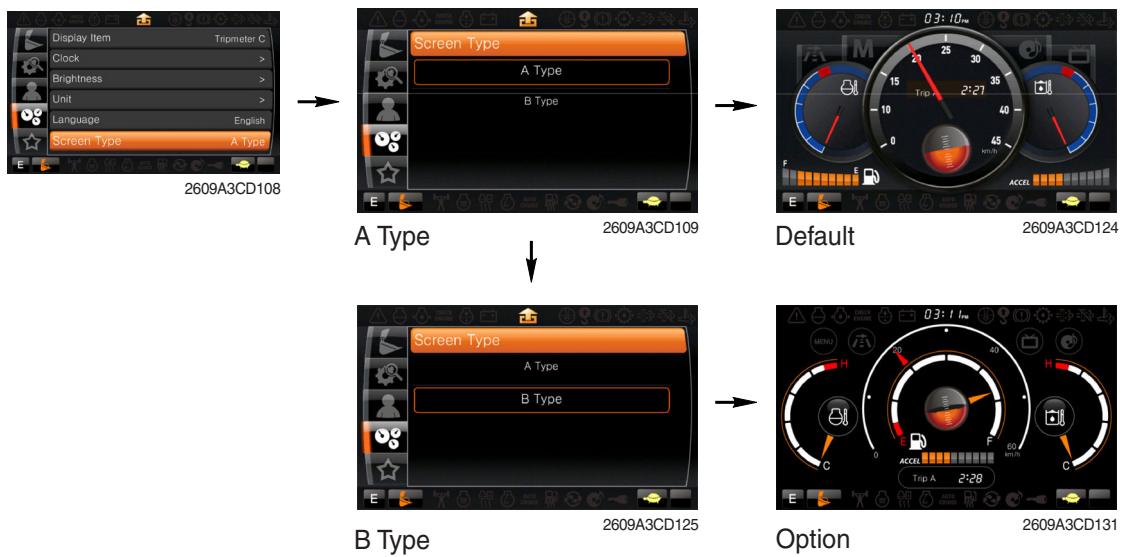

## (6) Utilities

### ① Entertainment

- Play MP4 or codec file of external hard disk through USB port.
- The USB port is located under the cluster.



- Over 1100 engine rpm, the screen turns into the operation screen with MP4 or codec file playing for the safety.

## ② Tripmeter



- Maximum 3 kinds of tripmeters can be used at the same time.
- Each tripmeter can be turned on by choosing "Start" while it also can be turned off by choosing "Stop".
- If the tripmeter icon is activated in the operation screen, it can be controlled directly there.

## ③ Camera setting

- Three cameras can be installed on the machine and the display order can be set by this menu.
- If the camera was not equipped, this menu is not useful.



- Turning the select switch in clockwise direction, the next ordered will be shown and in counter-clockwise direction, the previously ordered will be shown.
- Push the select switch, the displayed screen will be enlargement.



#### ④ FMT setting

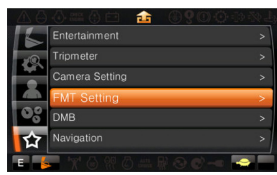

2609A3CD121



2609A3CD154



2609A3CD155



2609A3CD156

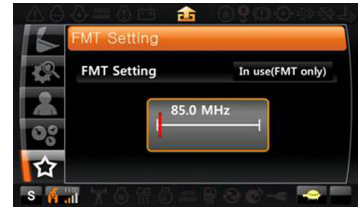

2609A3CD157



2609A3CD158

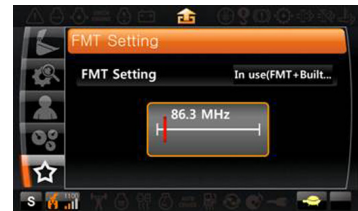

2609A3CD159

- The function that can listen cluster's occurrence sound by inside speaker of cabin making frequency of audio identical in cluster's frequency and machine.
- Turn on the FMT function and sets frequency equally with frequency of audio in cabin.
  - Not in use : Cluster speaker only
  - In use (FMT only) : Cabin speaker only
  - In use (FMT+Built) : Cabin speaker + Cluster speaker

#### ⑤ DMB (option)

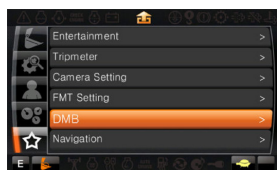

2609A3CD112



2609A3CD113

### 3. SWITCHES

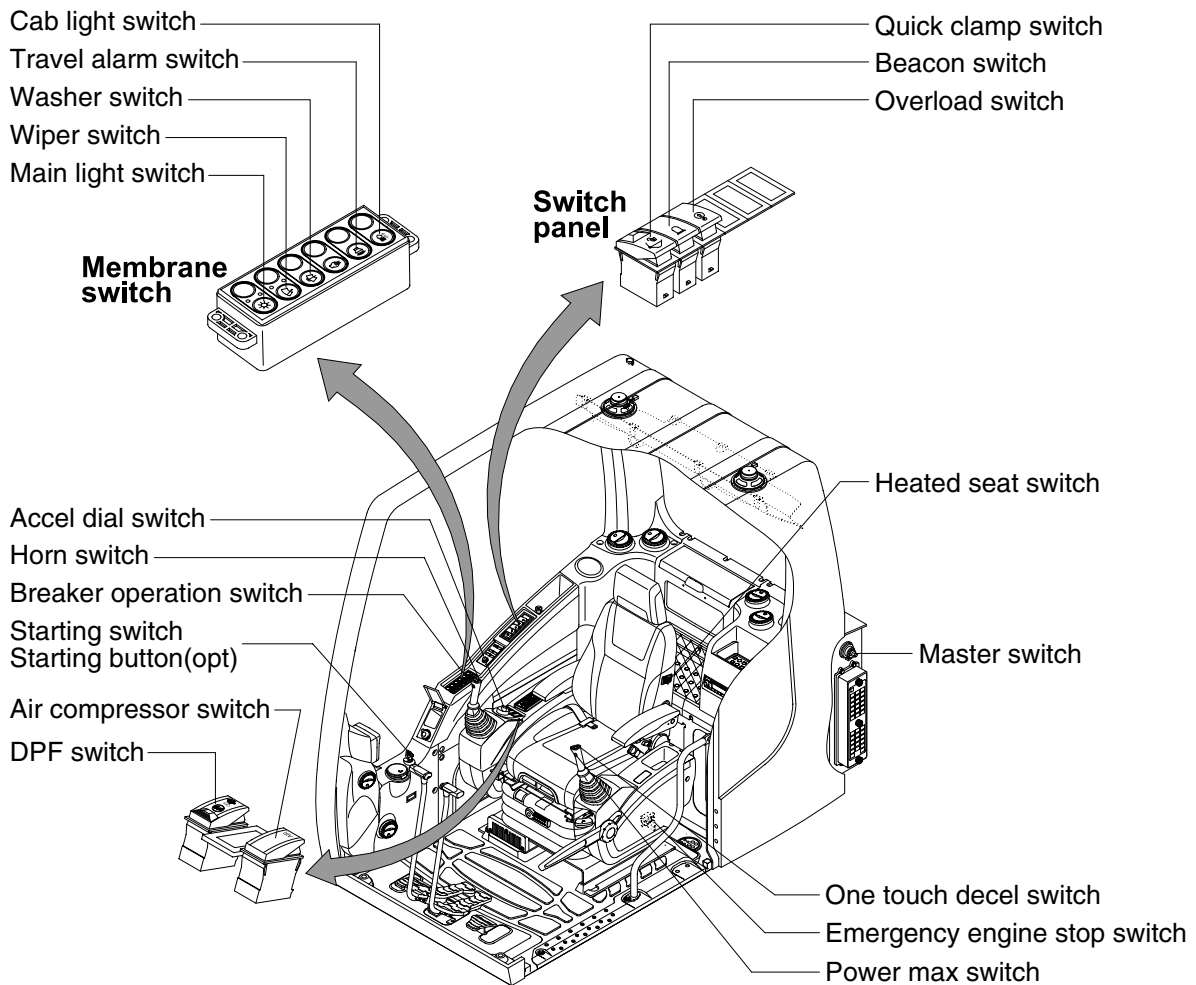

2609A3CD02

#### 1) STARTING SWITCH & STARTING BUTTON (OPT)

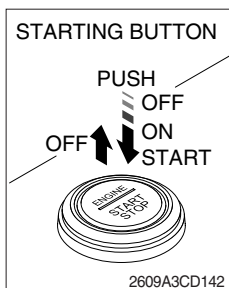
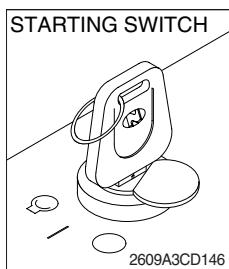

Starting button with smart key tag (opt)

(1) There are three positions, OFF, ON and START.

- ○ (OFF) : None of electrical circuits activate.
- | (ON) : All the systems of machine operate.
- Ⓚ (START) : Use when starting the engine.

Release key immediately after starting.

- ※ If you turn ON the starting switch in cold weather, the fuel warmer is automatically operated to heat the fuel by sensing the coolant temperature. Start the engine in 1~2 minutes after turning ON the starting switch. More time may take according to ambient temperature.
- ※ Key must be in the ON position with engine running to maintain electrical and hydraulic function and prevent serious machine damage.

## 2) MASTER SWITCH

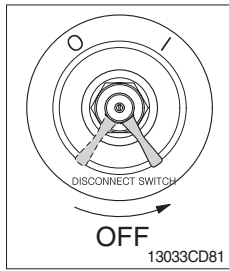

- (1) This switch is used to shut off the entire electrical system.
  - (2) I : The battery remains connected to the electrical system.  
O : The battery is disconnected to the electrical system.
- ※ **Never turn the master switch to O (OFF) with the engine running. Engine and electrical system damage could result.**

## 3) ACCEL DIAL SWITCH

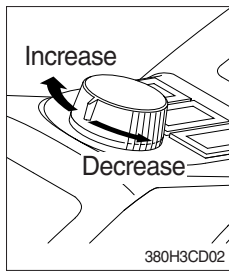

- (1) There are 10 dial setting.
- (2) Setting 1 is low idle and setting 10 is high idle.
  - By rotating the accel dial to right : Engine speed increases
  - By rotating the accel dial to left : Engine speed decreases

## 4) MAIN LIGHT SWITCH

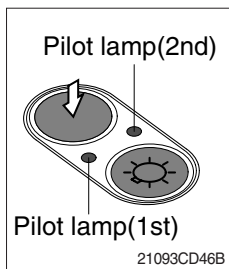

- (1) This switch used to operate the head light and work light.
  - Press the switch once, the head light comes ON and the 1st pilot lamp ON.
  - Press the switch once more, the work light comes ON and the 2nd pilot lamp ON.
  - Press the switch again, return to a first step position.
  - Press the switch more than one second to turn off lights.

## 5) WIPER SWITCH

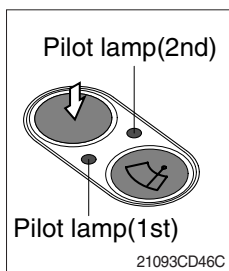

- (1) This switch used to operate wiper.
  - Press the switch once the wiper operates intermittently and the 1st pilot lamp comes ON.
  - Press the switch once more, the wiper operates low speed and the 2nd pilot lamp comes ON.
  - Press the switch again return to a first step position.
  - Press the switch more than one second to turn off wiper.

## 6) WASHER SWITCH

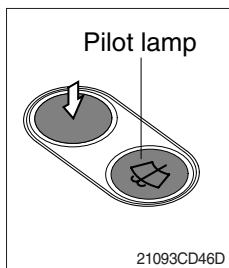

- (1) The washer liquid is sprayed and the wiper is operated only while pressing this switch.
- (2) The pilot lamp is turned ON when operating this switch.



## 7) TRAVEL ALARM SWITCH

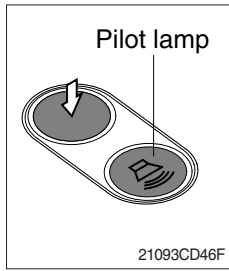

- (1) This switch is to activate travel alarm function surrounding when the machine travels to forward and backward.
- (2) On pressing this switch, the alarm operates only when the machine is traveling.

## 8) CAB LIGHT SWITCH (option)

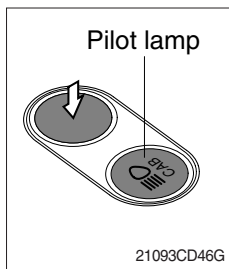

- (1) This switch turns ON the cab light on the cab.

## 9) OVERLOAD SWITCH (option)

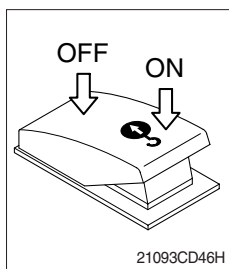

- (1) When this switch turned ON, buzzer makes sound and overload warning lamp comes ON in case that the machine is overload.
- (2) When it turned OFF, buzzer stops and warning lamp goes out.

## 10) QUICK CLAMP SWITCH (option)

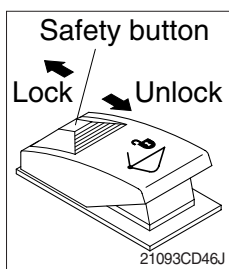

- (1) This switch is used to engage or disengage the moving hook on quick clamp.
- ※ Refer to the page 8-6 for details.

## 11) BEACON SWITCH (option)

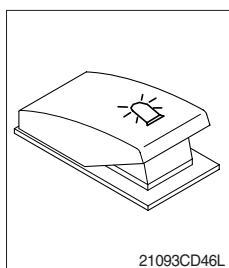

- (1) This switch turns ON the rotary light on the cab.
- (2) The indicator lamp is turned ON when operating this switch.

## 12) HEATED SEAT SWITCH (option)

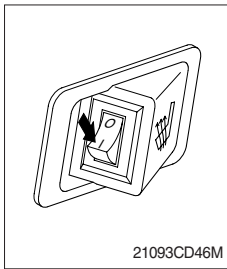

- (1) This switch is used to heat the seat.
  - Heater ON :  $10 \pm 3.5^{\circ}\text{C}$
  - Heater OFF :  $20 \pm 3^{\circ}\text{C}$
- (2) On pressing the switch, the indicator lamp is turned ON.

## 13) HORN SWITCH

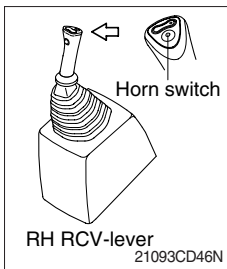

- (1) This switch is at the top of right side control lever.  
On pressing, the horn sounds.

## 14) BREAKER OPERATION SWITCH

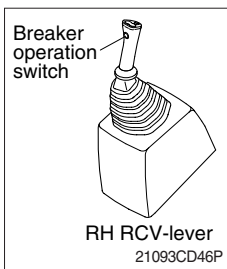

- (1) On pressing this switch, the breaker operates only when the breaker operation mode is selected.

## 15) ONE TOUCH DECEL SWITCH

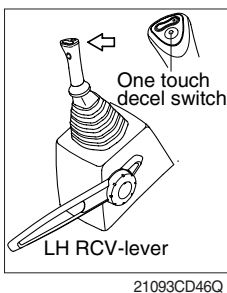

- (1) This switch is used to actuate the deceleration function quickly.
- (2) The engine speed is increased to previous setting value by pressing the switch again.
- (3) One touch decel function is available only when the auto idle pilot lamp is turned OFF.

## 16) POWER MAX SWITCH

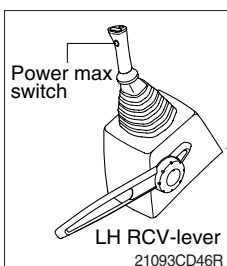

- (1) This switch activate power max function.  
When this switch is kept pressed, hydraulic power of work equipment will be increased to approx 110 percent during 8 seconds.
  - (2) After 8 seconds, function is cancelled automatically even the switch keeps pressed.
- ※ Do not use for craning purposes.

### 17) AIR COMPRESSOR SWITCH (option)

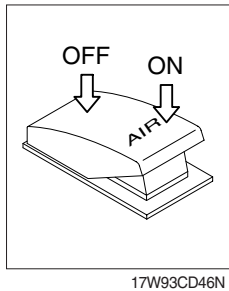

- (1) This switch is used to activate the air compressor.
- (2) The indicator lamp is turned on when operating this switch.

### 18) EMERGENCY ENGINE STOP SWITCH

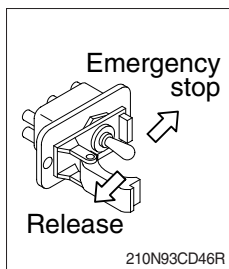

- (1) This switch is used to emergency stop the engine.
- ※ **Be sure to keep the emergency switch on the release position when restart the engine.**

### 19) DPF (diesel particulate filter) SWITCH

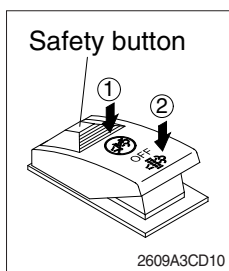

- (1) This switch is used to select the regeneration function of the DPF.
- (2) Inhibit position (①)**
- ① The inhibit position disallows any automatic or manual regeneration of the DPF.
  - ② This may be used by operator to prevent regeneration when the machine is operating in a hazardous environment is concerned about high temperature.
  - ③ It is strongly recommended that the this position is only activated when high temperatures may cause a hazardous condition.
- (3) OFF position**
- This position will initiate a automatic regeneration of the DPF.
- (4) Manual regeneration position (②)**
- ① This position will only initiate a manual regeneration of the DPF when the machine is in non-mission condition, engine must run at low idle speed and DPF soot levels are high enough to allow regeneration.
  - ② HEST lamp will be illuminated during the entire regeneration.
- ※ **Refer to the page 3-7 for details.**
- ※ **This switch can be move to the manual regeneration position (②) only when the safety button is pulled to backward.**
- ※ **Also, this switch return to the OFF position when released the manual regeneration position (②).**

## 4. LEVERS AND PEDALS

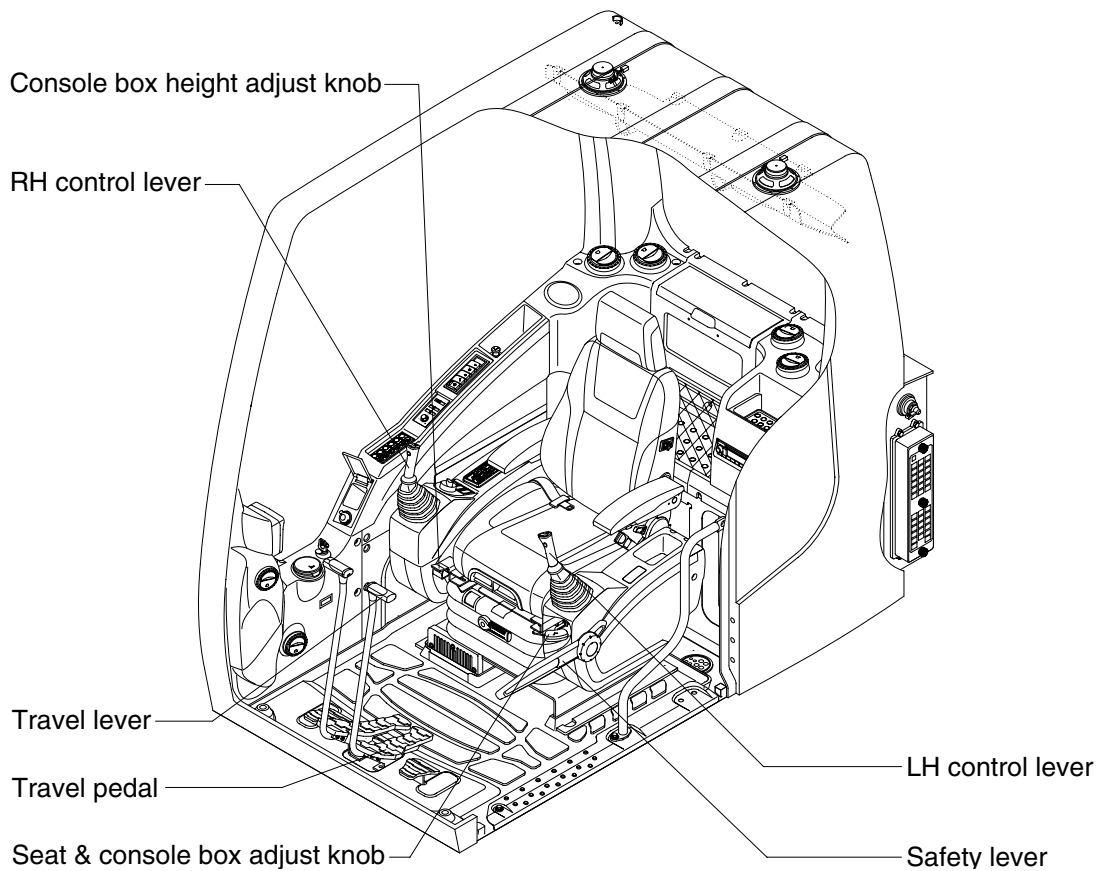

2609A3CD03

### 1) LH CONTROL LEVER

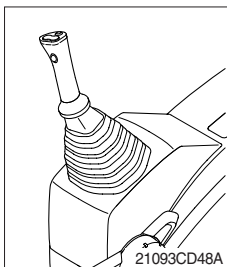

- (1) This joystick is used to control the swing and the arm.
- (2) Refer to operation of working device in chapter 4 for details.

### 2) RH CONTROL LEVER

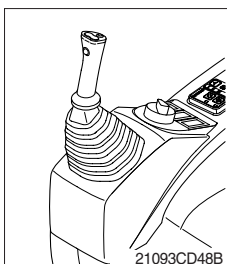

- (1) This joystick is used to control the boom and the bucket.
- (2) Refer to operation of working device in chapter 4 for details.

### 3) SAFETY LEVER

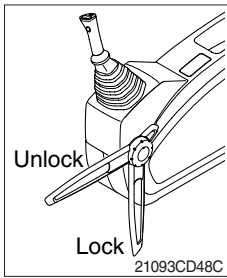

- (1) All control levers and pedals are disabled from operation by locating the lever to lock position as shown.
  - ※ **Be sure to lower the lever to LOCK position when leaving from operator's seat.**
- (2) By pull lever to UNLOCK position, the machine is operational.
  - ※ **Do not use the safety lever for handle when getting on or off the machine.**

### 4) TRAVEL LEVER

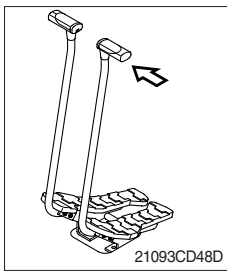

- (1) This lever is mounted on travel pedal and used for traveling by hand. The operation principle is same as the travel pedal.
- (2) Refer to traveling of the machine in chapter 4 for details.

### 5) TRAVEL PEDAL

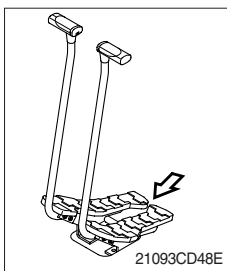

- (1) This pedal is used to move the machine forward or backward.
- (2) If left side pedal is pressed, left track will move.  
If right side pedal is pressed, right track will move.
- (3) Refer to traveling of machine in chapter 4 for details.

### 6) SEAT AND CONSOLE BOX ADJUST KNOB

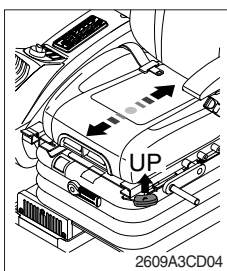

- (1) This knob is used to move the seat and console box to fit the contours of the operator's body.
- (2) Pull the knob to adjust forward or backward over 150 mm (5.9").

### 7) CONSOLE BOX HEIGHT ADJUST KNOB

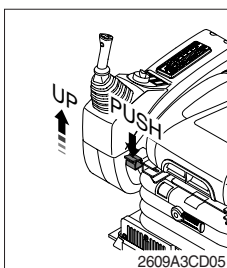

- (1) This knob is used to move the LH and RH control lever to fit the contours of the operator's body.
- (2) The control lever can be moved upward and downward over 60 mm (2.4").

## 5. AIR CONDITIONER AND HEATER

Full auto air conditioner and heater system automatically keeps the optimum condition in accordance with operator's temperature configuration sensing ambient and cabin inside temperature.

- Location of air flow ducts

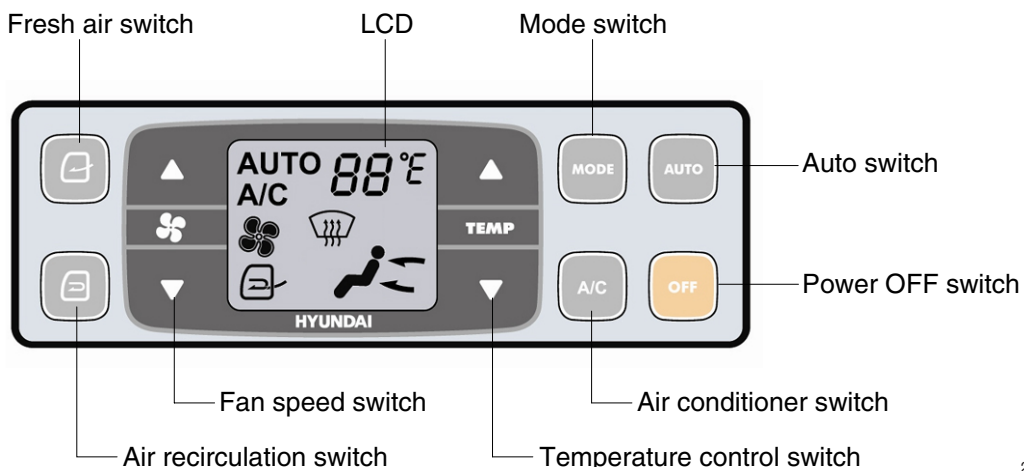
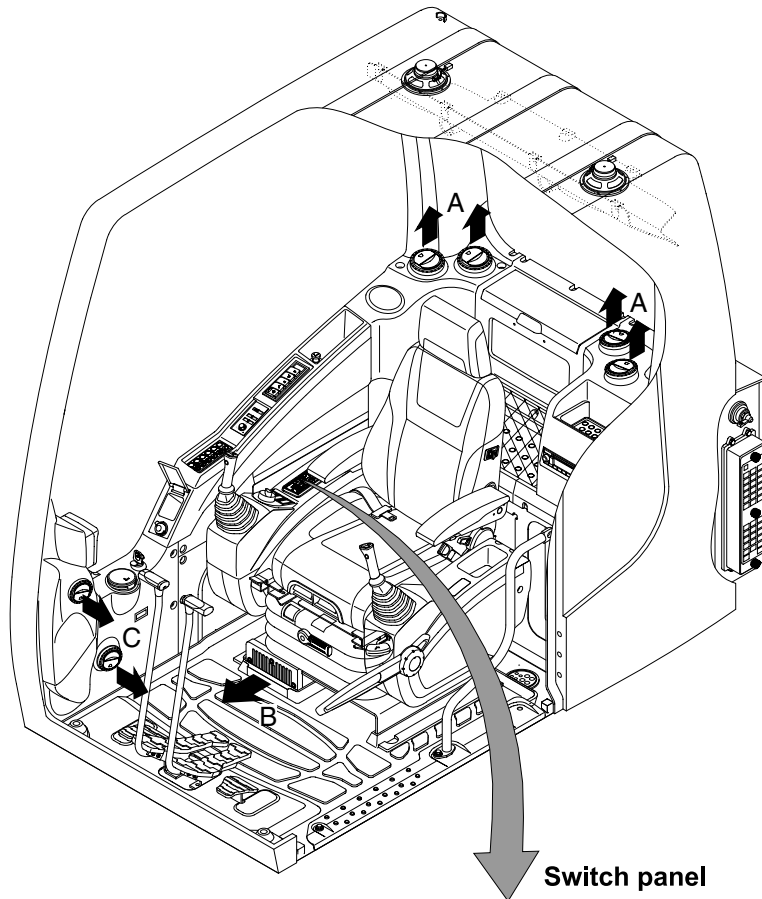

2609A3CD06

## 1) POWER OFF SWITCH

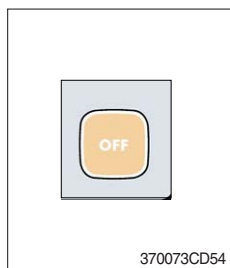

- (1) This switch makes the system and the LED OFF.  
Just before the power OFF, set values are stored.

### (2) Default setting values

Function	Air conditioner	In/outlet	LCD	Temperature	Mode
Value	OFF	Inlet	OFF	Previous sw OFF	Previous sw OFF

## 2) AUTO SWITCH

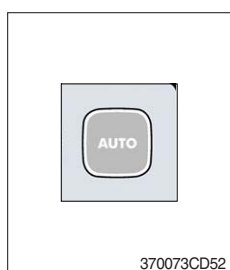

- (1) Turn the starting switch to ON position, LCD lights ON.  
Auto air conditioner and heater system automatically keeps the optimum condition in accordance with operator's temperature configuration sensing ambient and cabin inside temperature.
- (2) This switch can restart system after system OFF.

## 3) AIR CONDITIONER SWITCH (compressor switch)

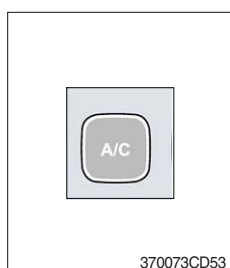

- (1) This switch turns the compressor and the LCD ON.
- (2) In accordance with the temperature sensed by duct (evaporator) sensor, compressor turns ON or OFF automatically.
- ※ **Air conditioner operates to remove vapor and drains water through a drain hose. Water can be sprayed into the cab in case that the drain cock at the ending point of drain hose has a problem.**  
**In this case, exchange the drain cock.**

## 4) FAN SPEED SWITCH

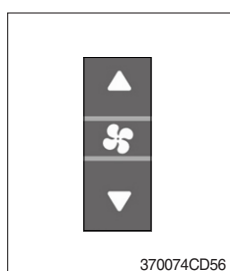

- (1) Fan speed is controlled automatically by set temperature.
- (2) This switch controls fan speed manually.
- There are 8 up/down steps to control fan speed.
  - The maximum step or the minimum step beeps 5 times.
- (3) This switch makes the system ON.

## 5) TEMPERATURE CONTROL SWITCH

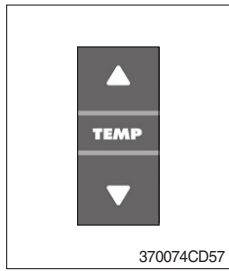

(1) Setting temperature indication

- ① Type A : 17~32°C, scale : 1°C
- ② Type B : Lo, 18~31°C, Hi, scale : 1°C

(2) Max cool and max warm beeps 5 times.

(3) The max cool or the max warm position operates as following table.

Temperature	Compressor	Fan speed	In/Outlet	Mode
Max cool	ON	Max (Hi)	Recirculation	Vent
Max warm	OFF	Max (Hi)	Fresh	Foot

(4) Temperature unit can be changed between celsius (°C) and fahrenheit (°F)

- ① Default status (°C)
- ② Push Up/Down temperature control switch simultaneously more than 5 second displayed temperature unit change (°C → °F)

## 6) MODE SWITCH

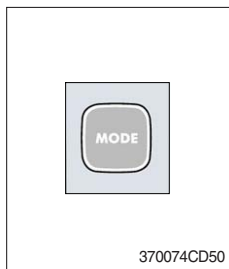

(1) Operating this switch, it beeps and displays symbol of each mode in order. (Vent → Vent/Foot → Def/Foot → Def/Vent → Def/Vent/Foot)

Mode switch		Vent	Vent/Foot	Def/Foot	Def/Vent	Def/Vent/Foot
Outlet	A	●	●		●	●
	B		●	●		●
	C			●	●	●

(2) When defroster mode operating, FRESH AIR/AIR RECIRCULATION switch turns to FRESH AIR mode and air conditioner switch turns ON.

## 7) FRESH AIR/AIR RECIRCULATION SWITCH

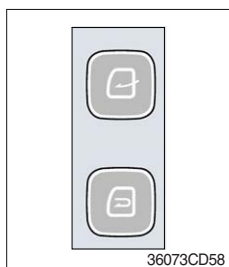

(1) It is possible to change the air-inlet method.

① **Fresh air** ( )

Inhaling air from the outside.

※ **Check out the fresh air filter periodically to keep a good efficiency.**

② **Air recirculation** ( )

It recycles the heated or cooled air to increase the energy efficiency.

※ **Change air occasionally when using recirculation for a long time.**

※ **Check out the recirculation filter periodically to keep a good efficiency.**



## 8) SELF DIAGNOSIS FUNCTION

### (1) Procedure

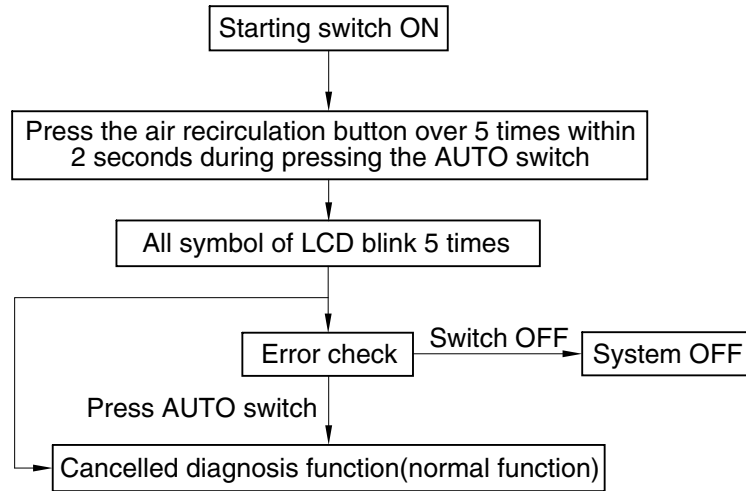

3607A3CD69

### (2) Error check

- The corresponding error code flickers on the setup temperature display panel, the other symbol will turn OFF.
- Error code flickers every 0.5 second.
- If error code is more than two, each code flickers 2 times in sequence.
- Error code

Error code	Description	Error code	Description
11	Cabin inside sensor	16	Mode actuator 1
12	Ambient sensor	17	Mode actuator 2
14	Duct (evaporator) sensor	18	Intake actuator
15	Temp actuator	-	-

### (3) Fail safe function

Error description	Fail safe function
Cabin inside sensor (11)	25°C alternate value control
Ambient sensor (12)	20°C alternate value control
Duct (evaporator) sensor (14)	1°C alternate value control
Temp actuator (15)	If opening amount is 0 %, the alternate value is 0 %
	If not, the alternate value is 100 %
Mode actuator 1, 2 (16, 17)	The alternate value is vent

## 6. OTHERS

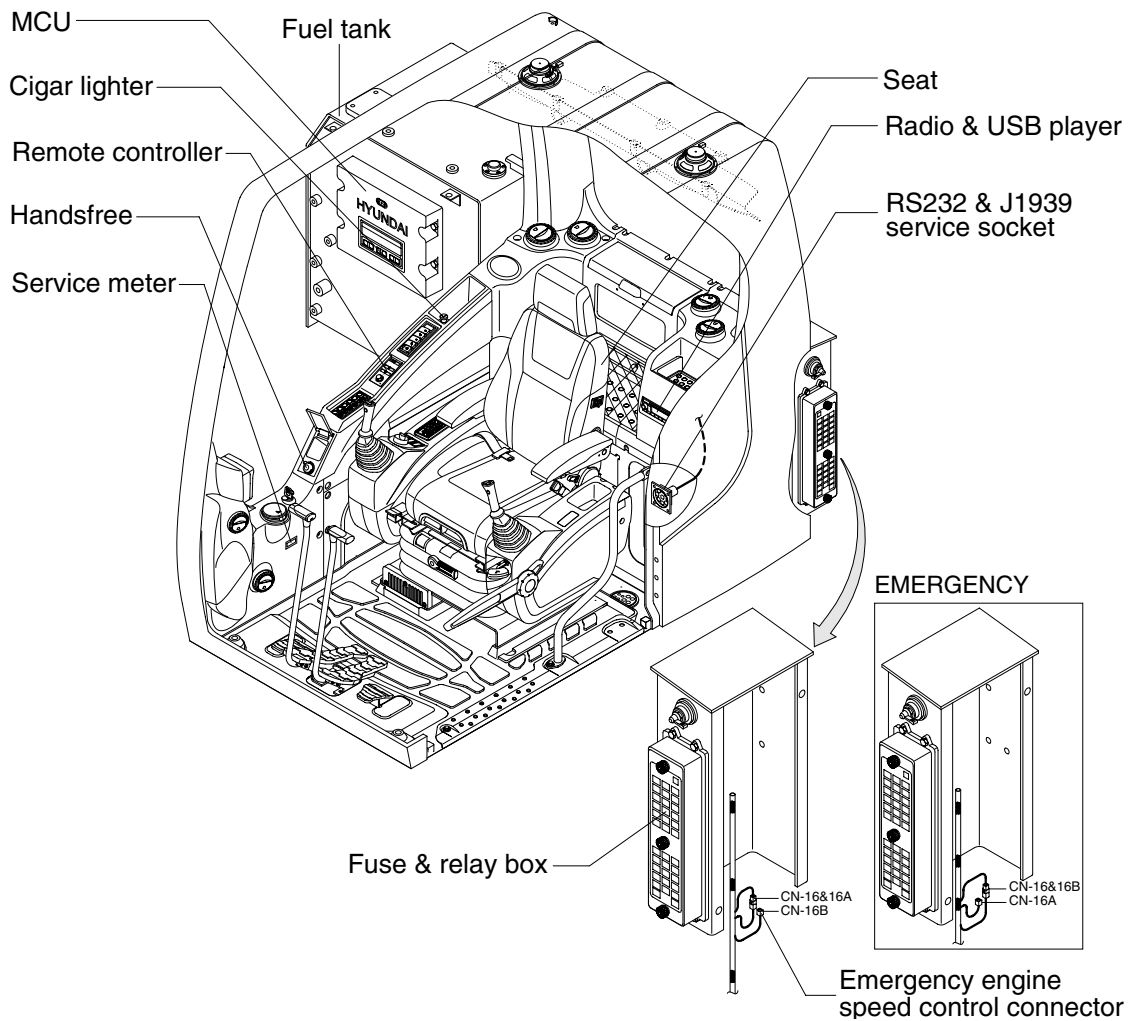

2609A3CD07

### 1) CIGAR LIGHTER

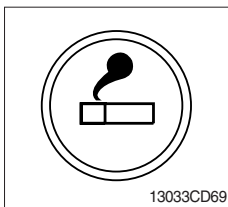

- (1) This can be used when the engine starting switch is ON.
- (2) The lighter can be used when it springs out in a short while after being pressed down.

※ **Service socket**

**Use cigar lighter socket when you need emergency power.  
Do not use the lighter exceeding 24 V, 100 W.**

## 2) HANDSFREE

Allow you to dial a call or to have a conversation without holding your handset. Use the remote controller when making and answering a calls or ring off.

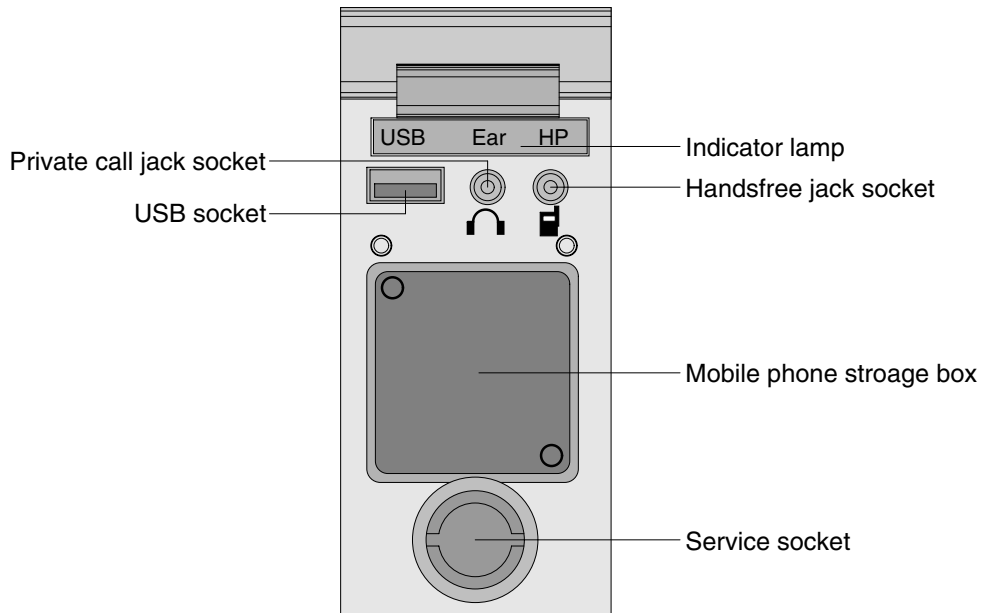

21093CD51

### (1) Mobile phone storage box

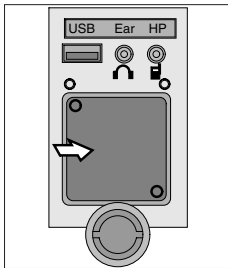

21093CD51A

- ① Mobile phone can be stored when call by handsfree.

### (2) USB socket

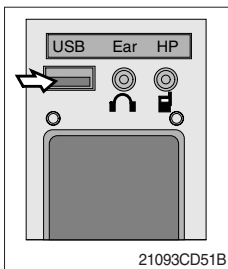

21093CD51B

- ① This socket is used to charging the mobile phone.

### (3) Private call jack socket

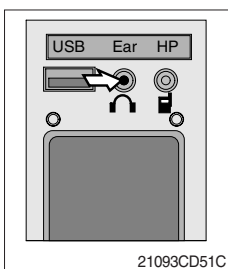

21093CD51C

- ① This can be used protect you privacy calling by using ear phone.
- ② The mobile phone must be connected handsfree jack socket.

#### (4) Handsfree jack socket

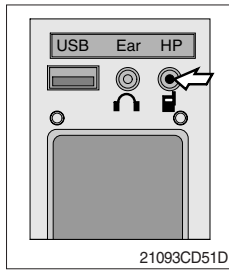

- ① Connect the jack cable when call by handsfree.
- ② Use the special adapter when jack cable is not interchangeable.
- ③ Check the jack type of mobile phone before use.

#### (5) Indicator lamp

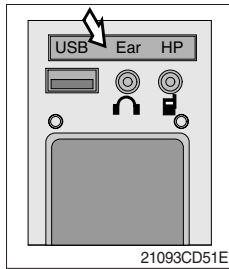

- ① This lamp is turned ON when the handsfree mode selected.

#### (6) Service socket

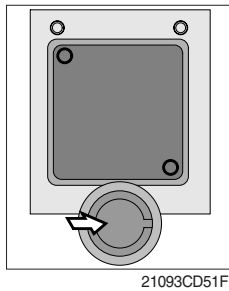

- ① Utilize the power of 12 V as your need and do not exceed power of 12 V, 30 W.

## (7) Wireless handsfree



- ① Select the handsfree mode by pressing bluetooth button on the mobile phone.

Press the **CALL** button for more than 6 seconds for pairing (connection process of the mobile phone and handsfree), you can hear beep sounds three times.

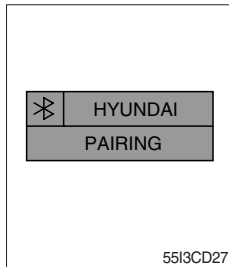

- ② The mobile phone finds bluetooth named "HYUNDAI".  
Select "HYUNDAI" and set "connect with Bluetooth on the mobile phone".  
· Default password : 0000

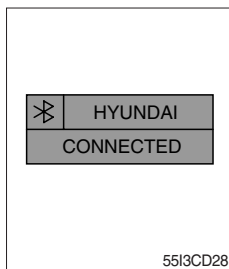

- ③ The Bluetooth pairing is made, the LCD screen shows "CONNECTED".
- ④ Once the Bluetooth pairing is made, they will be automatically connected after 20 seconds when start key ON.
- ⑤ When you want to deactivate the pairing, press and hold the **CALL** button for more than 3 seconds then you can hear beep sounds twice and the function will be deactivated.

### 3) REMOTE CONTROLLER

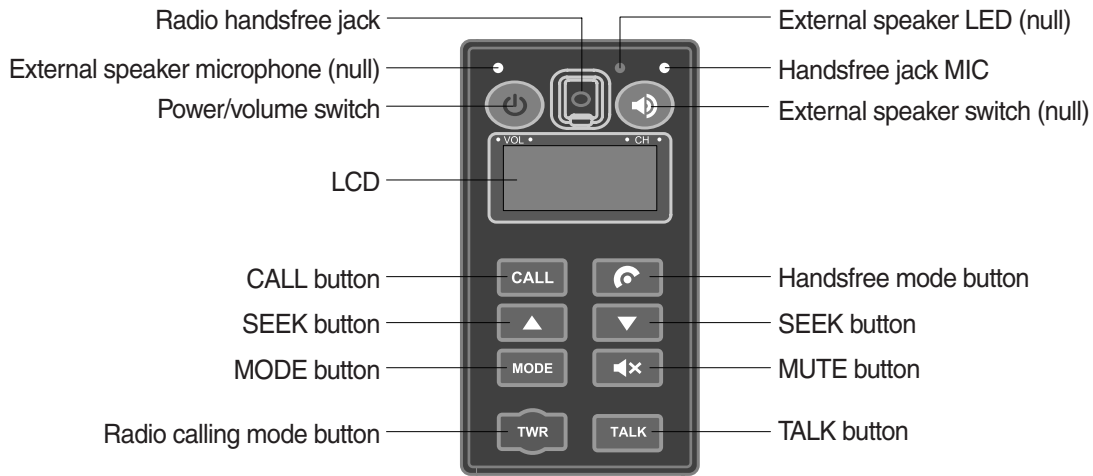

5513CD31

#### (1) Power and volume switch

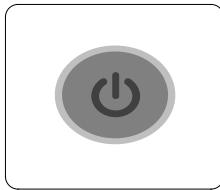

5513CD31A

- ① This switch is used to turn the audio or handsfree ON or OFF.
  - ② This switch is turned to right, the handsfree volume is increased over 7 steps.
  - ③ If it is turned to left, volume will be decreased.
- ※ **This switch adjust the audio volume when selected audio mode.**

#### (2) Mode change button

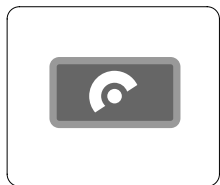

5513CD31B

- ① This button is to select the handsfree mode or audio mode.
  - Lamp ON : Handsfree mode ("TEL MUTE" displayed ON audio LCD)
  - Lamp OFF : Audio mode

#### (3) Call button

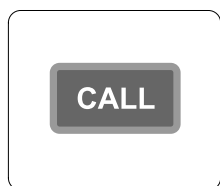

5513CD31C

- ① This button is used answer a call, last number radial, ring off.
  - ② For calling, press the button 0.5~1.5 seconds until the beep sounds.
- ※ **This can be used when the starting switch is ON.**

#### (4) Handsfree MIC

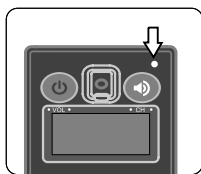

55I3CD31D

- ① This MIC transfers user voice to receiver of the call when making a call by handsfree.

#### (5) Seek button

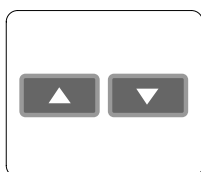

55I3CD31E

- ① If this button pressed, the radio automatically stops at the next frequency of broadcasting for your listening.
- ② This button enable to select the song of the MP3 from USB.
  - ▲ : Turn a station of higher frequency and the next song of the MP3.
  - ▼ : Turn a station of lower frequency and the previous song of the MP3.

#### (6) Mute button



55I3CD31F

- ① Short press this button to mute or cancel the mute (silence) while broadcasting.

#### (7) Mode button

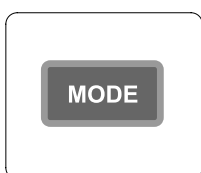

55I3CD31G

- ① Press the mode button to select the desired mode.
  - ② Radio → MP3 → AUX
- ※ **The LCD displayed each mode.**

### (8) Radio calling mode button

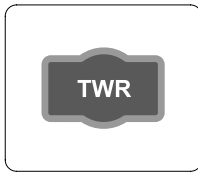

55I3CD31H

- ① Press this button, activated or deactivated the radio handsfree function.
- ② As long as you do not press this button, you can hear the other party.
- ③ The LED is turned ON when this button is activated.  
The LED turned OFF when the audio mode or the mobile phone handsfree calling mode is activated.

#### ※ Radio handsfree

**You can make a call to external worker without holding the radio by hand. (The radio is not installed to the machine).**

### (9) Talk button



55I3CD31J

- ① The call is connected while pressing this button (when TALK button is activated).
- ※ **Unlike mobile phones, when you want to talk through the radio, you need to press the button (Push-to-talk method).**  
**While one is talking through the radio, the other party can only listen to him/her.**

### (10) Handsfree jack



55I3CD31K

- ① Connect the jack cable when call by radio handsfree.



## 4) RADIO AND USB PLAYER

### ■ BASIC FUNCTIONS

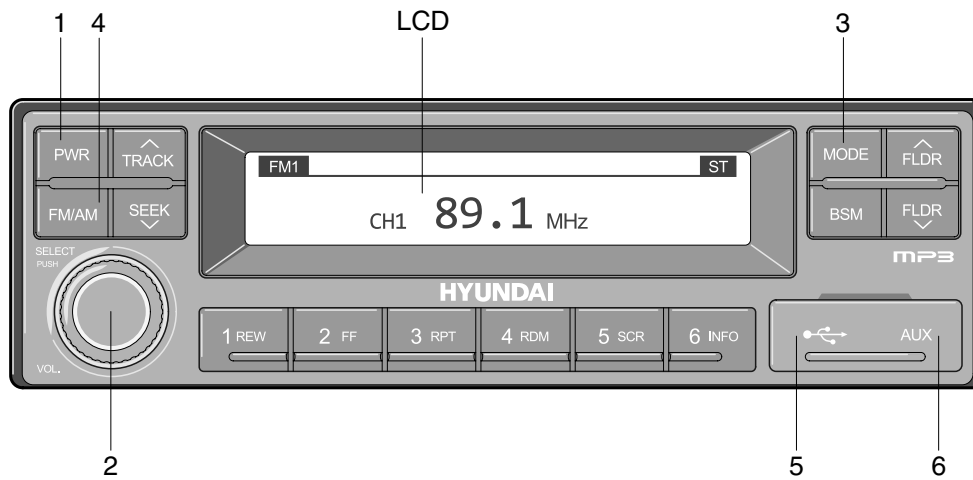

2209S3CD70

- |                               |                                  |
|-------------------------------|----------------------------------|
| 1 Power (PWR) button          | 4 Radio (FM/AM) selection button |
| 2 Volume/Sound setting button | 5 USB slot                       |
| 3 Mode selection button       | 6 AUX terminal                   |

#### (1) Power (PWR) button

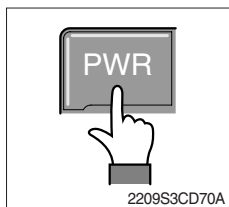

- ① Press the PWR button to turn on the audio. While the audio is operating, press the button to turn the power off.

#### (2) Volume/Sound setting button

##### • Volume (VOL) button

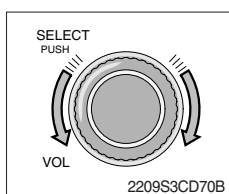

- ① Turn the VOL button clockwise to increase the volume and counter-clockwise to decrease the volume.

## • Sound setting

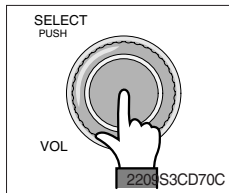

- ① Press the SELECT button to conduct sound setting.  
Each press of the button will change the sound setting in the following order.  
BASS → MIDDLE → TREBLE → BALANCE → EQ → BEEP
- ② After selecting the desired setting, turn the SELECT button clockwise/counter-clockwise to adjust the sound setting value.
- ③ **BASS adjustment**  
Turn the SELECT button clockwise to increase the bass and counter-clockwise to decrease the bass. BASS can be adjusted from max +10/min -10. If there are no adjustments for 3 seconds, the changes will be saved and the previous mode will be restored.
- ④ **MIDDLE adjustment**  
Turn the SELECT button clockwise to increase the middle and counter-clockwise to decrease the middle. MIDDLE can be adjusted from max +10/min -10. If there are no adjustments for 3 seconds, the changes will be saved and the previous mode will be restored.
- ⑤ **TREBLE adjustment**  
Turn the SELECT button clockwise to increase the treble and counter-clockwise to decrease the treble. TREBLE can be adjusted from max +10/min -10. If there are no adjustments for 3 seconds, the changes will be saved and the previous mode will be restored.
- ⑥ **Left/Right BALANCE adjustment**  
Turn the SELECT button clockwise to increase the right-side speaker volume and counter-clockwise to increase the left-side speaker volume. BALANCE can be adjusted from 10L/10R. If there are no adjustments for 3 seconds, the changes will be saved and the previous mode will be restored.
- ⑦ **EQ (EQUALIZER) adjustment**  
Turn the SELECT button clockwise/counter-clockwise to select the desired EQ. EQ settings are as shown below.  
Cls (classic) → Pop → Rock → Jazz → off  
If there are no adjustments for 3 seconds, the changes will be saved and the previous mode will be restored.  
※ **Upon selecting EQ, the BASS, MIDDLE and TREBLE values will be turned off.**  
**The BASS, MIDDLE, TREBLE values can be set only when EQ Off is selected.**
- ⑧ **BEEP sound adjustment**  
Turn the SELECT button clockwise/counter-clockwise to the beep sound ON/OFF. If there are no adjustments for 3 seconds, the changes will be saved and the previous mode will be restored.

### (3) MODE selection button

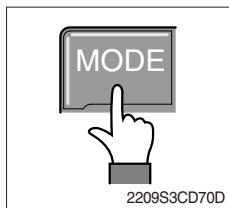

- ① Press the MODE button to change to RADIO/USB/AUX/iPod modes. However, the mode can be selected only when the respective media is connected.
  - ② If iPod is connected to the audio, the mode will change in the following order.  
RADIO → iPod → USB (handfree)
  - ③ If USB, AUX is connected to the audio, the mode will change in the following order.  
RADIO → USB(front) → USB(handfree) → AUX
- ※ **USB and AUX mode will operate only when corresponding devices are connected.**
  - ※ **When connecting iPod, AUX and front USB cannot be connected.**
  - ※ **The iPod is connected to the USB in the machine handfree.**

### (4) Radio (FM/AM) selection button

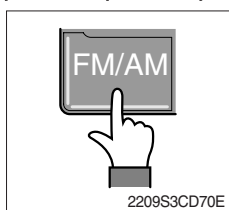

- ① Each press of the FM/AM button will change the radio mode in the following order.  
FM1 → FM2 → FM3 → AM
- ② Preset memory of up to FM : 18 stations, AM : 6 stations

### (5) USB slot

Connects USB to play USB music files.

### (6) AUX terminal

Connects AUX cable to play AUX music files.

■ RADIO

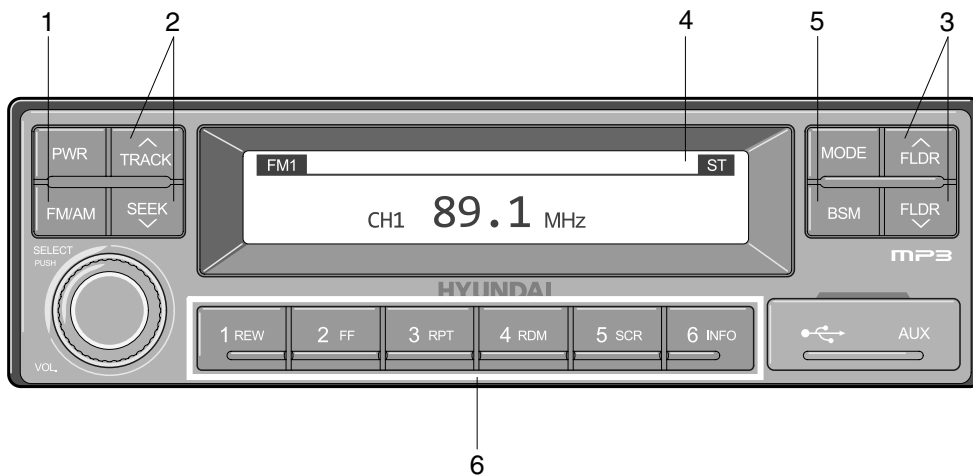

2209S3CD71

- |   |                                       |   |  |
|---|---------------------------------------|---|--|
| 1 | Radio (FM/AM) selection button        | 4 | LCD display                                    |
| 2 | TRACK/SEEK button                     | 5 | BSM (Best Station Memory) button               |
| 3 | Broadcast manual search (FLDR) button | 6 | Saving broadcast frequencies to PRESET numbers |

(1) Radio (FM/AM) selection button

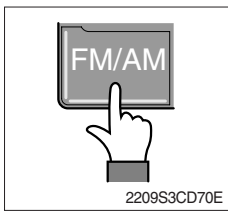

2209S3CD70E

① Each press of the FM/AM button will change the radio mode in the following order.

FM1 → FM2 → FM3 → AM

② In addition, pressing the FM/AM button when the starting switch is in ON state will turn the power on and activate the radio.

③ **Setting regional Radio Frequency**

▶ North America Frequency

Press the FM/AM and Preset 1 button simultaneously to set frequency in accordance to the North America Frequency settings. "nA" will become displayed on the LCD for one second.

FM : 87.7 ~ 107.9 MHz (200 KHz)

AM : 530 ~ 1710 KHz (10 KHz)

▶ Local/Middle East/Asia Frequency

Press the FM/AM and Preset 2 button simultaneously to set frequency in accordance to the Local/Middle East/Asia Frequency settings. "InT" will become displayed on the LCD for one second.

FM: 87.5 ~ 108 MHz (100 KHz)

AM: 531 ~ 1602 KHz (9 KHz)

▶ Europe Frequency

Press the FM/AM and Preset 3 button simultaneously to set frequency in accordance to the North America Frequency settings. "Eu" will become displayed on the LCD for one second.

FM: 87.5 ~ 108 MHz (50 KHz)

MW: 531 ~ 1602 KHz (9 KHz)

LW: 153 ~ 279 KHz (1 KHz)

## (2) TRACK/SEEK button

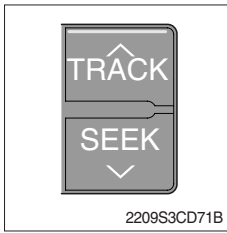

- ① As buttons used to automatically search broadcasts, pressing the button will automatically search and stop at a frequency with superior reception.

TRACK  $\wedge$  : Searches frequencies higher than current frequency

SEEK  $\vee$  : Searches frequencies lower than current frequency

- ※ When frequencies cannot be properly found due to weak broadcast reception, try using manual FLDR button. (Refer to manual FLDR button explanation below)

## (3) Broadcast manual search (FLDR) button

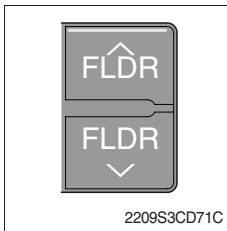

- ① As button used to search frequencies manually, a press of the SEEK step (refer to note below) will change the frequency.

Pressing and holding the button will continue changing the frequency. Releasing the button will stop the search at the current frequency.

FLDR  $\wedge$  : Searches frequencies higher than current frequency

FLDR  $\vee$  : Searches frequencies lower than current frequency

- ※ SEEK STEP : FM-100KHz, AM-9KHz

## (4) LCD display

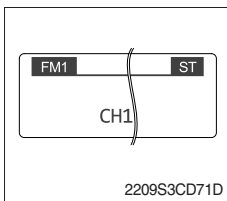

- ① The currently received broadcast frequency info and status are displayed.

## (5) BSM (Best Station Memory) button

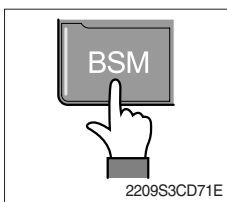

- ① Press and hold the BSM button to listen to the presets saved in FM BAND FM1, FM2, and FM3 or AM BAND AM for 5 seconds each.

When you find a station you wish to listen to, press the BSM button again to receive the selected broadcast.

- ② Shortly press the BSM button to automatically save frequencies with superior reception in presets (1REW~6INFO). The BSM feature will save AM frequencies in AM mode and FM frequencies in FM mode.

## (6) Saving broadcast frequencies to PRESET numbers

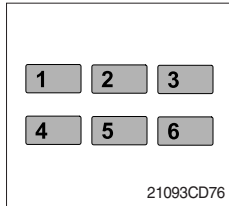

Up to 18 FM broadcasts and 6 AM broadcasts can be saved.

- ① Use the auto/manual search buttons to find the desired frequency.
  - ② Select the preset button (1REW~ 6INFO) to which you wish to save the selected frequency. Press and hold the preset button.
  - ③ The frequency will be saved to the preset button to a sound of a beep. The saved frequency number will be displayed on the LCD DISPLAY. (However, the beep will not sound if the beep function has been turned off in sound setting.)
  - ④ After saving is complete, pressing the preset button will play the corresponding broadcast frequency.
- ※ No beep sound signifies that the preset has not been saved. In this case, try again from the first step. (However, the beep will not sound if the beep function has been turned off in sound setting.)

■ USB CONNECTION

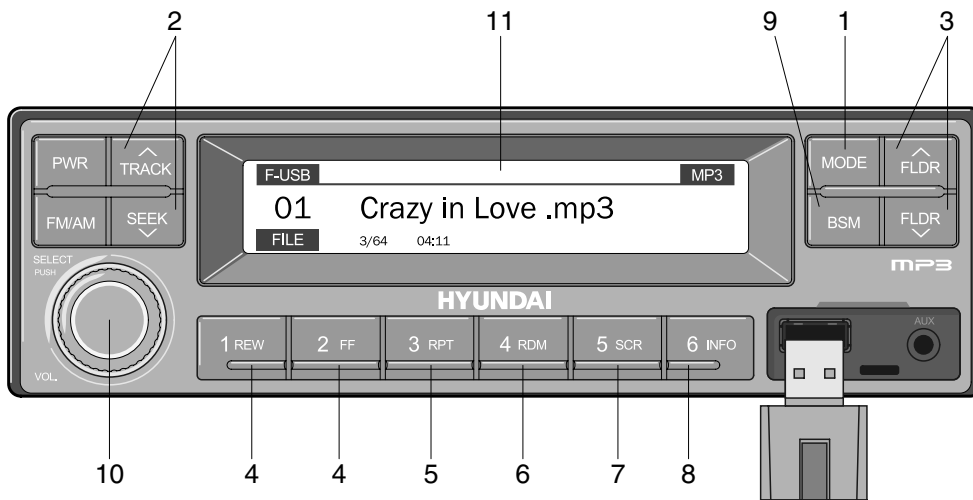

2209S3CD72

- |                             |   |
|-----------------------------|---|
| 1 USB selection button      | 7 Scroll (SCR) button                       |
| 2 TRACK UP/SEEK DOWN button | 8 View music info (INFO) button             |
| 3 FLDR UP/DOWN button       | 9 Scan button (BSM)                         |
| 4 FF/REW button             | 10 Finding and playing file (SELECT) button |
| 5 RPT/FOLDER RPT button     | 11 LCD display                              |
| 6 RDM/FOLDER RDM button     |   |

- Operates only when a USB is connected. Connecting a USB to the audio will automatically convert to USB mode.
- Connecting the USB when the starting switch is in ON state will turn the power on and automatically play the songs within the USB.

**(1) USB selection button**

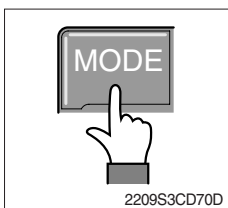

- ① While playing a different mode, press the MODE button to convert to USB mode. Connecting a USB to the audio will automatically convert to USB mode even if another mode is playing and automatically play the songs within the USB.
- ② If the USB is connected to both the front USB and handfree, then MODE is converted in the following order.  
RADIO → USB(front) → USB(handfree)

**(2) TRACK UP/SEEK DOWN button**

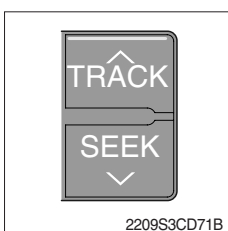

- ① While playing USB, press the TRACK ^ button to play the beginning of the next song.  
Press the SEEK v button to return to the beginning of the current song. Press the button again to play the beginning of the previous song.

### (3) FLDR UP/DOWN button

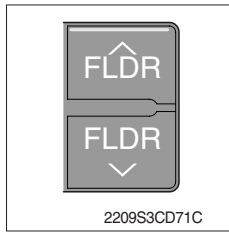

- ① If there are more than 2 folders in the USB, pressing the FLDR UP/DOWN button will move to the previous or next folder.
- ② If there are no folders in the USB, then pressing the button will move up/down within the folder in 10 file increments.

### (4) FF/REW button

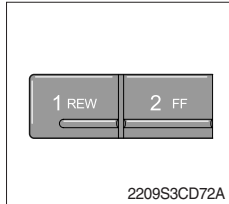

- ① While a USB is operating, press and hold the FF button to fast-forward the song. When fast-forward is complete, the next song will properly play from the beginning even if you continue holding the button. Press and hold the REW button to rewind the song. When rewind is complete, the current song will properly play from the beginning even if you continue holding the button. Shortly pressing the buttons will not operate the FF/REW.

### (5) RPT/FOLDER RPT button

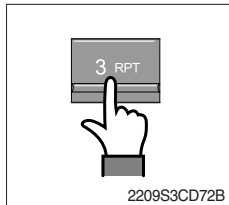

- ① While music is playing, shortly press the RPT button to repeat the currently playing song.
- ② (RPT function) Press and hold the RTP button to sequentially repeat all songs within the current folder. (FOLDER RPT, however, music files in the USB must be saved in folder format.)

### (6) RDM/FOLDER RDM button

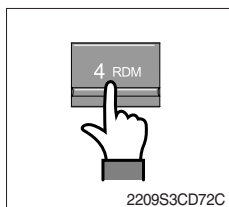

- ① While music is playing, shortly press the RDM button to randomly play the songs in the current folder. (RDM)
- ② While music is playing, press and hold the RDM button to randomly play the songs in the current folder. (FOLDER RDM, however, music files in the USB must be saved in folder format.)

### (7) Scroll (SCR) button

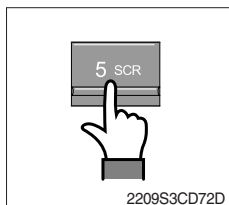

- ① Press the SCR button to turn ON/OFF the scroll function which scrolls the file name of the currently playing song on the LCD from right to left.



### (8) View music info (INFO) button

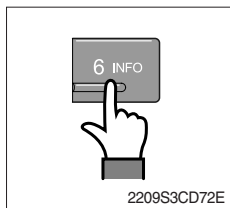

- ① Each time the INFO button is pressed, the info on the currently playing song will be displayed in the following order.  
FILE NAME → TITLE → ARTIST → ALBUM → DIR

### (9) Scan button (BSM)

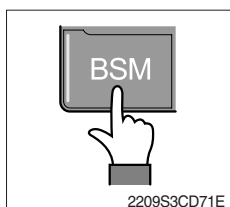

- ① While music is playing, shortly press the BSM button to scan each song within the USB for 10 seconds in sequential order. (SCN)
- ② Press and hold the BSM button to scan each song within the current folder for 10 seconds in sequential order. (FOLDER SCN, however, music files in the USB must be saved in folder format.)

### (10) Finding and playing file (SELECT) button

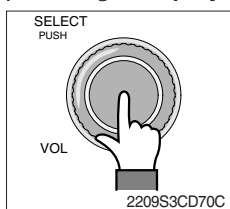

- ① While USB is playing, press and hold the SELECT button for over 3 seconds to enter FILE BROWSER mode and search for desired files.

After entering FILE BROWSER mode, turn the SELECT button left/

- ② right to find the desired folder. After finding the folder, press the SELECT button to select the folder. Turn the SELECT button left/right to find the desired song and press the SELECT button to play.

If there are no adjustments for 3 seconds after pressing the

- ③ SELECT button, the function will be turned off and the USB play screen will be displayed.

### (11) LCD display

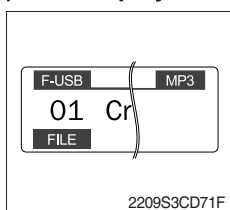

- ① Displays the info of the currently playing song.
  - F-USB : Displays USB is connected to the Audio Front
  - R-USB : Displays USB is connected to the handfree
  - RPT : Displays that repeat function is turned on
  - RPT : Displays that folder repeat function is turned on
  - RDM : Displays that random play is turned on
  - RDM : Displays that folder random play is turned on
  - SCR : Displays that SCROLL is turned on

## ■ IPOD CONNECTION

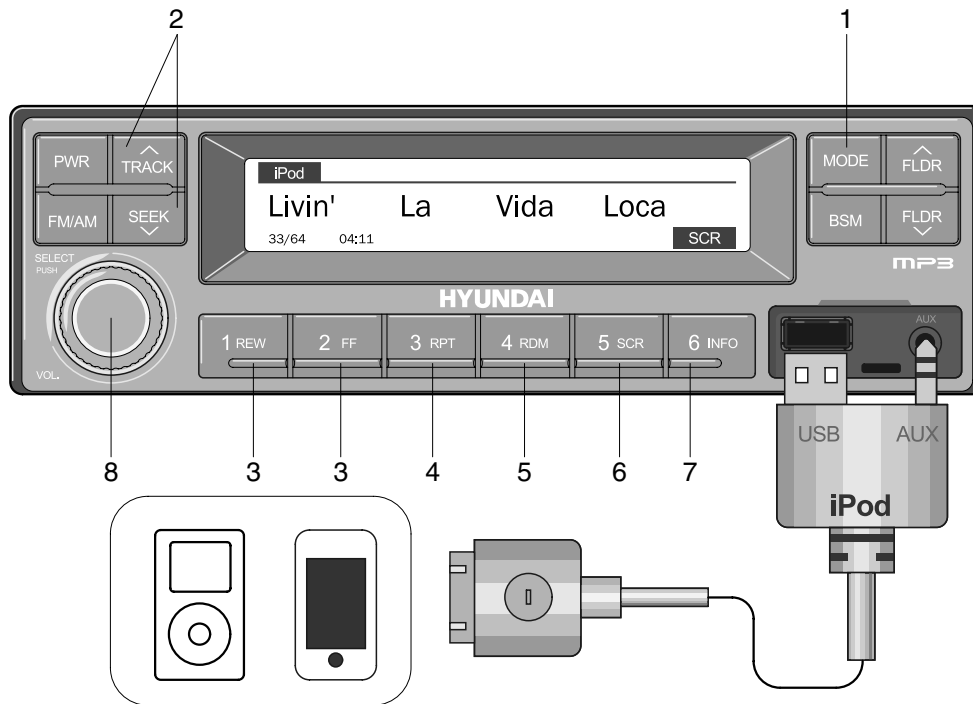

2209S3CD73

- |                             |  |
|-----------------------------|--|
| 1 iPod selection button     | 5 Random play (RDM) button                 |
| 2 TRACK UP/SEEK DOWN button | 6 Scroll (SCR) button                      |
| 3 FF/REW button             | 7 View music info (INFO) button            |
| 4 Repeat (RPT) button       | 8 Finding and playing file (SELECT) button |

- Operates only when an iPod is connected. Connecting an iPod to the audio will automatically convert to iPod mode. Connecting the USB when the starting switch is in ON state will turn the power on and automatically play the songs within the iPod.
- The iPod cable is supplied separately.

### (1) iPod selection button

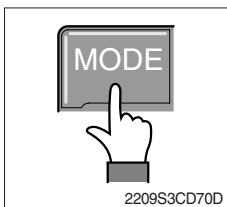

- ① While playing a different mode, press the MODE button to convert to iPod mode. Connecting an iPod to the audio will automatically convert to iPod mode even if another mode is playing and automatically play the songs within the iPod.

### (2) TRACK UP/SEEK DOWN button

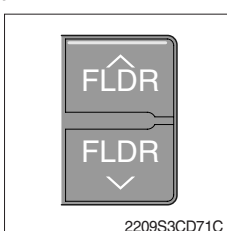

- ① While playing music, press the TRACK  $\wedge$  button to play the beginning of the next song. Press the SEEK  $\vee$  button to return to the beginning of the current song. Press the button again to play the beginning of the previous song.

### (3) FF/REW button

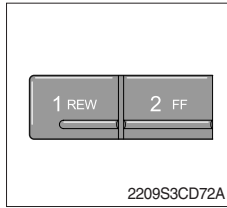

- ① While an iPod is operating, press and hold the FF button to fast-forward the song.
- ② When fast-forward is complete, the next song will properly play from the beginning even if you continue holding the button. Press and hold the REW button to rewind the song.
- ③ When rewind is complete, the current song will properly play from the beginning even if you continue holding the button.
- ④ Shortly pressing the buttons will not operate the FF/REW.

### (4) Repeat (RPT) button

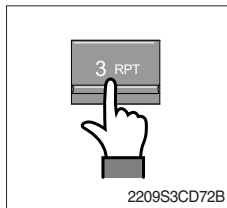

- ① While music is playing, press the RPT button to repeat the currently playing song.

### (5) Random play (RDM) button

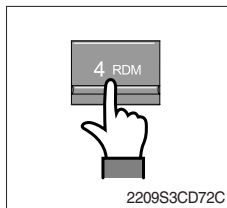

- ① While music is playing, press the RDM button to randomly play the songs.

### (6) Scroll (SCR) button

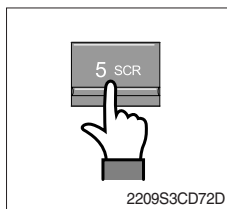

- ① Displays the file name of the currently playing song on the LCD. Here, the SCR button turns the file name SCROLL ON/OFF.

### (7) View music info (INFO) button

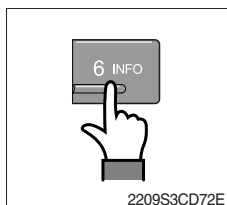

- ① Each time the INFO button is pressed, the info on the currently playing song will be displayed in order of ARTIST → ALBUM → TITLE.

## (8) Finding and playing file (SELECT) button

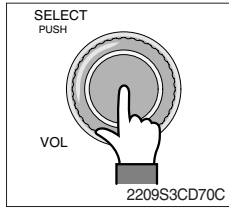

- ① While iPod is playing, press and hold the SELECT button for over 3 seconds to enter CATEGORY mode and search for desired files.
- ② After entering CATEGORY mode, turn the SELECT button left/right to find the desired category.
- ③ Category will be displayed in the following order.  
PLAYLISTS → ARTISTS → ALBUMS → GENRES → SONGS → COMPOSERS → AUDIOBOOKS → PODCASTS
- ④ After finding the category, press the SELECT button to select the category. Turn the SELECT button left/right to find the desired song and press the SELECT button to play.
- ⑤ If there are no adjustments for 3 seconds after pressing the SELECT button, the function will be turned off and the iPod play screen will be displayed.

## ■ AUX connection

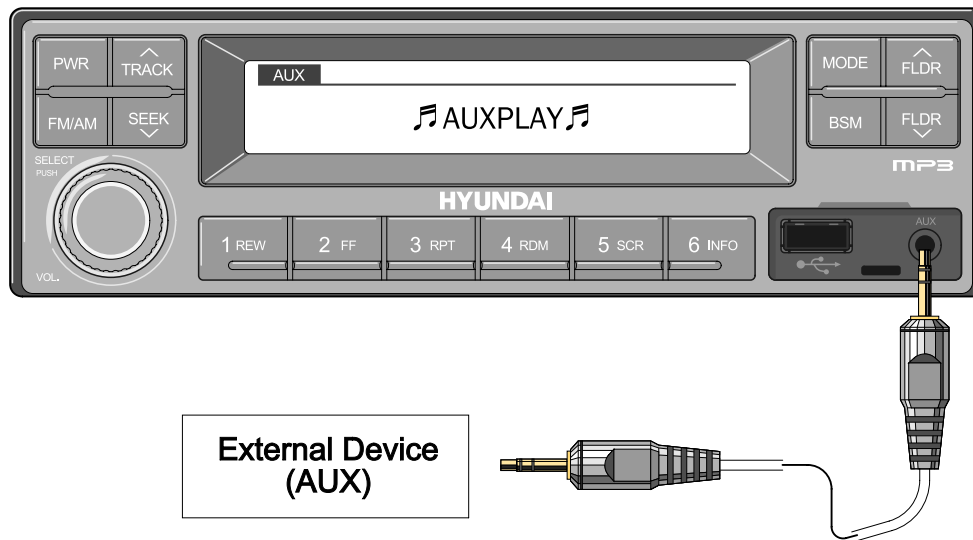

2209S3CD74

- Operates only when an external device is connected to AUX. Connecting an AUX device to the audio using the AUX cable will automatically convert to AUX mode.
- When an external device is connected, only the PWR, FM/AM, MODE, and VOL buttons can be operated.
- Settings can be made only through the external device connected to AUX.
- The AUX cable is supplied separately.

### (1) Connecting an external device using the AUX cable

- ① While playing a different mode, press the MODE button to convert to AUX mode.
- ② If an external device is connected to the Audio through the AUX terminal, AUX mode will automatically be converted and play music from AUX. Connecting the AUX when the starting switch is in ON state will turn the power on and automatically play the songs within the AUX.

## 5) SEAT

The seat is adjustable to fit the contours of the operator's body. It will reduce operator fatigue due to long work hours and enhance work efficiency.

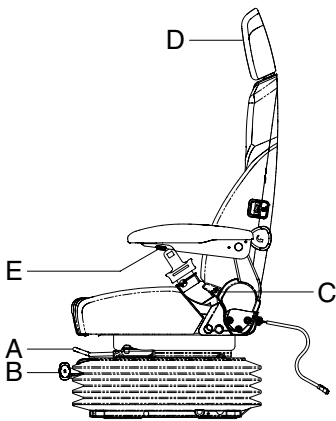
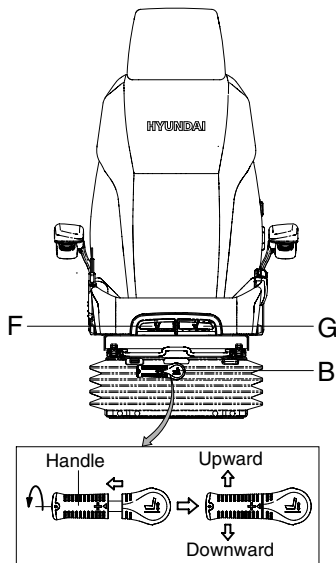

21093CD55

### (1) Forward/Backward adjustment (A)

- ① Pull lever A to adjust seat forward or backward.
- ② The seat can be moved forward and backward over 140 mm (5.5") in 13 steps.

### (2) Height/weight adjustment (B)

- ① Turn the handle to adjust seat upward or downward
  - Turn to clockwise, the seat is moved to upward and the weight is increased.
  - If it is turned to counterclockwise, the seat is moved to downward and the weight is decreased.

### ② Method of changing direction (up/down)

- First, pull the handle to outside.
- Second, rotate 180° and release the handle.

### (3) Reclining adjustment (C)

Pull lever C to adjust seat back rest.

### (4) Arm rest adjustment (E)

This can be adjusted by pushing the button E to right and left.

### (5) Head rest adjustment (D)

This is adjustable vertically to fit operator's requirements over 60 mm (2.4").

### (6) Seat cushion tilt adjustment (F)

Pull lever F to adjust seat cushion tilting angle.

### (7) Seat cushion length adjustment (G)

▲ Pull lever G to adjust seat cushion forward or backward.

▲ Always check the condition of the seat belt and mounting hardware before operating the machine. Replace the seat belt at least once every three years, regardless of appearance.

## 6) FUSE & RELAY BOX

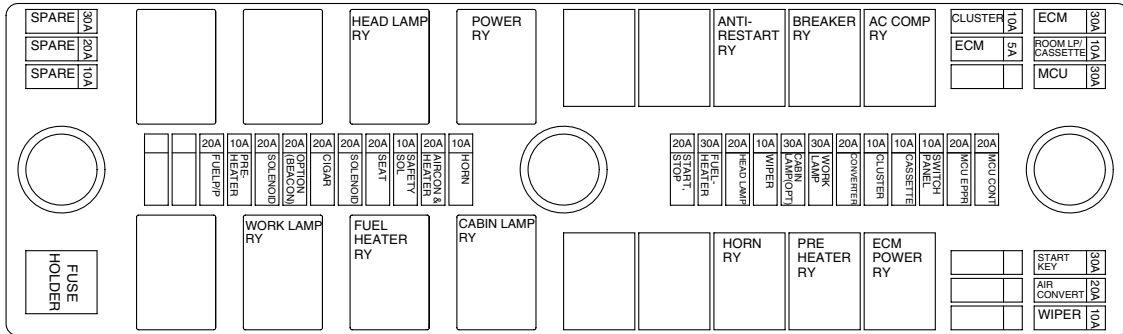

21093CD56

- (1) The fuses protect the electrical parts and wiring from burning out.
- (2) The fuse box cover indicates the capacity of each fuse and circuit it protects.

※ **Replace a fuse with another of the same capacity.**

▲ **Before replacing a fuse, be sure to turn OFF the starting switch.**

## 7) MCU

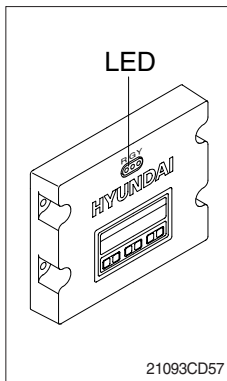

21093CD57

- (1) To match the pump absorption torque with the engine torque, MCU varies EPPR valve output pressure, which control pump discharge amount whenever feedbacked engine speed drops under the reference rpm of each mode set.
- (2) Three LED lamps on the MCU display as below.

LED lamp	Trouble	Service
G is turned ON	Normal	-
G and R are turned ON	Trouble on MCU	<ul style="list-style-type: none"> <li>• Change the MCU</li> </ul>
G and Y are turned ON	Trouble on serial communication line	<ul style="list-style-type: none"> <li>• Check if serial communication lines between controller and cluster are disconnected</li> </ul>
Three LED are turned OFF	Trouble on MCU power	<ul style="list-style-type: none"> <li>• Check if the input power wire (24 V, GND) of controller is disconnected</li> <li>• Check the fuse</li> </ul>

G : green, R : red, Y : yellow

## 8) EMERGENCY ENGINE SPEED CONTROL CONNECTOR

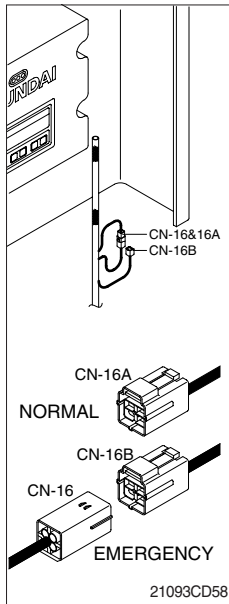

(1) When the CAN communication between the ECM and the MCU is abnormal due to malfunction of the MCU, change CN-16 connection from CN-16A to CN-16B and then control the engine speed by rotating accel dial switch.

※ **Never connect connector CN-16 with CN-16B when MCU is in normal operation.**

## 9) SERVICE METER

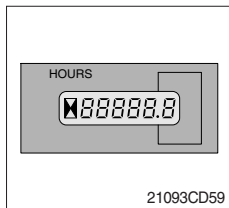

(1) This meter shows the total operation hours of the machine.

(2) Always ensure the operating condition of the meter during the machine operation. Inspect and service the machine based on hours as indicated in chapter 6, maintenance.

## 10) RS232 & J1939 SERVICE SOCKET

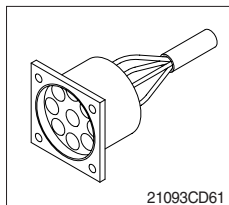

(1) MCU communicates the machine data with Laptop computer through RS232 service socket.

(2) ECM communicates the engine data with cummins INSITE adapter through J1939 service socket.

① ECM fault code check

② ECM program change

③ Engine data monitoring & test



## 11) UPPER WINDSHIELD

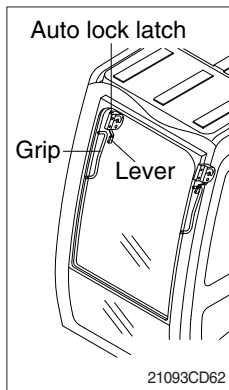

(1) Perform the following procedure in order to open the upper windshield.

- ① Pull both levers with hold both grips that are located at the top of the windshield frame and push the windshield upward.
- ② Hold both grips and back into the lock position until auto lock latch is engaged, then release the lever locked position.

**▲ When working, without having locked the windshield by the auto lock (by pushing the windshield to the rear until it's completely fixed), please be careful as it can cause personal injury if the windshild is not fixed or falls off.**

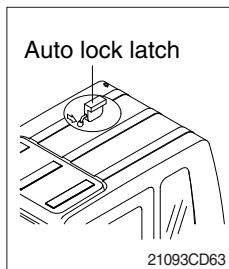

(2) Perform the following procedure in order to close the upper windshield.

- ① Pull the lever of the auto lock latch in order to release the auto lock latch.
- ② Reverse above step ① and ② in order to close the upper windshield.

## 1. SUGGESTION FOR NEW MACHINE

- 1) It takes about 100 operation hours to enhance its designed performance.
- 2) Operate according to below three steps and avoid excessive operation for the initial 100 hours.

Service meter	Load
Until 10 hours	About 60 %
Until 100 hours	About 80 %
After 100 hours	100 %

※ **Excessive operation may deteriorate the potential performance of machine and shorten lifetime of the machine.**

### 3) Be careful during the initial 100 hours operation

- (1) Check daily for the level and leakage of coolant, engine oil, hydraulic oil and fuel.
- (2) Check regularly the lubrication and fill grease daily all lubrication points.
- (3) Tighten bolts.
- (4) Warm up the machine fully before operation.
- (5) Check the gauges occasionally during the operation.
- (6) Check if the machine is operating normally during operation.

### 4) Replace followings after initial operation hours.

Checking items	Hours
Engine oil	50
Engine oil filter element	
Fuel filter	
Prefilter	
Hydraulic oil return filter element	250
Hydraulic oil tank drain filter cartridge	
Line filter element	
Swing reduction gear oil	500
Travel reduction gear oil	

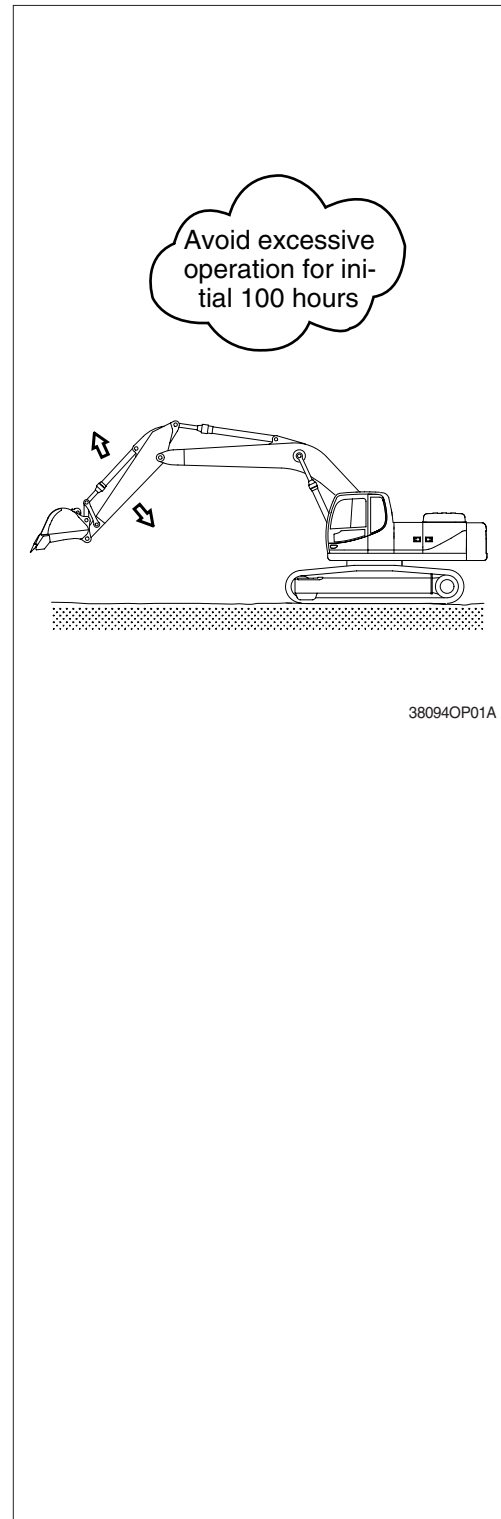

## 2. CHECK BEFORE STARTING THE ENGINE

- 1) Look around the machine and under the machine to check for loosen nut or bolts, collection of dirt, or leakage of oil, fuel or coolant and check the condition of the work equipment and hydraulic system. Check also loosen wiring, and collection of dust at places which reach high temperature.  
※ Refer to the daily check on the chapter 6, maintenance.
- 2) Adjust seat to fit the contours of the operator's body for the pleasant operation.
- 3) Adjust the rear view mirror.

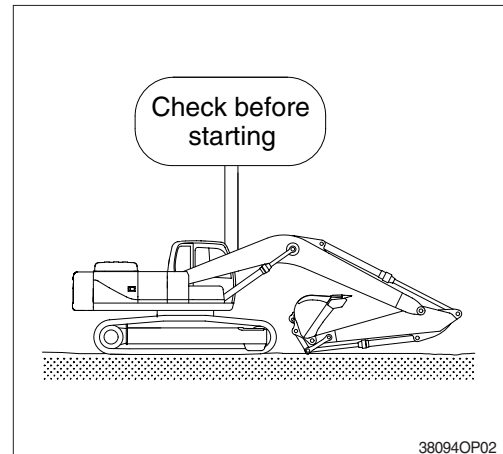

### 3. STARTING AND STOP THE ENGINE

#### 1) CHECK INDICATOR LIGHTS

- (1) Check if all the operating levers are in the neutral position.
- (2) Turn the starting switch to the ON position.  
Buzzer sounding for 4 seconds with HYUNDAI logo on cluster.
  - ※ If the ESL mode is set to the enable, enter the password to start engine.
  - ※ If the password has failed 5 times, please wait 30 minutes before re-attempting to enter the password.
  - ※ Refer to page 3-19 for ESL mode.
- (3) After initialization of cluster, the operating screen is displayed on LCD (1).  
Also, self-diagnostic function is carried out.



#### 2) STARTING ENGINE IN NORMAL TEMPERATURE

- ※ Sound the horn to warn the surroundings after checking if personnel or obstacles are in the area.
- (1) Turn the accel dial switch to low idle position.
  - (2) Turn the starting switch to START position to start the engine.
    - ※ Do not hold the starting switch in the START position for longer than 20 seconds.  
The start system may be seriously damaged.
    - ※ If the engine does not start, allow the stator to cool for about 2 minutes before re-attempting to start the engine again.
  - (3) Release the starting switch instantly after the engine starts to avoid possible damage to the starting motor.

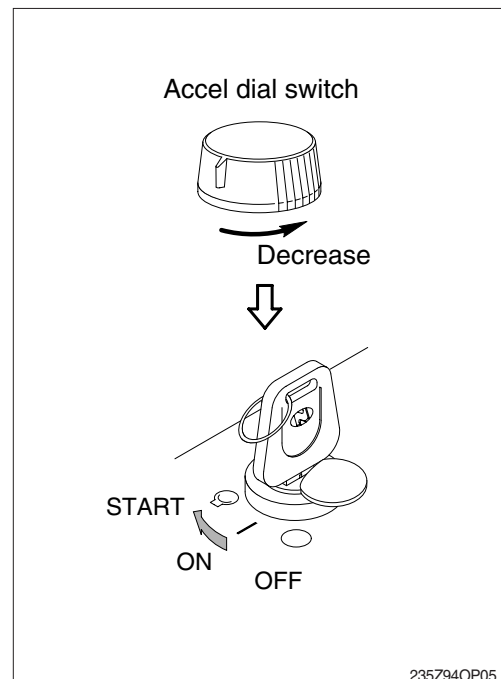

### 3) STARTING ENGINE IN COLD WEATHER

- ※ Sound horn to warn surroundings after checking if there are obstacles in the area.
- ※ Replace the engine oil and fuel referring to recommended oils at page 2-12.
- ※ Fill the anti-freeze solution to the coolant as required.
- ※ If you turn ON the starting switch, the fuel warmer is automatically operated to heat the fuel by sensing the coolant temperature.

- (1) Check if all the levers are in the neutral position.
- (2) Turn the accel dial switch to low idle position.
- (3) Turn the starting switch to the ON position, and wait 1~2 minutes. More time may take according to ambient temperature.
- (4) Wait for five minutes to warm up the engine after the preheating pilot lamp off, and then turn the starting switch to the START position to start the engine.
  - ※ If the engine does not start, allow the starter to cool for about 2 minutes before attempting to start the engine again.
- (5) Release the starting switch immediately after starting engine.
- (6) If the temperature of the coolant is lower than 30°C the warming up automatically starts.
  - ※ Do not operate the working devices, or convert the operation mode into other mode during the warming up.

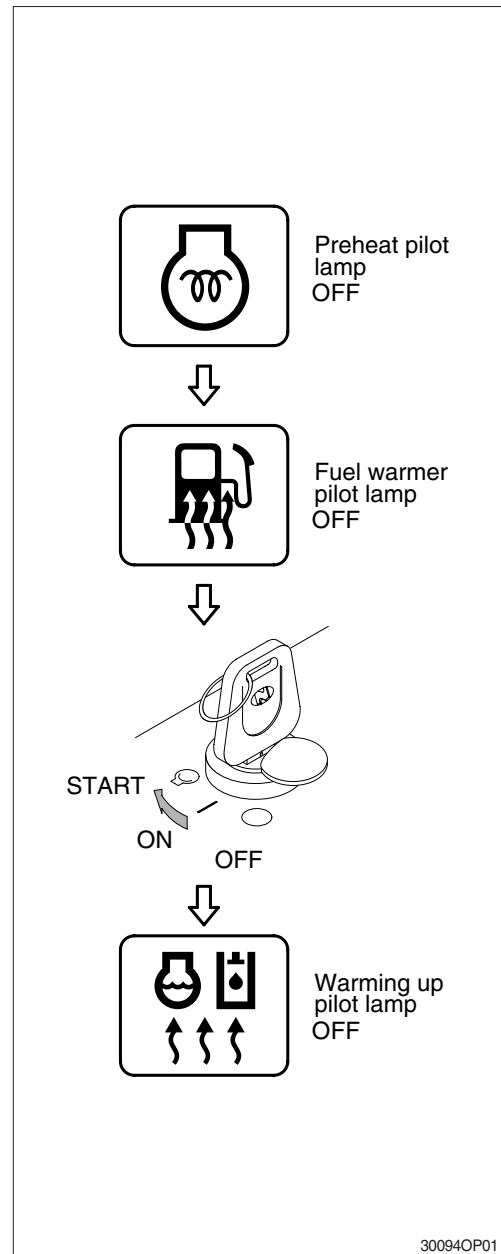

#### 4) INSPECTION AFTER ENGINE START

Inspect and confirm the following after engine starts.

- (1) Is the level gauge of hydraulic oil tank in the normal level?
  - (2) Are there leakages of oil or water?
  - (3) Are all the warning lamps turned OFF (1-8)?
  - (4) Are the indicator of water temperature gauge (9) and hydraulic temperature gauge (10) in the operating range?
  - (5) Are the engine sound and the color of exhaust gas normal?
  - (6) Are the sound and vibration normal?
- ※ **Do not increase engine speed quickly after starting, it can damage engine or turbocharger.**
  - ※ **If there are problems in the cluster, stop the engine immediately and correct problems as required.**



2609A4OP03

#### 5) WARMING-UP OPERATION

- ※ **The most suitable temperature for the hydraulic oil is about 50°C (122°F).**  
It can cause serious trouble in the hydraulic system by sudden operation when the hydraulic oil temperature is below 25°C (77°F).  
Then temperature must be raised to at least 25°C (77°F) before starting work.

- (1) Run the engine at low idle speed for 5 minutes.
- (2) Speed up the engine by accel dial and run the engine at mid-range speed.
- (3) Operate bucket lever for 5 minutes.
  - ※ **Do not operate anything except bucket lever.**
- (4) Run the engine at the high speed and operate the bucket lever and arm lever for 5-10 minutes.
  - ※ **Operate only the bucket lever and arm lever.**
- (5) This warming-up operation will be completed by operation of all cylinders several times, and operation of swing and traveling.

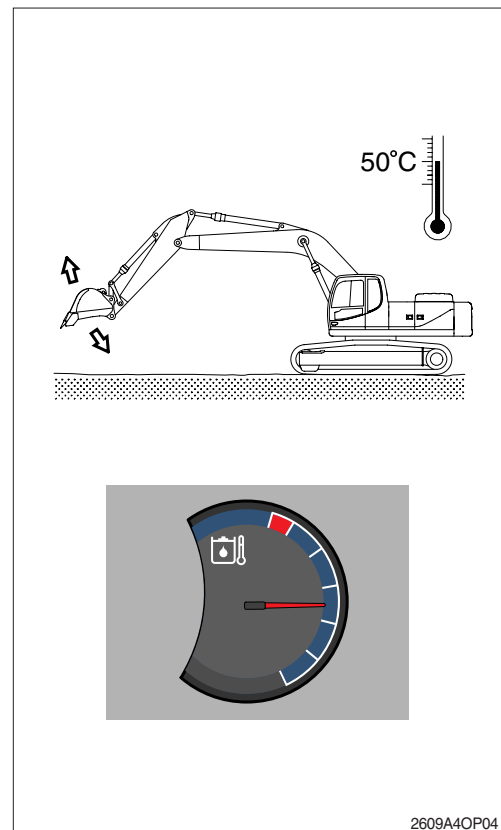

2609A4OP04

## 6) TO STOP THE ENGINE

- ※ If the engine is abruptly stopped before it has cooled down, engine life may be greatly shortened. Consequently, do not abruptly stop the engine apart from an emergency.
  - ※ In particular, if the engine has overheated, do not abruptly stop it but run it at medium speed to allow it to cool gradually, then stop it.
- (1) Down the bucket on the ground then put all the levers in the neutral position.
  - (2) Run the engine at low idle speed for about 5 minutes.
  - (3) Return the key of starting switch to the OFF position.
  - (4) Remove the key to prevent other people using the machine and LOCK safety lever.
  - (5) Lock the cab door.

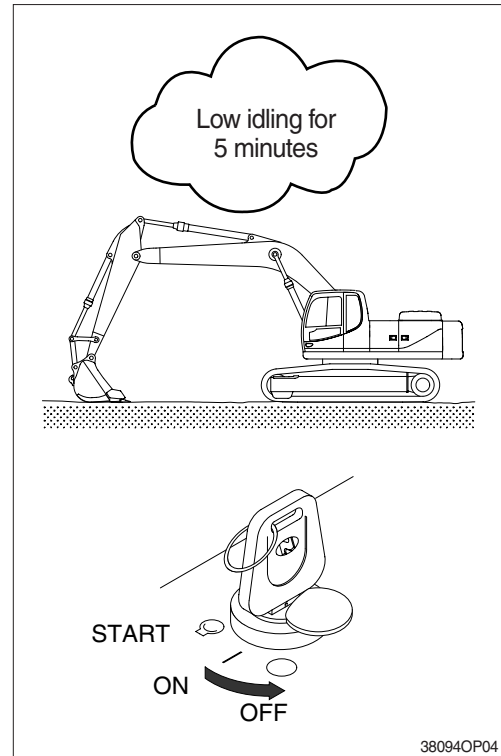

## 4. MODE SELECTION SYSTEM

### 1) STRUCTURE OF MECHATRONICS SYSTEM

CAPO, Computer Aided Power Optimization system, is the name of mode selection system developed by Hyundai.

※ Please refer to chapter 3, cluster for below modes setting.

#### (1) Power mode

Power mode designed for various work loads supports high performance and reduces fuel consumption.

- P mode : Heavy duty power
- S mode : Standard power
- E mode : Economy power

#### (2) Work mode

One of the two work modes can be selected for the optimal work condition of the machine operation.

##### ① General work mode (bucket)

When key switch is turned ON, this mode is selected automatically.

##### ② Work tool mode (breaker, crusher)

It controls the pump flow and system pressure for the optimal operation of breaker or crusher.

#### (3) User mode

① User mode is useful for setting the user preferable power quickly.

(engine speed, power shift and idle speed)

② There are two methods for use of user mode.

##### a. In operation screen

User mode switch is used to memorize the current machine operating status and activate the memorized user mode.

Refer to page 3-13.

##### b. In menu

Engine high idle rpm, auto idle rpm and pump torque (power shift) can be modulated and memorized separately in menu status.

- Each memory mode has a initial set which are mid-range of max engine speed, power shift and auto idle speed.





- High idle rpm, auto idle rpm and EPPR pressure can be adjusted and memorized in the U-mode.



※ Refer to the page 3-15 for setting the user mode (available on U mode only).

· LCD segment vs parameter setting

Step ( )	Engine speed (rpm)	Idle speed (rpm)	Power shift (bar)
1	1300	700	0
2	1400	800	3
3	1500	One touch decel low idle (900)	6
4	1600	950	9
5	1650	Auto decel rpm (1000)	12
6	1700	1050	16
7	1750	1100	20
8	1800	1150	26
9	1850	1200	32
10	1900	1250	38



#### (4) Travel mode

-  : Low speed traveling.
-  : High speed traveling.

#### (5) Auto idle mode

- Pilot lamp ON : Auto idle function is activated.
- Pilot lamp OFF : Auto idle function is canceled.

## (6) Monitoring system

Information of machine performance as monitored by the MCU can be displayed on the LCD. Refer to the page 3-16.

## (7) Self diagnostic system

### ① MCU (Machine Control Unit)

The MCU diagnoses machine status and problems and displays fault code in the cluster (fault code detected by MCU is composed of HCESPN and FMI).

### ② Engine ECM (Electronic Control Module)

If the engine or relevant system has problem, engine ECM detects and displays on the LCD as fault codes (this code is composed of SPN and FMI).

※ Refer to the page 3-16 for LCD display.

## (8) Anti-restart system

The system protects the starter from inadvertent restarting after the engine is already operational.

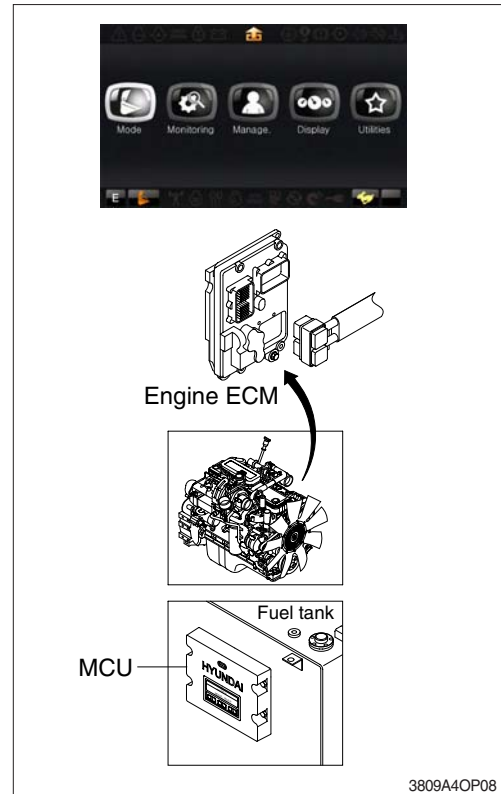

## 2) HOW TO OPERATE MODE SELECTION SYSTEM

### (1) When start key switch is turned ON

- ① When start key switch is turned on, the cluster turns on and buzzer sounds for 4 seconds. And then main information as gauges and engine speed are displayed on LCD.
- ② Initial default mode settings are displayed in the cluster.

Mode		Status
Power mode	E	ON
Work mode		ON
Travel mode	Low (	ON
Auto idle		ON

※ These setting can be changed at U mode.

- ③ Self-diagnostic function can be carried out from this point.

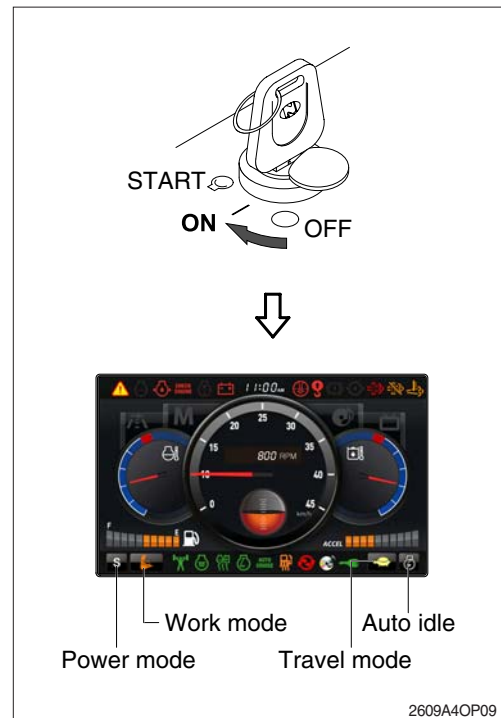

**(2) After engine start**

- ① When the engine is started, rpm display indicates low idle,  $800 \pm 100$  rpm.
- ② If coolant temperature is below  $30^{\circ}\text{C}$ , the warming up pilot lamp lights ON and after 4 seconds the engine speed increases to  $1000 \pm 100$  rpm automatically to warm up the machine.
  - After 2-3 minutes, you can select any mode depending on job requirement.

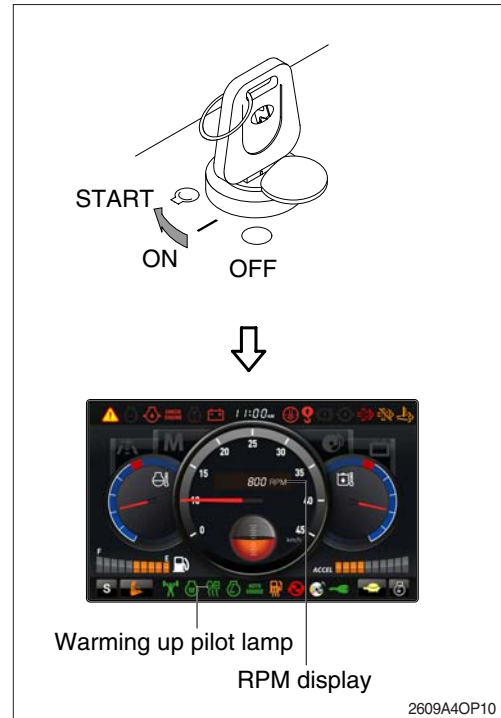

**3) SELECTION OF POWER MODE**

**(1) E mode**

The accel dial is set 10 and the auto idle mode is canceled.

Engine rpm	Effect
$1550 \pm 50$	Variable power control in proportion to lever stroke (improvement in fuel efficiency) ※ Same power as S mode in full lever operation.

※ When the accel dial is located below 9 the engine speed decreases about 50~100 rpm per dial set.

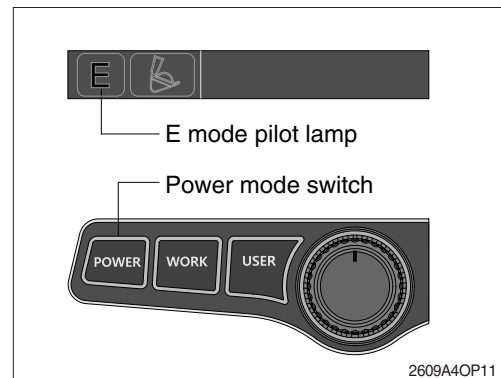

**(2) S mode**

The accel dial is set 10 and the auto idle mode is canceled.

Engine rpm	Effect
$1650 \pm 50$	Standard power

※ When the accel dial is located below 9 the engine speed decreases about 50~100 rpm per dial set.

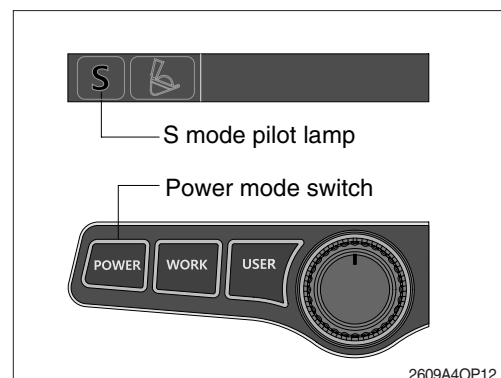

### (3) P mode

The accel dial is set 10 and the auto idle mode is canceled.

Engine rpm	Effect
1750 ± 50	Approximately 120 % of power and speed available than S mode.

※ When the accel dial is located below 9 the engine speed decreases about 50~100 rpm per dial set.

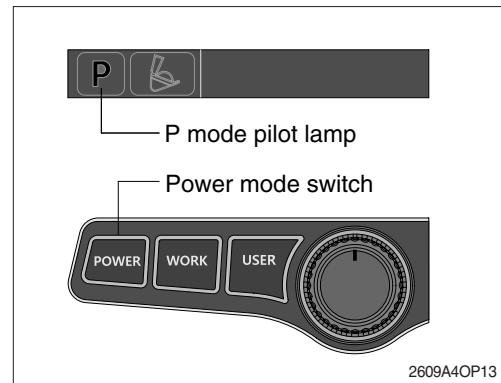

## 5. OPERATION OF THE WORKING DEVICE

※ **Confirm the operation of control lever and working device.**

- 1) Left control lever controls arm and swing.
- 2) Right control lever controls boom and bucket.
- 3) When you release the control lever, control lever returns to neutral position automatically.

※ **When operating swing, consider the swing distance by inertia.**

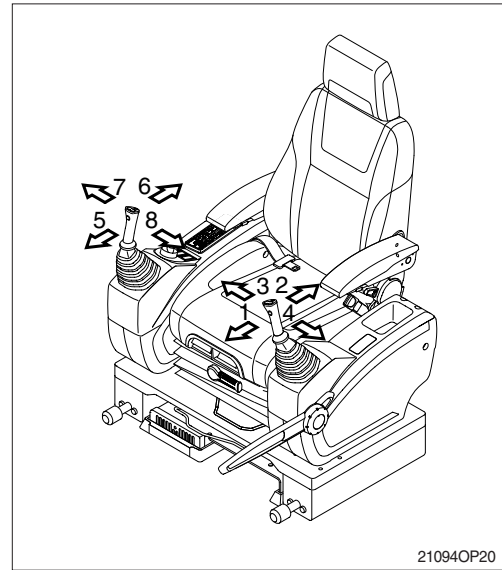

※ **Left control lever**

- 1 Arm roll-out
- 2 Arm roll-in
- 3 Swing right
- 4 Swing left

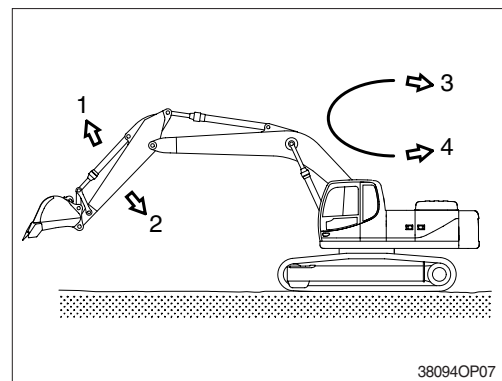

※ **Right control lever**

- 5 Boom lower
- 6 Boom raise
- 7 Bucket roll-out
- 8 Bucket roll-in

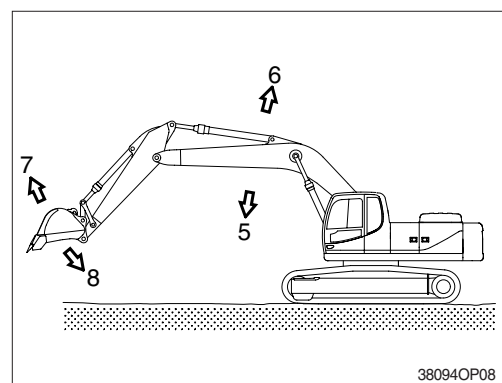

## 6. TRAVELING OF THE MACHINE

### 1) BASIC OPERATION

#### (1) Traveling position

It is the position which the traveling motor is in the rear and the working device is forward.

- ▲ **Be careful as the traveling direction will be reversed when the whole machine is swung 180 degree.**

#### (2) Traveling operation

It is possible to travel by either travel lever or pedal.

- ※ **Do not travel continuously for a long time.**
- ※ **Reduce the engine speed and travel at a low speed when traveling on uneven ground.**

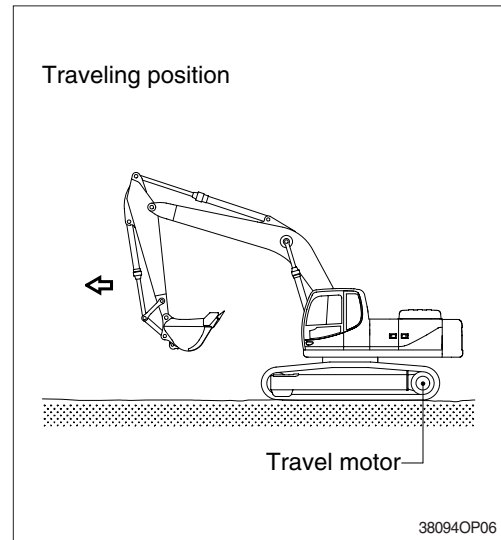

#### (3) Forward and backward traveling

When the left and right travel lever or pedal are pushed at the same time, the machine will travel forward or backward.

- ※ **The speed can be controlled by the operation stroke of lever or pedal and change of direction will be controlled by difference of the left and right stroke.**

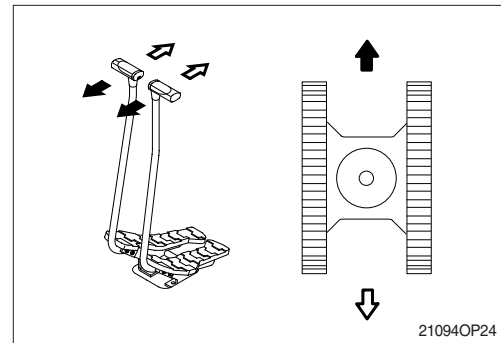

#### (4) Pivot turning

Operating only one side of lever or pedal make the change of direction possible by moving only one track.

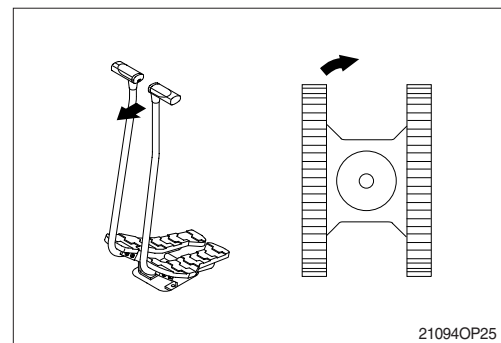

#### (5) Counter rotation

It is to change the direction at the original place by moving the right and left track. Both side of lever or pedal are operated to the other way at the same time.

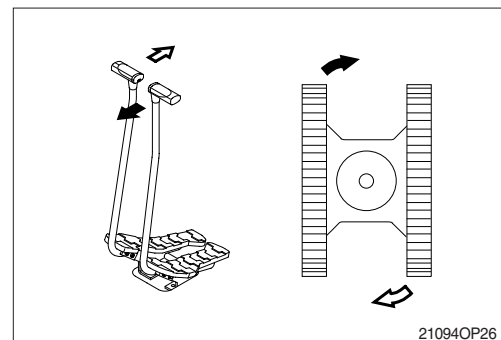

## 2) TRAVELING ON A SLOPE

- (1) Make sure that the travel lever is properly maneuvered by confirming the travel motor is in the right location.
  - (2) Lower the bucket 20 to 30 cm (1 ft) to the ground so that it can be used as a brake in an emergency.
  - (3) If the machine starts to slide or loses stability, lower the bucket immediately and brake the machine.
  - (4) When parking on a slope, use the bucket as a brake and place blocks behind the tracks to prevent sliding.
- ※ Machine cannot travel effectively on a slope when the oil temperature is low. Do the warming-up operation when it is going to travel on a slope.
- ▲ Be careful when working on slopes. It may cause the machine to lose its balance and turn over.
- ▲ Be sure to keep the travel speed switch on the LOW (turtle mark) while traveling on a slope.

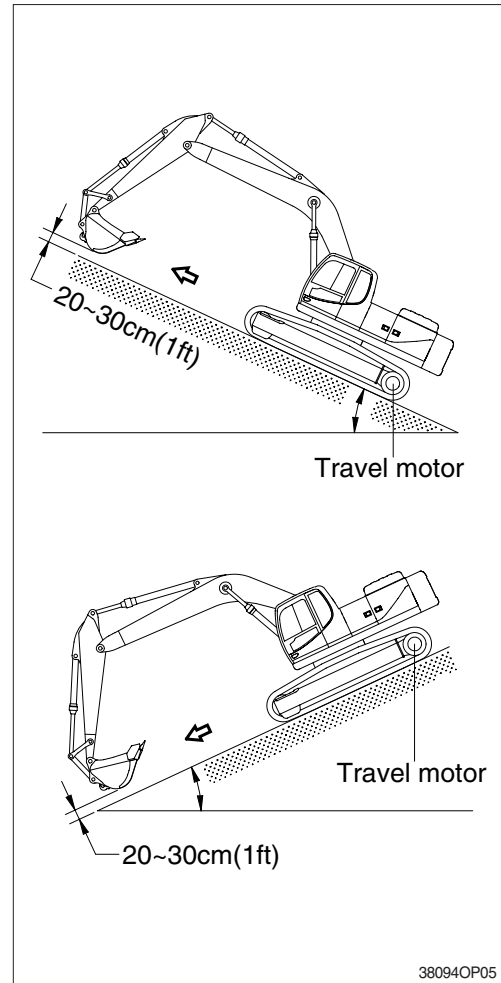

## 3) TRAVELING ON SOFT GROUND

- ※ If possible, avoid to operate on soft ground.
- (1) Move forward as far as machine can move.
  - (2) Take care not to go beyond the depth where towing is impossible on soft ground.
  - (3) When driving becomes impossible, lower bucket and use boom and arm to pull the machine. Operate boom, arm, and travel lever at the same time to avoid the machine sinking.

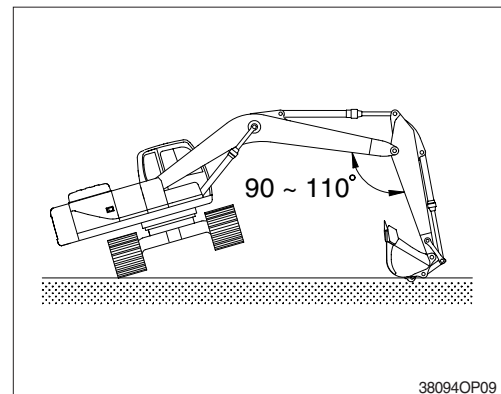

#### 4) TOWING THE MACHINE

Tow the machine as follows when it can not move on it's own.

- (1) Tow the machine by other machine after hook the wire rope to the frame as shown in picture at right.
  - (2) Hook the wire rope to the frame and put a support under each part of wire rope to prevent damage.
- ※ **Never tow the machine using only the tie hole, because this may break.**
  - ▲ **Make sure no personnel are standing close to the tow rope.**

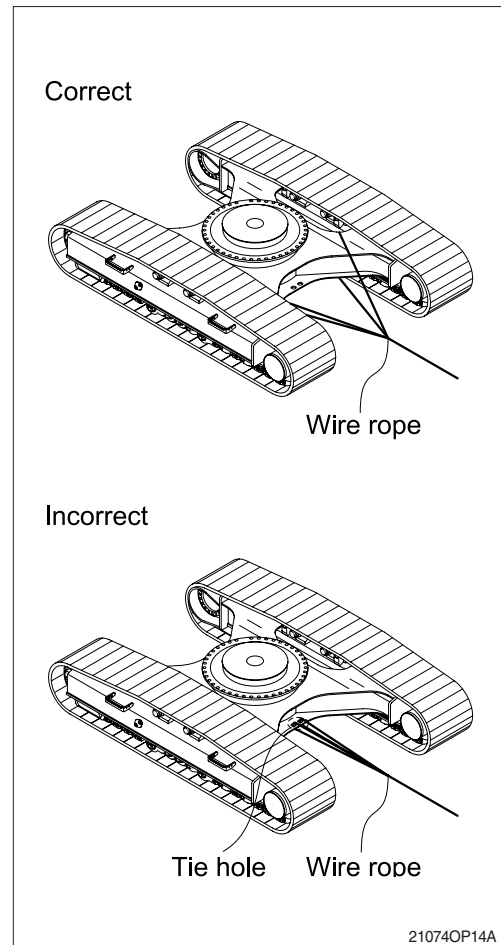



## 7. EFFICIENT WORKING METHOD

- 1) Do the digging work by arm.

Use the pulling force of arm for digging and use together with the digging force of the bucket if necessary.

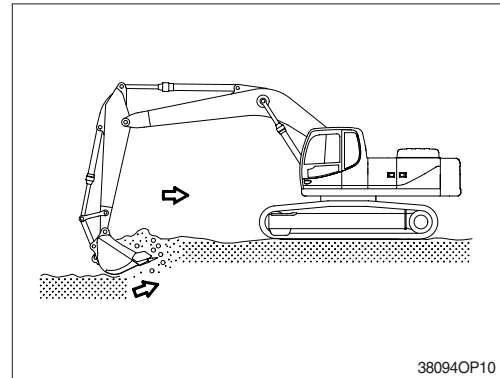

- 2) When lowering and raising the boom operate softly for the beginning and the end.

In particularly, sudden stops while lowering the boom may cause damage to the machine.

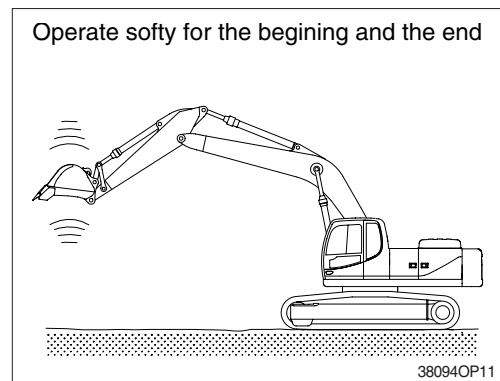

- 3) The digging resistance and wearing of tooth can be reduced by putting the end of bucket tooth to the digging direction.

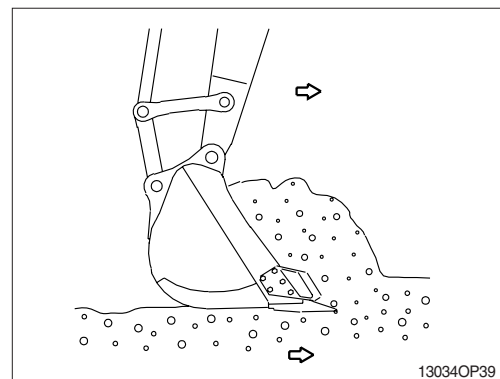

- 4) Set the tracks parallel to the line of the ditch to be excavated when digging ditch. Do not swing while digging.

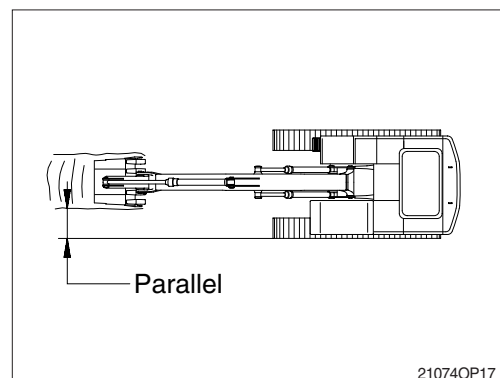

- 5) Dig slowly with keeping the angle of boom and arm, 90-110 degree when maximum digging force is required.

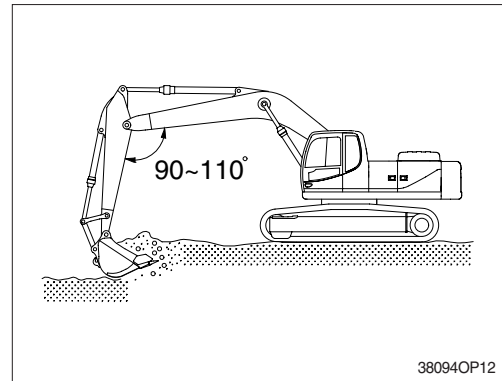

- 6) Operate leaving a small safety margin of cylinder stroke to prevent damage of cylinder when working with the machine.

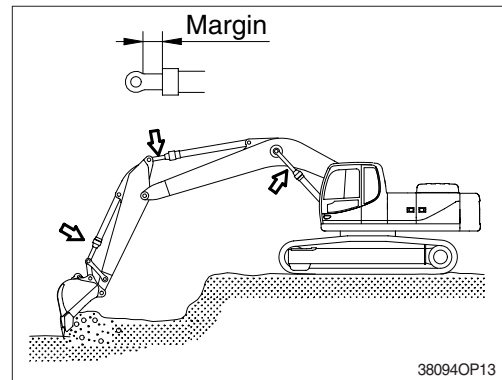

- 7) Keep the bucket to the dumping position and the arm horizontal when dumping the soil from the bucket.  
Operate bucket lever 2 or 3 times when hard to dump.

※ Do not use the impact of bucket tooth when dumping.

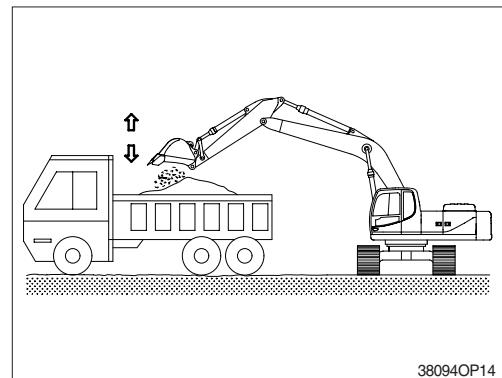

- 8) Operate stop of swing considering the swing slip distance is created by inertia after neutralizing the swing lever.

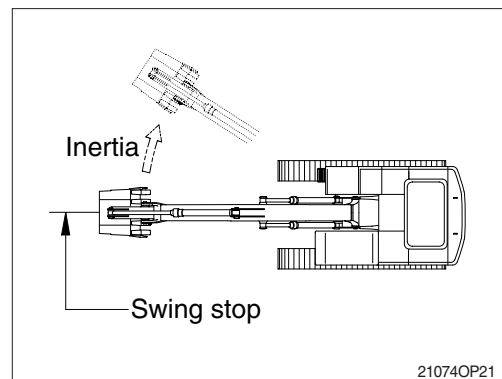

- 9) If the excavation is in an underground location or in a building, make sure that there is adequate overhead clearance and that there is adequate ventilation.

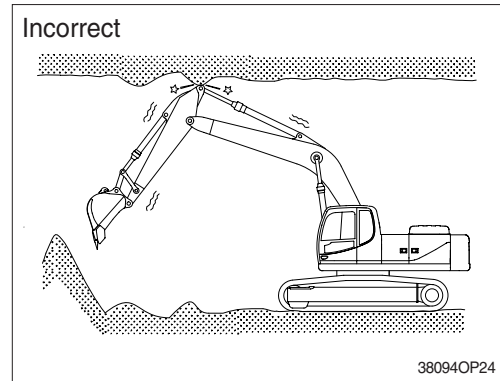

- 10) Do not use the dropping force of the work equipment for digging.  
The machine can be damaged by the impact.

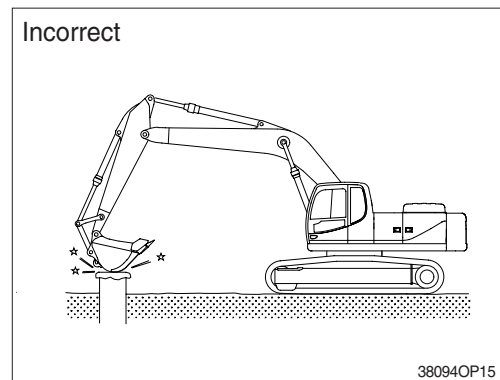

- 11) Do not use the bucket to crack hard objects like concrete or rocks.  
This may break a tooth or pin, or bend boom.

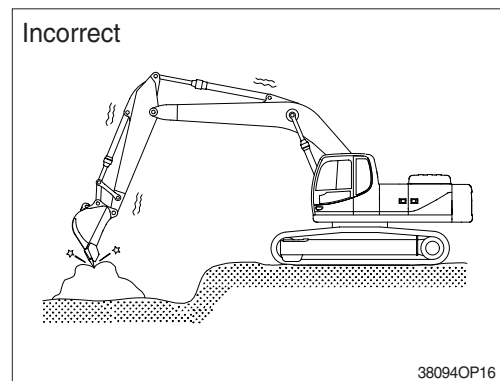

**12) NEVER CARRY OUT EXCESSIVE OPERATIONS**

Operation exceeding machine performance may result in accident or failure.

Carry out lifting operation within specified load limit.

Never carry out operations which may damage the machine such as overload or over-impact-load.

Never travel while carrying a load.

In case you need installing over load warning device for object handling procedure, please contact Hyundai distributor.

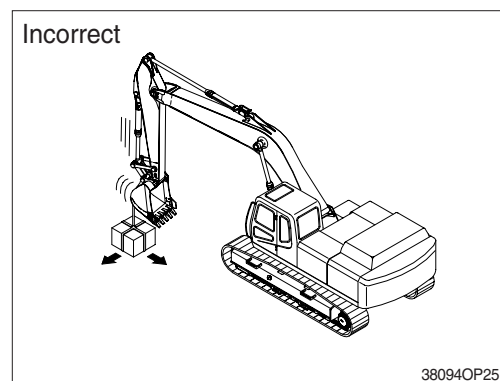

### 13) BUCKET WITH HOOK

When carrying out lifting work, the special lifting hook is necessary.

The following operations are prohibited.

- Lifting loads with a wire rope fitted around the bucket teeth.
- Lifting loads with the wire rope wrapped directly around the boom or arm.

When performing lifting operation, securely hook the wire rope onto the special lifting hook.

When performing lifting operation, never raise or lower a person.

Due to the possible danger of the load falling or of collision with the load, no persons shall be allowed in the working area.

Before performing lifting operation, designate an operation supervisor.

Always execute operation according to his instructions.

- Execute operating methods and procedures under his direction.
- Select a person responsible for signaling. Operate only on signals given by such person.

Never leave the operator's seat while lifting a load.

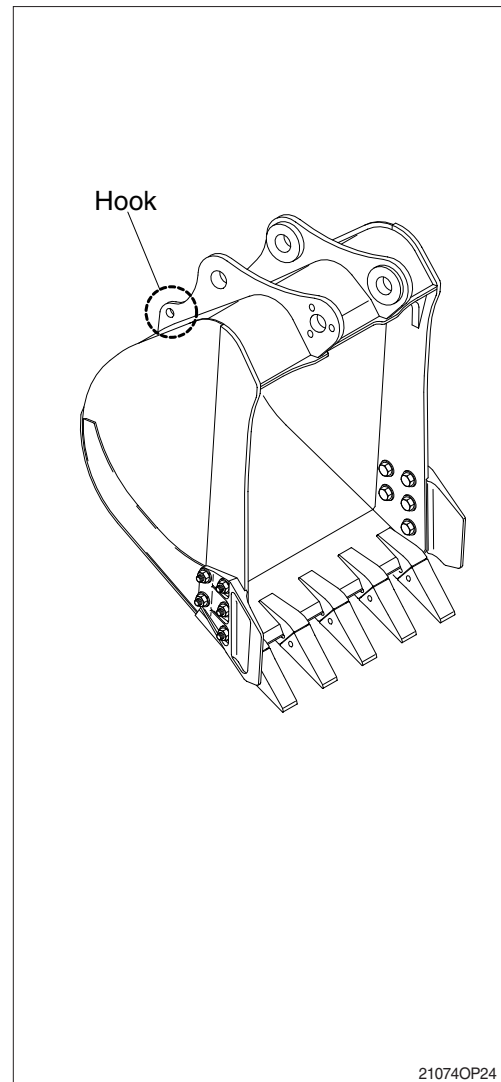

## 8. OPERATION IN THE SPECIAL WORK SITES

### 1) OPERATION THE MACHINE IN A COLD WEATHER

- (1) Use proper engine oil and fuel for the weather.
- (2) Fill the required amount of antifreeze in the coolant.
- (3) Refer to the starting engine in cold weather.  
Start the engine and extend the warming up operation.
- (4) Be sure to open the heater cock when using the heater.
- (5) Always keep the battery completely charged.  
※ **Discharged batteries will freeze more easily than fully charged.**
- (6) Clean the machine and park on the wood plates.

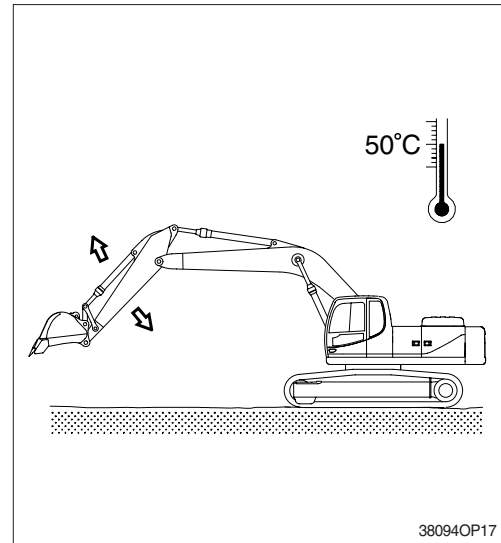

### 2) OPERATION IN SANDY OR DUSTY WORK SITES

- (1) Inspect air cleaner element frequently. Clean or replace element more frequently, if warning lamp comes ON and buzzer sounds simultaneously, regardless of inspection period.  
※ **Replace the inner and outer element after 4 times of cleaning.**
- (2) Inspect radiator, oil cooler and condenser frequently, and keep cooling fins clean.
- (3) Prevent sand or dust from getting into fuel tank and hydraulic tank during refilling.
- (4) Prevent sand or dust from penetrating into hydraulic circuit by tightly closing breather cap of hydraulic oil tank. Replace hydraulic oil filter and air breather element frequently. Also, replace the fuel filter frequently.
- (5) Keep all lubricated part, such as pins and bushings, clean at all times.
- (6) If the air conditioner and heater filters clogged, the heating or cooling capacity will drop. Clean or replace the filter element more frequently.
- (7) Clean electrical components, especially the starting motor and alternator to avoid accumulation of dust.

### **3) SEA SHORE OPERATION**

- (1) Prevent ingress of salt by securely tightening plugs, cocks and bolts of each part.
- (2) Wash machine after operation to remove salt residue.  
Pay special attention to electrical parts, and hydraulic cylinders and track tension cylinder to prevent corrosion.
- (3) Inspection and lubrication must be carried out more frequently.  
Supply sufficient grease to replace all old grease in bearings which have been submerged in water for a long time.

### **4) OPERATION IN MUD, WATER OR RAIN WORK SITES**

- (1) Perform a walk around inspection to check for any loose fittings, obvious damage to the machine or any fluid leakage.
- (2) After completing operations, clean mud, rocks or debris from the machine. Inspect for damage, cracked welds or loosened parts.
- (3) Perform all daily lubrication and service.
- (4) If the operations were in salt water or other corrosive materials, make sure to flush the affected equipment with fresh water.

### **5) OPERATION IN ROCKY WORK SITES**

- (1) Check for damage to the undercarriage and for looseness, flaws, wear and damage in bolts and nut.
- (2) Loosen the track tension a little when working in such areas.
- (3) Do not turn the undercarriage directly over the sharp edge rock.

## 9. NORMAL OPERATION OF EXCAVATOR

Followings may occur during operation due to the nature of a hydraulic excavator.

- 1) When rolling in the arm, the roll-in movement stop momentary at point X in the picture shown, then recovers speed again after passing point X.  
The reason for this phenomenon is that movement by the arm weight is faster than the speed of oil flow into the cylinder.
- 2) When lowering the boom, one may hear continuous sound.  
This is caused by oil flow in the valve.
- 3) Overloaded movement will produce sound caused by the relief valves, which are for the protection of the hydraulic systems.
- 4) When the machine is started swing or stopped, a noise near the swing motor may be heard. The noise is generated when the brake valve relieves.

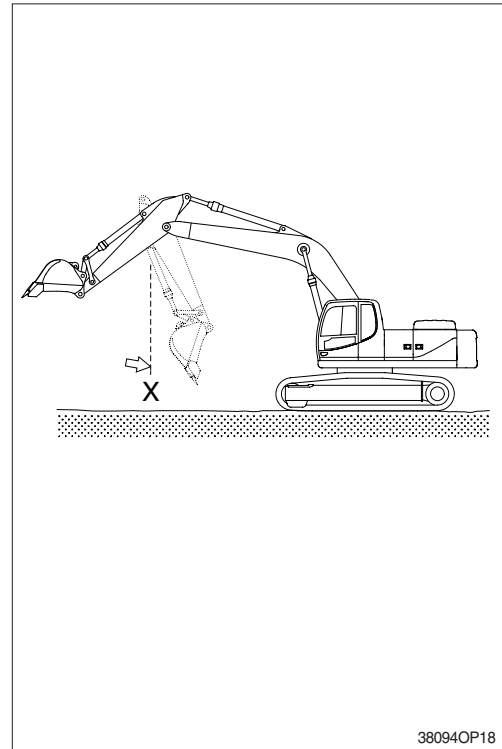

## 10. ATTACHMENT LOWERING (when engine is stopped)

1) On machines equipped with an accumulator, for a short time (within 1 minute) after the engine is stopped, the attachment will lower under its own weight when the attachment control lever is shifted to LOWER. That is happen only starting switch ON position and safety lever UNLOCK position. After the engine is stopped, set the safety lever to the LOCK position.

**▲ Be sure no one is under or near the attachment before lowering the boom.**

2) The accumulator is filled with high-pressure nitrogen gas, and it is extremely dangerous if it is handled in the wrong way. Always observe the following precautions.

**▲ Never make any hole in the accumulator expose it to flame or fire.**

**▲ Do not weld anything to the accumulator.**

**※ When carrying out disassembly or maintenance of the accumulator, or when disposing of the accumulator, it is necessary to release the gas from the accumulator. A special air bleed valve is necessary for this operation, so please contact your Hyundai distributor.**

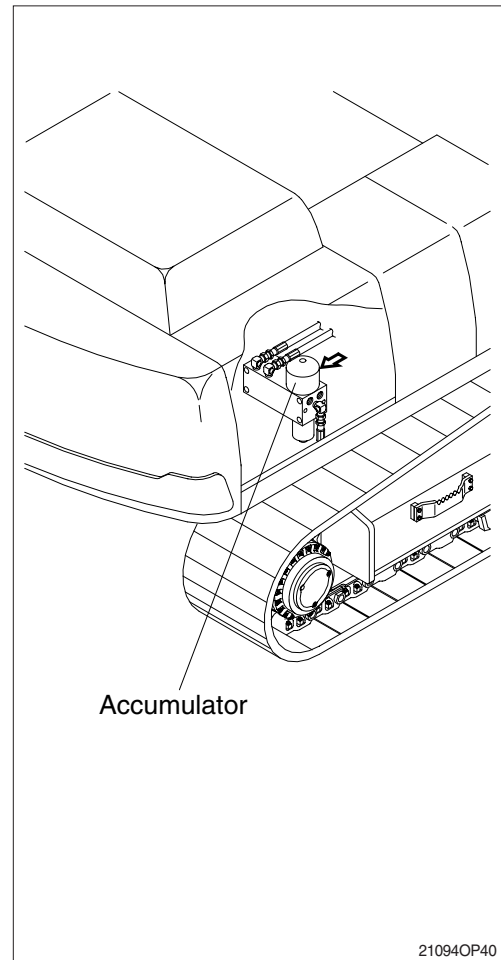

21094OP40



## 11. STORAGE

Maintain the machine taking care of following to prevent the deterioration of machine when storing the machine for a long time, over 1 month.

### 1) BEFORE STORAGE

#### (1) Cleaning the machine

Clean the machine. Check and adjust tracks.  
Grease each lubrication part.

#### (2) Lubrication position of each part

Change all oil.

※ **Be particularly careful when you reuse the machine.**

**As oil can be diluted during storage.**

**Apply an anticorrosive lubricant on the exposed part of piston rod of cylinder and in places where the machine rusts easily.**

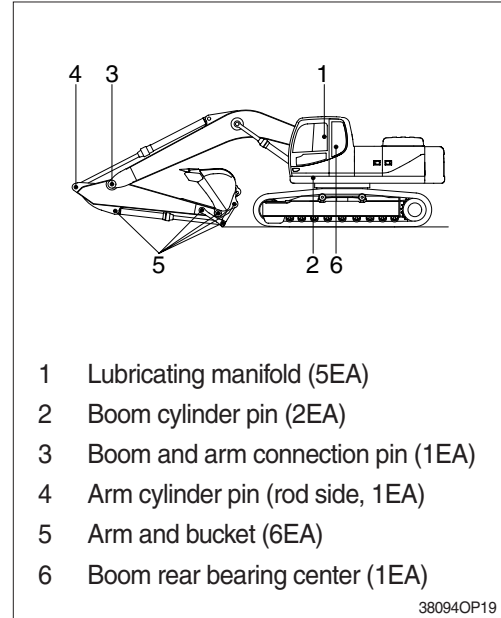

#### (3) Master switch

Turn OFF the master switch mounted electric box and store the machine.

(4) Be sure to mix anticorrosive antifreezing solution in the radiator.

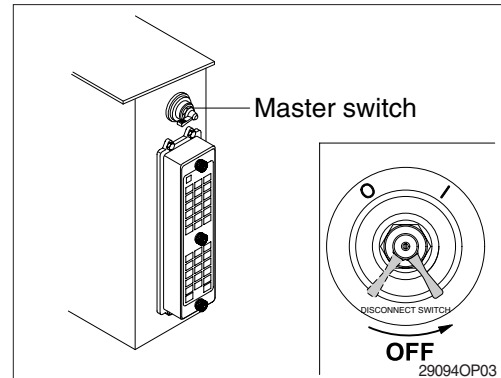

#### (5) Prevention of dust and moisture

Keep machine dry. Store the machine setting wood on the ground.

- ※ **Cover exposed part of piston rod of cylinder.**
- ※ **Lower the bucket to the ground and set a support under track.**

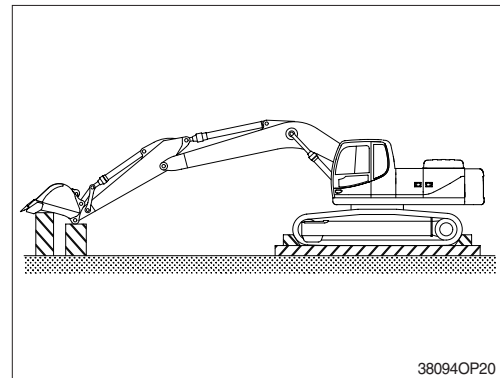

## 2) DURING STORAGE

Start engine and move the machine and work equipment once a month and apply lubrication to each part.

- ※ Check the level of engine oil and coolant and fill if required when starting engine.
- ※ Clean the anticorrosive on the piston rod of cylinder.
- ※ Operate the machine such as traveling, swing and work equipment operation to make sure enough lubrication of all functional components.

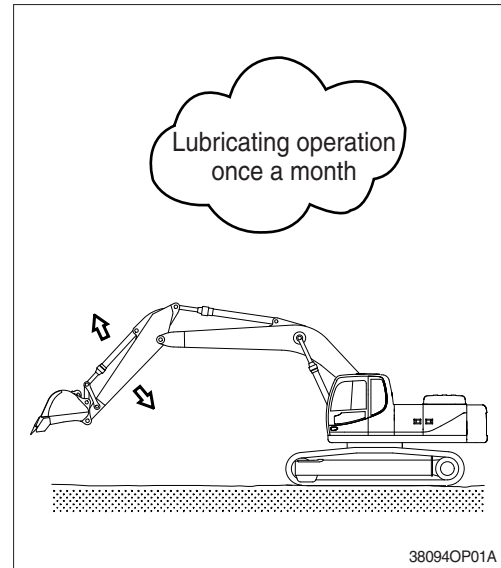

### ※ BATTERY

- ① Once a month, start the engine for 15 minutes (or use a charger) to charge the battery.
- ② Every 2 months, check the battery voltage and keep battery voltage over 25.08V.
- ③ If the machine stock period is over 6 months, disconnect the battery negative (-) terminal.

## 3) AFTER STORAGE

Carry out the following procedure when taking out of a long time storage.

- (1) Wipe off the anticorrosive lubricant on the hydraulic piston rod.
- (2) Completely fill fuel tank, lubricate and add oil.

### (3) When storage period is 6 months over

If the machine stock period is over 6 months, carry out the following procedure.

This procedure is to drain condensation water for the **swing reduction gear** durability.

- ※ Remove the drain port plug and drain the water until the gear oil comes out and then tighten the drain plug.
- ※ Refer to the service instruction, section 6 for the drain plug location.
- ※ If the machine is stored without carrying out the monthly lubricating operation, consult your Hyundai dealer for service.

## 12. RCV LEVER OPERATING PATTERN

### 1) PATTERN CHANGE VALVE NOT INSTALL (standard)

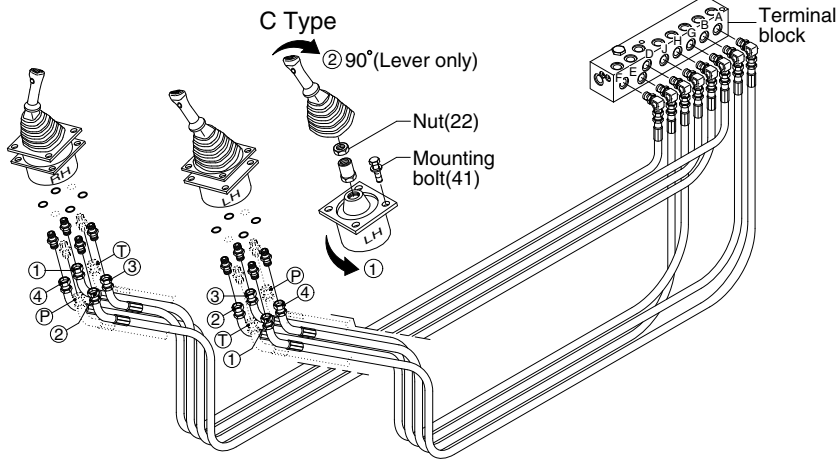

※ Whenever a change is made to the machine control pattern also exchange the pattern label in the cab to match the new pattern.

※ The hose modification works must be carried out between RCV lever and terminal block (Not between terminal block and MCV).

3809A4OP22

Pattern	Operation		Control function	Hose connection (port)			
	Left RCV lever	Right RCV lever		RCV lever	Change of Terminal block		
					From	To	
ISO Type			Left	1 Arm out	②	D	-
				2 Arm in	④	E	-
				3 Swing right	③	B	-
				4 Swing left	①	A	-
	Right	5 Boom lower	④	J	-		
		6 Boom raise	②	H	-		
		7 Bucket out	①	G	-		
		8 Bucket in	③	F	-		
Hyundai			Left	1 Boom lower	②	D	J
				2 Boom raise	④	E	H
				3 Swing right	③	B	-
				4 Swing left	①	A	-
	Right	5 Arm out	④	J	D		
		6 Arm in	②	H	E		
		7 Bucket out	①	G	-		
		8 Bucket in	③	F	-		
A Type			Left	1 Boom lower	②	D	J
				2 Boom raise	④	E	H
				3 Swing right	③	B	-
				4 Swing left	①	A	-
	Right	5 Arm out	④	J	D		
		6 Arm in	②	H	E		
		7 Bucket out	①	G	-		
		8 Bucket in	③	F	-		
B Type			Left	1 Boom lower	②	D	J
				2 Boom raise	④	E	H
				3 Bucket in	③	B	F
				4 Bucket out	①	A	G
	Right	5 Arm out	④	J	D		
		6 Arm in	②	H	E		
		7 Swing right	①	G	B		
		8 Swing left	③	F	A		
C Type			Left	① Loosen the RCV lever mounting bolt (41) and rotates lever assy 90° counterclockwise; then install. ② To put lever in correct position, disassemble nut (22) and rotates only lever 90° clockwise.			
			Right	Same as ISO type			

## 2) PATTERN CHANGE VALVE INSTALL (option)

※ If the machine is equipped with the pattern change valve, the machine operation pattern can be easily changed.

※ Whenever a change is made to the machine control pattern also exchange the pattern label in the cab to match the new pattern.

Operation	ISO type	A type
Left RCV lever		
Right RCV lever		

(1) The machine control pattern can be easily changed from the "ISO type" to "A type" by changing the position of the lever position.

▲ Before starting the machine, check the lever position of pattern change valve and actual operating of attachment.

### (2) Change of operating pattern

- ① Loosen bolt.
- ② Move lever to the "ISO" or "A" position.
- ③ After the lever is set, tighten the bolt in order to secure the lever.
  - Position ① for "ISO" pattern.
  - Position ② for "A" pattern.

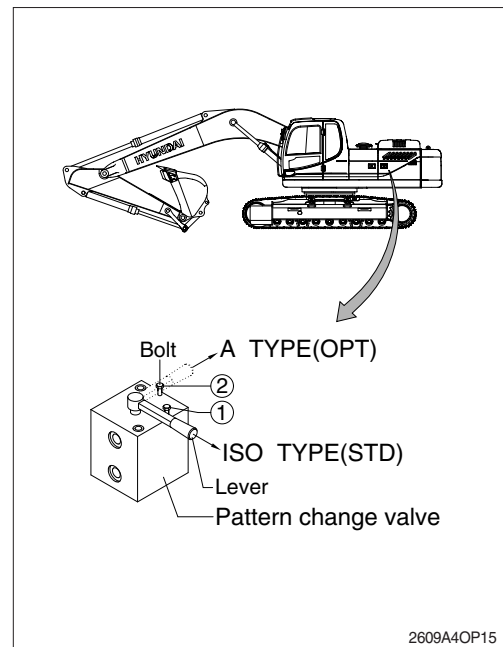

### 13. SWITCHING HYDRAULIC ATTACHMENT CIRCUIT

- 1) The combined hydraulic attachment circuit is capable of providing single action or double action.
- 2) The position of 3 way valve selects the single action hydraulic attachment circuit or the double action hydraulic attachment circuit.
- 3) Before you change the flow mode of hydraulic attachment circuit, place the machine in the servicing position as shown. Stop the engine.

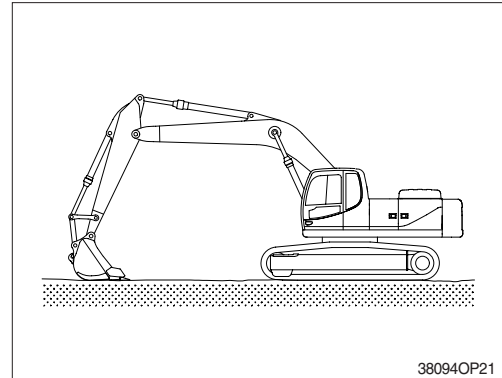

- 4) Use the spanner to turn the bolt of 3 way valve. Make sure that you turn the bolt between (b) and (c).

**(1) One way flow** (hydraulic breaker)

Position the groove parallel to the piping (b).

**(2) Two way flow** (clamshell or shear)

Position the groove perpendicular to the piping (c).

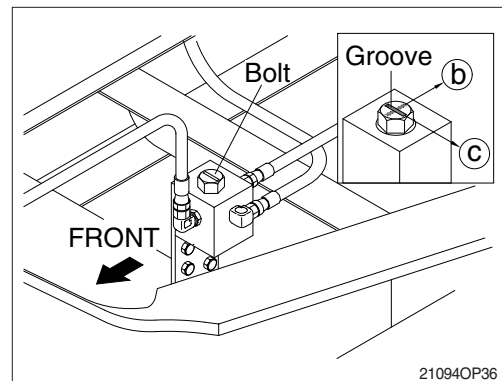

## 14. REGENERATION SYSTEM

### Regeneration

Particulate matter (mainly soot) filtered in DPF (diesel particulate filter) occurs poor performance caused by increasing exhaust gas pressure, incinerating process to convert from accumulated soot to ash is required. This process named regeneration.

The type of regeneration composes of automatic regeneration (active, auto-play by exhaust gas heat) and manual regeneration (passive play by the artificial aid).

- ▲ **Regeneration generates hot exhaust and causes hot exhaust system components.**
- ▲ **Exhaust system components get very hot and can cause severe burns. Risk for fire.**
- ▲ **Do not touch the surface of the DPF muffler during or up to 30 minutes after operation.**
- ▲ **Do not perform regeneration in a flammable environment.**

#### (1) DPF warning lamp

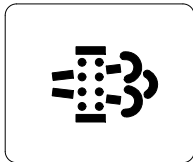

2609A3CD19

This warning lamp will light ON or blink when regeneration is needed.

- ※ **Refer to the page 3-6 for details.**
- ※ **The machine must be in a fireproof area during the entire regeneration process.**

#### (2) DPF regeneration inhibit warning lamp

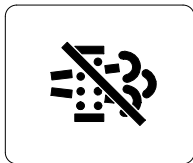

2609A3CD20

This warning lamp will light ON when the DPF switch is pushed inhibit position.

- ※ **Refer to the page 3-8 for details.**

#### (3) HEST(high exhaust system temperature) warning lamp

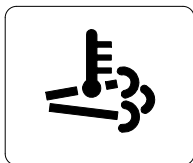

2609A3CD21

This warning lamp will light ON when the exhaust temperatures are high due to regeneration of the DPF.

- ※ **Refer to the page 3-7 for details.**

#### (4) DPF switch

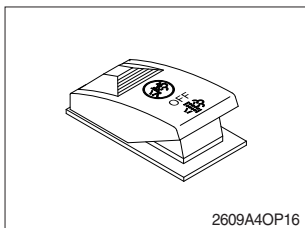

2609A4OP16

This switch is used to select the regeneration function of the DPF.

- ※ **Refer to the page 3-31 for details.**
- ※ **Manual regeneration : refer to the page 3-7 for details.**

#### (5) DPF cleaning

Every 5000 hours.

- ※ **Refer to the page 6-33 for details.**

# TRANSPORTATION

## 1. PREPARATION FOR TRANSPORTATION

- 1) When transporting the machine, observe the various road rules, road transportation vehicle laws and vehicle limit ordinances, etc.
- 2) Select proper trailer after confirming the weight and dimension from the chapter 2, specification.
- 3) Check the whole route such as the road width, the height of bridge and limit of weight and etc., which will be passed.
- 4) Get the permission from the related authority if necessary.
- 5) Prepare suitable capacity of trailer to support the machine.
- 6) Prepare gangplank for safe loading referring to the below table and illustration.

A	B
1.0	3.65 ~ 3.85
1.1	4.00 ~ 4.25
1.2	4.35 ~ 4.60
1.3	4.75 ~ 5.00
1.4	5.10 ~ 5.40
1.5	5.50 ~ 5.75

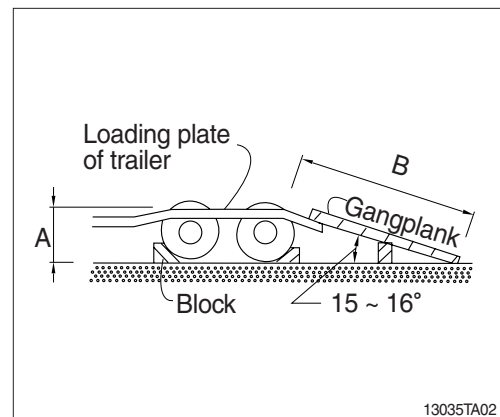
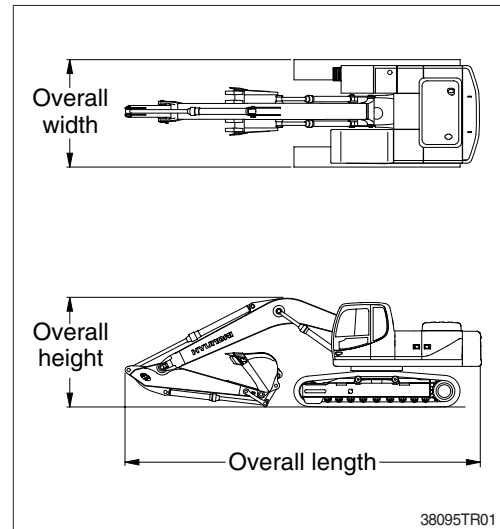

## 2. DIMENSION AND WEIGHT

### 1) BASE MACHINE

Mark	Description	Unit	Specification
L	Length	mm (ft-in)	6240 (20' 6")
H	Height	mm (ft-in)	3180 (10' 5")
W	Width	mm (ft-in)	3340 (10' 11")
Wt	Weight	kg (lb)	35690 (78680)

※ With 600 mm (24") triple grouser shoes.

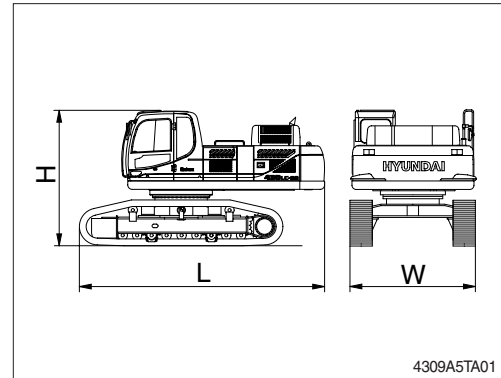

4309A5TA01

### 2) BOOM ASSEMBLY

Mark	Description	Unit	Specification
L	Length	mm (ft-in)	6730 (22' 1")
H	Height	mm (ft-in)	1760 ( 5' 9")
W	Width	mm (ft-in)	830 ( 2' 9")
Wt	Weight	kg (lb)	3900 (8600)

※ 6.5 m (21' 4") boom with arm cylinder (included piping and pins).

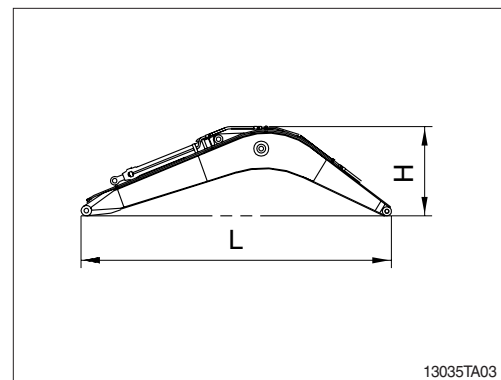

13035TA03

### 3) ARM ASSEMBLY

Mark	Description	Unit	Specification
L	Length	mm (ft-in)	3760 (12' 4")
H	Height	mm (ft-in)	1250 ( 4' 1")
W	Width	mm (ft-in)	430 ( 1' 5")
Wt	Weight	kg (lb)	2030 (4480)

※ 2.6 m (8' 6") arm with bucket cylinder (included linkage and pins).

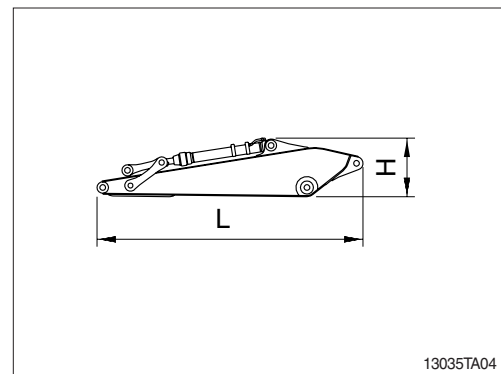

13035TA04

### 4) BUCKET ASSEMBLY

Mark	Description	Unit	Specification
L	Length	mm (ft-in)	1880 (6' 2")
H	Height	mm (ft-in)	1385 (4' 7")
W	Width	mm (ft-in)	1800 (5' 11")
Wt	Weight	kg (lb)	2090 (4610)

※ 2.10 m<sup>3</sup> (2.75 yd<sup>3</sup>) SAE heaped bucket (included tooth and side cutters).

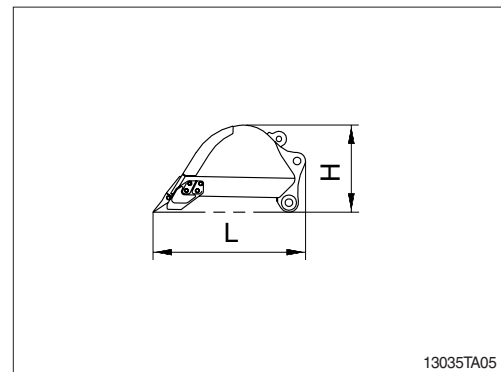

13035TA05



### 5) BOOM CYLINDER

Mark	Description	Unit	Specification
L	Length	mm (ft-in)	2300 (7' 7")
H	Height	mm (ft-in)	350 (1' 2")
W	Width	mm (ft-in)	425 (1' 5")
Wt	Weight	kg (lb)	740 (1630)

※ Included piping.

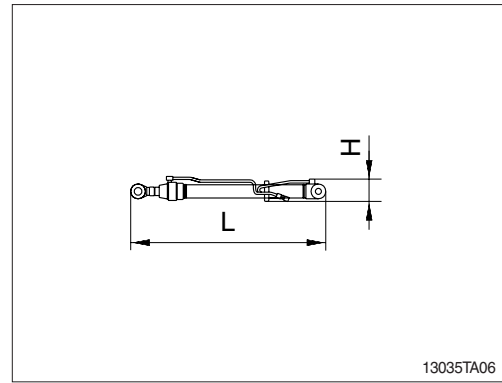

### 6) CAB ASSEMBLY

Mark	Description	Unit	Specification
L	Length	mm (ft-in)	1962 (6' 4")
H	Height	mm (ft-in)	1686 (5' 6")
W	Width	mm (ft-in)	1000 (3' 3")
Wt	Weight	kg (lb)	490 (1080)

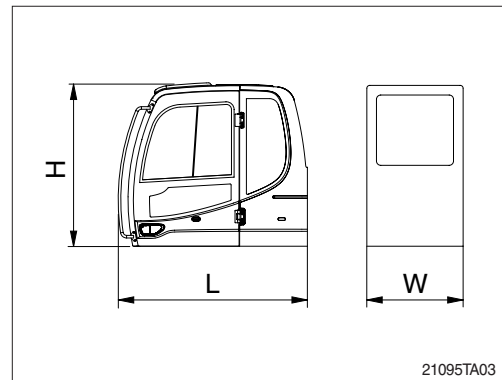

### 7) COUNTERWEIGHT

Mark	Description	Unit	Specification
L	Length	mm (ft-in)	2980 (9' 9")
H	Height	mm (ft-in)	1150 (3' 9")
W	Width	mm (ft-in)	590 (1' 11")
Wt	Weight	kg (lb)	7500 (16540)

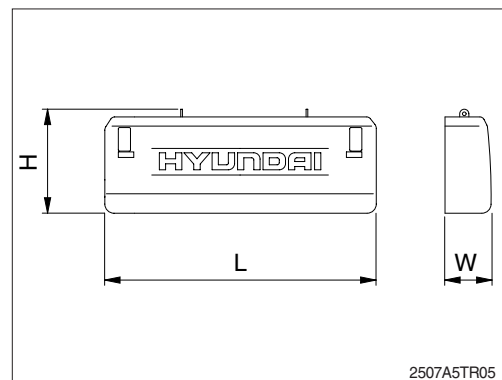

### 3. LOADING THE MACHINE

- 1) Load and unload the machine on a flat ground.
- 2) Use the gangplank with sufficient length, width, thickness and gradient.
- 3) Place the safety lever to the LOCK position (if equipped) before fixing the machine at the bed of trailer and confirm if the machine parallels the bed of trailer.  
Keep the travel motor in the rear when loading and in the front when unloading.

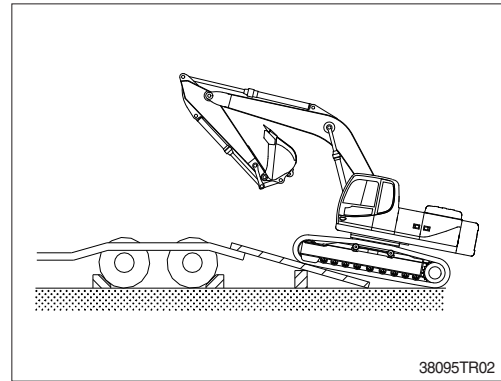

- 4) Do the following after loading the machine to the trailer.
  - (1) Stop loading when the machine is located horizontally with the rear wheel of trailer.

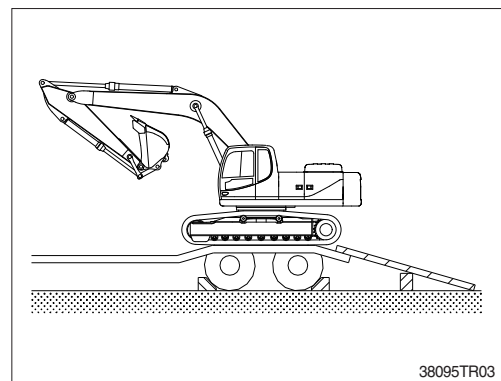

- (2) Place the safety lever to the LOCK position (if equipped) after the swing the machine 180 degree.

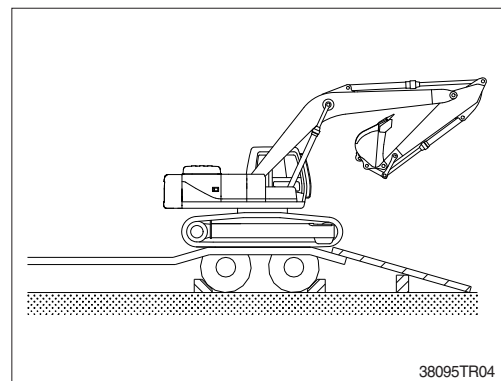

- (3) Lower the working equipment gently after the location is determined.
- ※ Place rectangular timber under the bucket cylinder to prevent the damage of it during transportation.
  - ▲ Be sure to keep the travel speed switch on the LOW (turtle mark) while loading and unloading the machine.
  - ▲ Avoid using the working equipment for loading and unloading since it will be very dangerous.
  - ▲ Do not operate any other device when loading.
  - ▲ Be careful on the boundary place of loading plate or trailer as the balance of machine will abruptly be changed on the point.

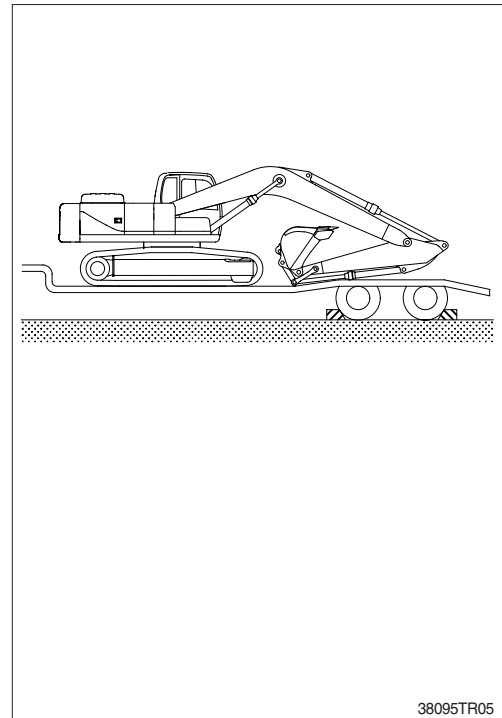

## 4. FIXING THE MACHINE

- 1) Lower down the working device on the loading plate of trailer.
- 2) Keep the safety lever on the LOCK position.
- 3) Turn OFF all the switches and remove the key.

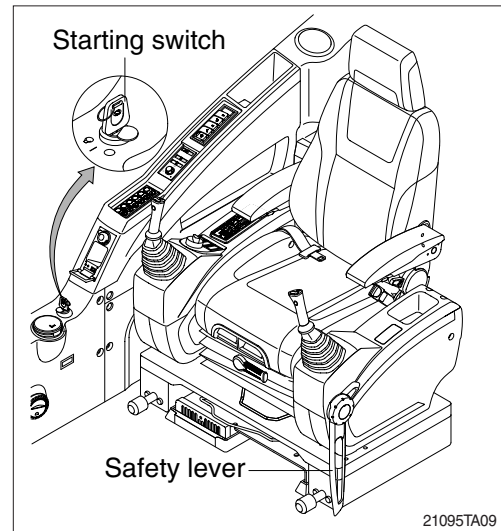

- 4) Secure all locks.

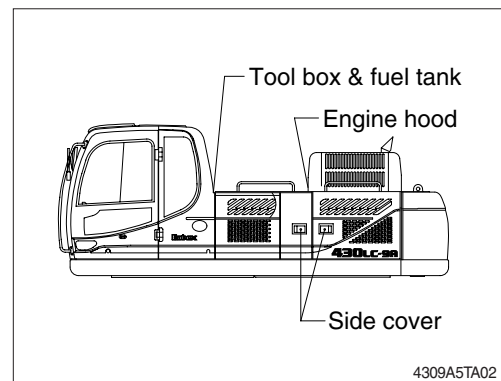

- 5) Place timber underneath of the track and fix firmly with wire rope to prevent the machine from moving forward, backward, right or left.

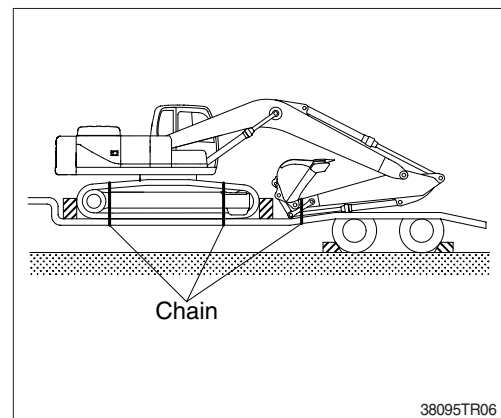

## 5. LOADING AND UNLOADING BY CRANE

- 1) Check the weight, length, width and height of the machine referring to the chapter 2, specification when you are going to hoist the machine.
- 2) Use long wire rope and stay to keep the distance with the machine as it should avoid touching with the machine.
- 3) Put a rubber plate contact with wire rope and machine to prevent damage.
- 4) Place crane on the proper place.
- 5) Install the wire rope and stay like the illustration.

- ▲ **Make sure wire rope is proper size.**
- ▲ **Place the safety lever to LOCK position to prevent the machine moving when hoisting the machine.**
- ▲ **The wrong hoisting method or installation of wire rope can cause damage to the machine.**
- ▲ **Do not load abruptly.**
- ▲ **Keep area clear of personnel.**

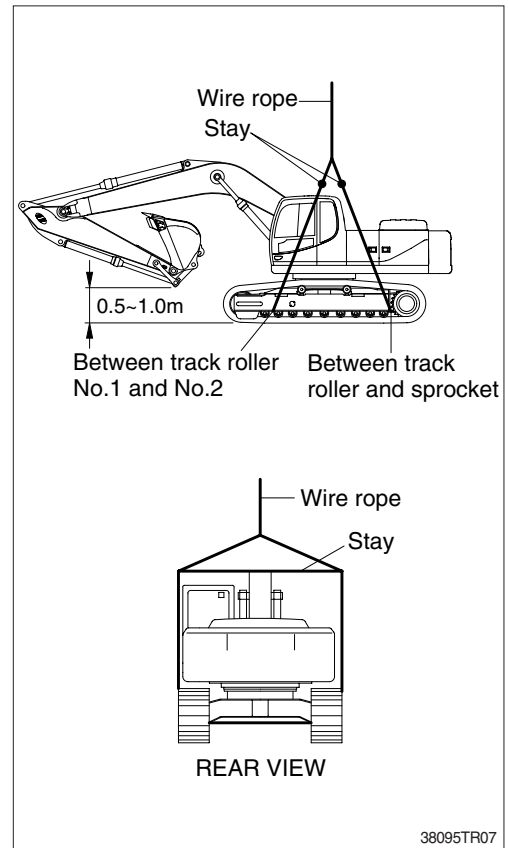

## 1. INSTRUCTION

### 1) INTERVAL OF MAINTENANCE

- (1) You may inspect and service the machine by the period as described at page 6-11 based on hour meter at control panel.
- (2) Shorten the interval of inspect and service depending on site condition. (such as dusty area, quarry, sea shore and etc.)
- (3) Practice the entire related details at the same time when the service interval is doubled.  
For example, in case of 100hours, carry out all the maintenance 「Each 100hours, each 50 hours and daily service」 at the same time.

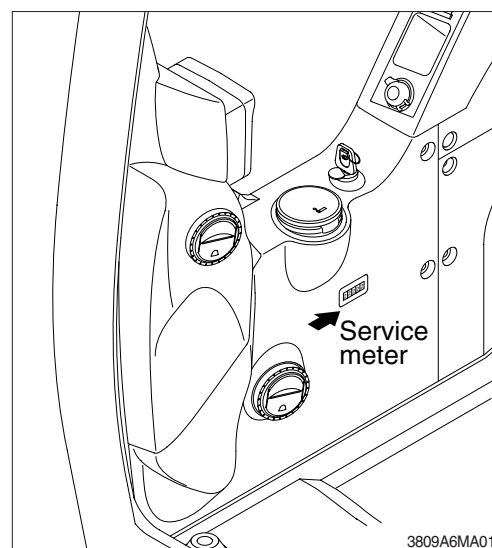

### 2) PRECAUTION

- (1) Start to maintenance after you have the full knowledge of machine.
- (2) The monitor installed on this machine does not entirely guarantee the condition of the machine.  
Daily inspection should be performed according to clause 4, maintenance check list.
- (3) Engine and hydraulic components have been preset in the factory.  
Do not allow unauthorized personnel to reset them.
- (4) Ask to your local dealer or Hyundai for the maintenance advice if unknown.
- (5) Drain the used oil and coolant in a container and handle according to the method of handling for industrial waste to meet with regulations of each province or country.

### 3) PROPER MAINTENANCE

#### (1) Replace and repair of parts

It is required to replace the wearable and consumable parts such as bucket tooth, side cutter, filter and etc., regularly.

Replace damaged or worn parts at proper time to keep the performance of machine.

- (2) Use genuine parts.
  - (3) Use the recommended oil.
  - (4) Remove the dust or water around the inlet of oil tank before supplying oil.
  - (5) Drain oil when the temperature of oil is warm.
  - (6) Do not repair anything while operating the engine.  
Stop the engine when you fill the oil.
  - (7) Relieve hydraulic system of the pressure before repairing the hydraulic system.
  - (8) Confirm if the cluster is in the normal condition after completion of service.
  - (9) For more detail information of maintenance, please contact local Hyundai dealer.
- ※ **Be sure to start the maintenance after fully understand the chapter 1, safety hints.**

#### 4) RELIEVING THE PRESSURE IN THE HYDRAULIC SYSTEM

※ Spouting of oil can cause the accident when loosening the cap or hose right after the operating of machine as the machine or oil is on the high pressure on the condition. Be sure to relieve the pressure in the system before repairing hydraulic system.

- (1) Place machine in parking position, and stop the engine.

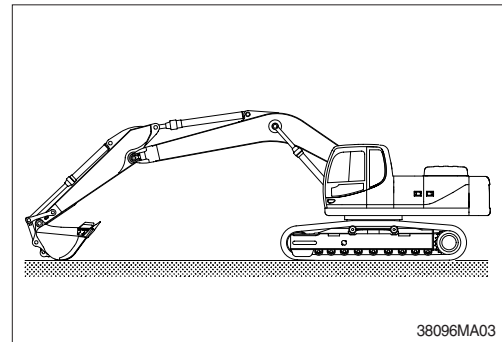

- (2) Set the safety lever completely in the release position, operate the control levers and pedals fully to the front, rear, left and right, to release the pressure in the hydraulic circuit.

※ **This does not completely release the pressure, so when serving hydraulic component, loosen the connections slowly and do not stand in the direction where the oil spurt out.**

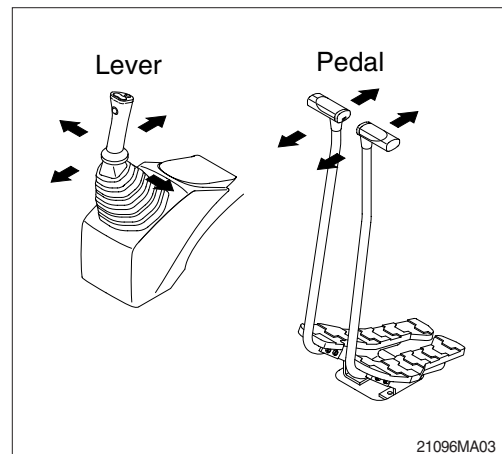

- (3) Loosen the cap and relieve the pressure in the tank by pushing the top of the air breather.

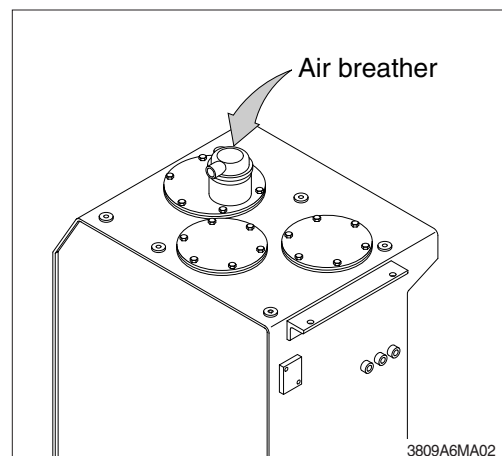



## 5) PRECAUTION WHEN INSTALLING HYDRAULIC HOSES OR PIPES

- (1) Be particularly careful that the joint of hose, pipe and functioning item are not damaged.  
Avoid contamination.
- (2) Assemble after cleaning the hose, pipe and joint of functioning item.
- (3) Use genuine parts.
- (4) Do not assemble the hose in the condition of twisted or sharp radius.
- (5) Keep the specified tighten torque.

## 6) PERIODICAL REPLACEMENT OF SAFETY PARTS

(1) It is desirable to do periodic maintenance the machine for using the machine safely for a long time.

However, recommend to replace regularly the parts related safety not only safety but maintain satisfied performance.

(2) These parts can cause the disaster of life and material as the quality changes by passing time and it is worn, diluted, and gets fatigued by using repeatedly.

These are the parts which the operator can not judge the remained lifetime of them by visual inspection.

(3) Repair or replace if an abnormality of these parts is found even before the recommended replacement interval.

Periodical replacement of safety parts			Interval
Engine		Fuel hose (tank-engine)	Every 2 years
		Heater hose (heater-engine)	
Hydraulic system	Main circuit	Pump suction hose	Every 2 years
		Pump delivery hose	
		Swing hose	
	Working device	Boom cylinder line hose	Every 2 years
		Arm cylinder line hose	
		Bucket cylinder line hose	

※ 1. Replace O-ring and gasket at the same time when replacing the hose.

2. Replace clamp at the same time if the hose clamp is cracked when checking and replacing the hose.

## 2. TIGHTENING TORQUE

Use following table for unspecified torque.

### 1) BOLT AND NUT

#### (1) Coarse thread

Bolt size	8T		10T	
	kg · m	lb · ft	kg · m	lb · ft
M 6 × 1.0	0.85 ~ 1.25	6.15 ~ 9.04	1.14 ~ 1.74	8.2 ~ 12.6
M 8 × 1.25	2.0 ~ 3.0	14.5 ~ 21.7	2.7 ~ 4.1	19.5 ~ 29.7
M10 × 1.5	4.0 ~ 6.0	28.9 ~ 43.4	5.5 ~ 8.3	39.8 ~ 60
M12 × 1.75	7.4 ~ 11.2	53.5 ~ 81.0	9.8 ~ 15.8	70.9 ~ 114
M14 × 2.0	12.2 ~ 16.6	88.2 ~ 120	16.7 ~ 22.5	121 ~ 163
M16 × 2.0	18.6 ~ 25.2	135 ~ 182	25.2 ~ 34.2	182 ~ 247
M18 × 2.5	25.8 ~ 35.0	187 ~ 253	35.1 ~ 47.5	254 ~ 344
M20 × 2.5	36.2 ~ 49.0	262 ~ 354	49.2 ~ 66.6	356 ~ 482
M22 × 2.5	48.3 ~ 63.3	349 ~ 458	65.8 ~ 98.0	476 ~ 709
M24 × 3.0	62.5 ~ 84.5	452 ~ 611	85.0 ~ 115	615 ~ 832
M30 × 3.0	124 ~ 168	898 ~ 1214	169 ~ 229	1223 ~ 1656
M36 × 4.0	174 ~ 236	1261 ~ 1704	250 ~ 310	1808 ~ 2242

#### (2) Fine thread

Bolt size	8T		10T	
	kg · m	lb · ft	kg · m	lb · ft
M 8 × 1.0	2.2 ~ 3.4	15.9 ~ 24.6	3.0 ~ 4.4	21.7 ~ 31.8
M10 × 1.2	4.5 ~ 6.7	32.5 ~ 48.5	5.9 ~ 8.9	42.7 ~ 64.4
M12 × 1.25	7.8 ~ 11.6	56.4 ~ 83.9	10.6 ~ 16.0	76.7 ~ 116
M14 × 1.5	13.3 ~ 18.1	96.2 ~ 131	17.9 ~ 24.1	130 ~ 174
M16 × 1.5	19.9 ~ 26.9	144 ~ 195	26.6 ~ 36.0	192 ~ 260
M18 × 1.5	28.6 ~ 43.6	207 ~ 315	38.4 ~ 52.0	278 ~ 376
M20 × 1.5	40.0 ~ 54.0	289 ~ 391	53.4 ~ 72.2	386 ~ 522
M22 × 1.5	52.7 ~ 71.3	381 ~ 516	70.7 ~ 95.7	511 ~ 692
M24 × 2.0	67.9 ~ 91.9	491 ~ 665	90.9 ~ 123	658 ~ 890
M30 × 2.0	137 ~ 185	990 ~ 1339	182 ~ 248	1314 ~ 1796
M36 × 3.0	192 ~ 260	1390 ~ 1880	262 ~ 354	1894 ~ 2562

**2) PIPE AND HOSE (FLARE type)**

Thread size (PF)	Width across flat (mm)	kgf · m	lbf · ft
1/4"	19	4	28.9
3/8"	22	5	36.2
1/2"	27	9.5	68.7
3/4"	36	18	130
1"	41	21	152
1-1/4"	50	35	253

**3) PIPE AND HOSE (ORFS type)**

Thread size (UNF)	Width across flat (mm)	kgf · m	lbf · ft
9/16-18	19	4	28.9
11/16-16	22	5	36.2
13/16-16	27	9.5	68.7
1-3/16-12	36	18	130
1-7/16-12	41	21	152
1-11/16-12	50	35	253

**4) FITTING**

Thread size	Width across flat (mm)	kgf · m	lbf · ft
1/4"	19	4	28.9
3/8"	22	5	36.2
1/2"	27	9.5	68.7
3/4"	36	18	130
1"	41	21	152
1-1/4"	50	35	253

#### 4) TIGHTENING TORQUE OF MAJOR COMPONENT

No.	Descriptions	Bolt size	Torque		
			kgf · m	lbf · ft	
1	Engine	Engine mounting bolt (bracket-frame)	M24 × 3.0	90 ± 7.0	651 ± 51
2		Engine mounting bolt (engine-bracket)	M12 × 1.75	12.8 ± 3.0	92.6 ± 21.7
3		Radiator mounting bolt	M16 × 2.0	29.7 ± 4.5	215 ± 32.5
4		Coupling mounting socket bolt	M20 × 2.5	46.5 ± 2.5	336 ± 18.1
5		Main pump housing mounting bolt	M10 × 1.5	6.9 ± 1.4	49.9 ± 10.1
6	Hydraulic system	Main pump mounting socket bolt	M20 × 2.5	69.5 ± 10.4	503 ± 75.2
7		Main control valve mounting bolt	M16 × 2.0	29.7 ± 4.5	215 ± 32.5
8		Fuel tank mounting bolt	M20 × 2.5	46 ± 5.1	333 ± 36.9
9		Hydraulic oil tank mounting bolt	M20 × 2.5	46 ± 5.0	333 ± 36
10		Turning joint mounting bolt, nut	M12 × 1.75	12.3 ± 1.2	88.9 ± 8.7
11	Power train system	Swing motor mounting bolt	M24 × 3.0	97.8 ± 15	707 ± 108
12		Swing bearing upper part mounting bolt	M24 × 3.0	100 ± 10	723 ± 72.3
13		Swing bearing lower part mounting bolt	M24 × 3.0	100 ± 10	723 ± 72.3
14		Travel motor mounting bolt	M20 × 2.5	57.9 ± 8.7	419 ± 62.9
15		Sprocket mounting bolt	M20 × 2.5	57.9 ± 6.0	419 ± 43.4
16	Under carriage	Carrier roller mounting bolt, nut	M16 × 2.0	29.7 ± 3.0	215 ± 21.7
17		Track roller mounting bolt	M24 × 3.0	100 ± 10	723 ± 72.3
18		Track tension cylinder mounting bolt	M22 × 1.5	87.2 ± 12.5	631 ± 90.4
19		Track shoe mounting bolt, nut	M24 × 1.5	140 ± 14	1010 ± 101
20		Track guard mounting bolt	M24 × 3.0	77.4 ± 11	560 ± 79.6
21	Others	Counterweight mounting bolt	M36 × 3.0	337 ± 33	2440 ± 72.3
22		Cab mounting bolt	M12 × 1.75	12.8 ± 3.0	92.6 ± 21.7
23		Operator's seat mounting bolt	M 8 × 1.25	4.05 ± 0.8	29.3 ± 5.8

※ For tightening torque of engine and hydraulic components, see engine maintenance guide and service manual.

### 3. FUEL, COOLANT AND LUBRICANTS

#### 1) NEW MACHINE

New machine used and filled with following lubricants.

Description	Specification
Engine oil	SAE 10W-30 (API CJ-4)
Hydraulic oil	Hyundai genuine long life hydraulic oil (ISO VG 32, VG 46, VG 68) Conventional hydraulic oil (ISO VG 15, ★cold region )
Swing and travel reduction gear	SAE 80W-90 (API GL-5)
Grease	Lithium base grease NLGI No. 2
Fuel	ASTM D975-No. 2
Coolant (DCA4)	ASTM D6210 Mixture of 50% ethylene glycol base antifreeze and 50% water.

**SAE** : Society of Automotive Engineers

**API** : American Petroleum Institute

**ISO** : International Organization for Standardization

**NLGI** : National Lubricating Grease Institute

**ASTM** : American Society of Testing and Material

**DCA4** : Brand name of Chemical Additive

manufactured by the Cummins Fleetguard Co

**Ultra low sulfur diesel**

- sulfur content ≤ 15 ppm

★Cold region

Russia, CIS, Mongolia

## 2) RECOMMENDED OILS

Use only oils listed below. Do not mix different brand oil.

Please use HYUNDAI genuine oil and grease.

Service point	Kind of fluid	Capacity ℓ (U.S. gal)	Ambient temperature °C (°F)							
			-50 (-58)	-30 (-22)	-20 (-4)	-10 (14)	0 (32)	10 (50)	20 (68)	30 (86)
Engine oil pan	Engine oil	30 (7.9)	★SAE 5W-40				SAE 30			
			SAE 10W				SAE 10W-30			
			SAE 15W-40							
Swing drive	Gear oil	8.0 (2.1)	★SAE 75W-90							
Final drive		12×2 (3.2×2)	SAE 80W-90							
Hydraulic tank	Hydraulic oil	Tank : 210 (55.5) System : 410 (108.3)	★ISO VG 15				ISO VG 32			
			ISO VG 46				ISO VG 68			
Fuel tank	Diesel fuel★1	550 (145.3)	★ASTM D975 NO.1				ASTM D975 NO.2			
Fitting (grease nipple)	Grease	As required	★NLGI NO.1				NLGI NO.2			
Radiator (reservoir tank)	Mixture of antifreeze and soft water★2	45 (13.7)	Ethylene glycol base permanent type (50 : 50)							
			★Ethylene glycol base permanent type (60 : 40)							

**SAE** : Society of Automotive Engineers

**API** : American Petroleum Institute

**ISO** : International Organization for Standardization

**NLGI** : National Lubricating Grease Institute

**ASTM** : American Society of Testing and Material

★ : Cold region

Russia, CIS, Mongolia

★1 : Ultra low sulfur diesel

- sulfur content ≤ 15 ppm

★2 : Soft water

City water or distilled water

## 4. MAINTENANCE CHECK LIST

### 1) DAILY SERVICE BEFORE STARTING

Check items	Service	Page
Visual check		
Fuel tank	Check, Refill	6-30
Hydraulic oil level	Check, Add	6-35
Engine oil level	Check, Add	6-18
Coolant level	Check, Add	6-21
Control panel & pilot lamp	Check, Clean	6-45
Prefilter	Check, Drain	6-32
Fan belt tension and damage	Check, Adjust	6-26
★ Attachment pin and bushing	Lubricate	6-44
· Boom cylinder tube end		
· Boom foot		
· Boom cylinder rod end		
· Arm cylinder tube end		
· Arm cylinder rod end		
· Boom + Arm connecting		
· Bucket cylinder tube end		

★ Lubricate every 10 hours or daily for initial 100 hours.

### 2) EVERY 50 HOURS SERVICE

Check items	Service	Page
Fuel tank (water, sediment)	Drain	6-30
Track tension	Check, Adjust	6-40
Swing reduction gear oil	Check, Add	6-38
Attachment pin and bushing	Lubricate	6-44
· Bucket cylinder rod end		
· Bucket + Arm connecting		
· Bucket control link + Arm		
· Bucket control rod		



### 3) INITIAL 50 HOURS SERVICE

Check items	Service	Page
Bolts & Nuts • Sprocket mounting bolts • Travel motor mounting bolts • Swing motor mounting bolts • Swing bearing mounting bolts • Engine mounting bolts • Counterweight mounting bolts • Turning joint locating bolts • Track shoe mounting bolts and nuts • Hydraulic pump mounting bolts	Check, Tight	6-8

※ **Service the above items only for the new machine, and thereafter keep the normal service interval.**

### 4) EVERY 200 HOURS SERVICE

Check items	Service	Page
★ Return filter	Replace	6-36
★ Pilot line filter	Replace	6-37
★ Drain filter cartridge	Replace	6-37

★ **Replace 3 filters for continuous hydraulic breaker operation only.**

### 5) INITIAL 250 HOURS SERVICE

Check items	Service	Page
Engine oil	Change	6-18, 19
Engine oil filter	Replace	6-18, 19
Prefilter (water, element)	Replace	6-31
Fuel filter	Replace	6-30
Pilot line filter	Replace	6-37
Hydraulic return filter	Replace	6-36
Drain filter cartridge	Replace	6-37
Swing reduction gear oil	Change	6-38
Swing reduction gear grease	Check, Add	6-38
Travel reduction gear oil	Change	6-39

## 6) EVERY 250 HOURS SERVICE

Check items	Service	Page
Battery (voltage)	Check, Clean	6-45
Swing bearing grease	Lubricate	6-38
Aircon & heater fresh air filter	Check, Clean	6-47
Air breather element	Replace	6-37
Bolts & Nuts	Check, Tight	6-8
<ul style="list-style-type: none"> <li>· Sprocket mounting bolts</li> <li>· Travel motor mounting bolts</li> <li>· Swing motor mounting bolts</li> <li>· Swing bearing mounting bolts</li> <li>· Engine mounting bolts</li> <li>· Counterweight mounting bolts</li> <li>· Turning joint locating bolts</li> <li>· Track shoe mounting bolts and nuts</li> <li>· Hydraulic pump mounting bolts</li> </ul>		
Attachment pin and bushing	Lubricate	6-43
<ul style="list-style-type: none"> <li>· Boom cylinder tube end</li> <li>· Boom foot</li> <li>· Boom cylinder rod end</li> <li>· Arm cylinder tube end</li> <li>· Arm cylinder rod end</li> <li>· Boom + Arm connecting</li> <li>· Bucket cylinder tube end</li> </ul>		

## 7) EVERY 500 HOURS SERVICE

Check items	Service	Page
★Engine oil	Change	6-18, 19
★Engine oil filter	Replace	6-18, 19
Water filter (corrosion resister)	Replace	6-20
Coolant test (DCA4 concentration)	Test, Add	6-21-1, 2
Radiator, cooler fin and charge air cooler	Check, Clean	6-25
Fuel filter element	Replace	6-30
Prefilter	Replace	6-32

★ If you use high sulfur containing fuel above than 0.5% or use low grade of engine oil reduce change interval.

### 8) EVERY 1000 HOURS SERVICE

Check items	Service	Page
Travel motor reduction gear oil	Change	6-39
Swing reduction gear oil	Change	6-38
Swing reduction gear grease	Check, Add	6-38
Grease in swing gear and pinion	Change	6-39
Hydraulic oil return filter	Replace	6-36
Drain filter cartridge	Replace	6-37
Pilot line filter	Replace	6-37
Air cleaner element (primary)	Check, Clean	6-29

### 9) EVERY 2000 HOURS SERVICE

Check items	Service	Page
Coolant	Change	6-21, 22, 23, 24
Hydraulic tank suction strainer	Check, Clean	6-36
Hydraulic oil * <sup>1</sup>	Change	6-35-1
Crankcase breather filter	Replace	6-33
Hoses, fittings, clamps (fuel, coolant, hydraulic)	Check, Retighten, Replace	-

\*<sup>1</sup> Conventional hydraulic oil

★ **Change oil every 600 hours of continuous hydraulic breaker operation.**

### 10) EVERY 4000 HOURS SERVICE

Check items	Service	Page
Air cleaner element (primary, safety)	Replace	6-29

### 11) EVERY 5000 HOURS SERVICE

Check items	Service	Page
Hydraulic oil * <sup>2</sup>	Change	6-35-1
DPF (diesel particulate filter)	Clean	6-33

\*<sup>2</sup> Hyundai genuine long life hydraulic oil

★ **Change oil every 1000 hours of continuous hydraulic breaker operation.**

## 12) WHEN REQUIRED

Whenever you have trouble in the machine, you must perform the service of related items, system by system.

Check items	Service	Page
Fuel system		
· Fuel tank	Drain or Clean	6-30
· Prefilter	Clean or Replace	6-32
· Fuel filter element	Replace	6-30
Engine lubrication system		
· Engine oil	Change	6-18, 19
· Engine oil filter	Replace	6-18, 19
Engine cooling system		
· Coolant	Add or Change	6-21, 22, 23, 24
· Radiator	Clean or Flush	6-21, 22, 23, 24
· Charge air cooler	Check	6-25
· Water filter (corrosion resister)	Replace	6-20
Engine air system		
· Air cleaner element (primary)	Clean or Replace	6-29
· Air cleaner element (safely)	Replace	6-29
Hydraulic system		
· Hydraulic oil	Add or Change	6-35, 35-1
· Return filter	Replace	6-36
· Drain line filter	Replace	6-37
· Pilot line filter	Replace	6-37
· Element of breather	Replace	6-37
· Suction strainer	Clean	6-36
Undercarriage		
· Track tension	Check, Adjust	6-40
Bucket		
· Tooth	Replace	6-42
· Side cutter	Replace	6-42
· Linkage	Adjust	6-41
· Bucket assy	Replace	6-41
Air conditioner and heater		
· Fresh air filter	Clean, Replace	6-48
· Recirculation filter	Clean	6-49

## 5. MAINTENANCE CHART

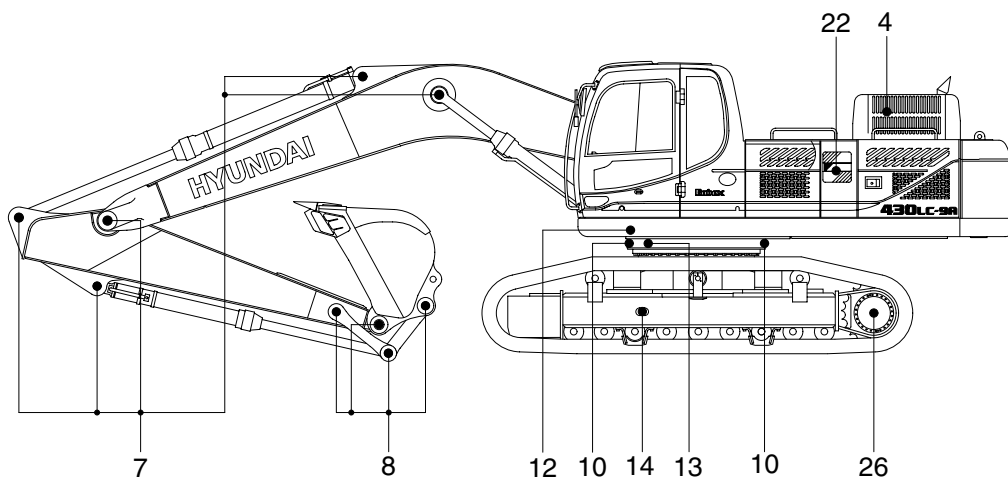
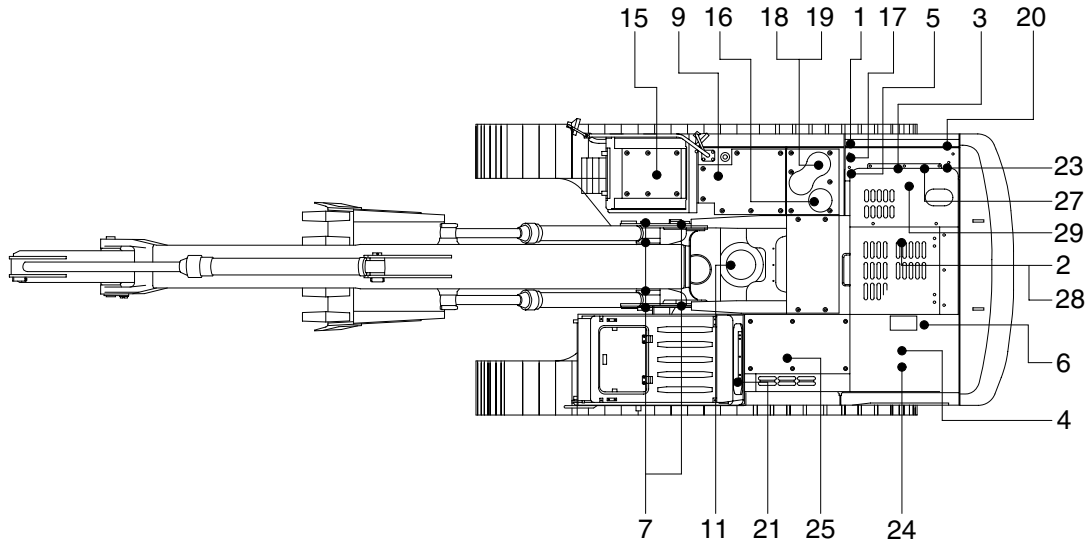

4309A6MA01

### Caution

1. Service intervals are based on the hour meter reading.
2. The number of each item shows the lubrication point on the machine.
3. Stop engine while filling oil, and use no open flames.

Service interval	No.	Description	Service action	Oil symbol	Capacity / (U.S.gal)	Service points No.
10 Hours or daily	1	Hydraulic oil level	Check, Add	HO	210 (55.5)	1
	2	Engine oil level	Check, Add	EO	30 (7.9)	1
	4	Radiator coolant	Check, Add	C	55 (14.5)	1
	5	Prefilter (water, element)	Check, Clean	-	-	1
	6	Fan belt tension and damage	Check, Adjust	-	-	1
	9	Fuel tank	Check, Refill	DF	600 (158.5)	1
50 Hours or weekly	8	Bucket linkage pin	Check, Add	PGL	-	6
	9	Fuel tank (water, sediment)	Check, Clean	-	-	1
	11	Swing reduction gear case	Check, Add	GO	8.0 (2.1)	1
	14	Track tension	Check, Adjust	PGL	-	2
250 Hours	7	Attachment pins & bushing	Check, Add	PGL	-	11
	10	Swing bearing grease	Check, Add	PGL	-	2
	15	Battery (voltage)	Check	-	-	1
	18	Air breather element	Replace	-	-	1
	21	Aircon and heater fresh air filter	Check, Clean	-	-	1
500 Hours	2	Engine oil	Change	EO	30 (7.9)	1
	3	Engine oil filter	Replace	-	-	1
	5	Prefilter	Replace	-	-	1
	23	Fuel filter element	Replace	-	-	1
	24	Radiator, charge air cooler	Check, Clean	-	-	3
	25	Oil cooler	Check, Clean	-	-	1
	27	Water filter(corrosion resister)	Replace	-	-	1
	27	Coolant test (DCA4 concentration)	Test, Add	DCA4	-	1
1000 Hours	6	Fan belt tensioner	Check, Replace	-	-	1
	11	Swing reduction gear case	Change	GO	8.0 (2.1)	1
	12	Swing reduction gear grease	Change	PGL	1.6 (0.42)	1
	13	Swing gear and pinion grease	Change	PGL	11.4 kg (25.1 lb)	1
	16	Hydraulic oil return filter	Replace	-	-	2
	17	Drain filter cartridge	Replace	-	-	1
	20	Pilot line filter element	Replace	-	-	1
	22	Air cleaner element (primary)	Check, Clean	-	-	1
	26	Travel reduction gear case	Change	GO	12.0 (3.2)	2
2000 Hours	1	Hydraulic oil * <sup>1</sup>	Change	HO	210 (55.5)	1
	4	Radiator coolant	Change	C	55 (14.5)	1
	19	Hydraulic oil suction strainer	Check, Clean	-	-	1
	28	Crankcase breather filter	Replace	-	-	1
	-	Hoses, fittings, clamps (fuel, coolant, hydraulic)	Check, Retighten, Replace	-	-	-
4000 Hours	22	Air cleaner element (primary, safety)	Replace	-	-	2
5000 Hours	1	Hydraulic oil * <sup>2</sup>	Change	HO	210 (55.5)	1
	29	DPF (diesel particulate filter)	Clean	-	-	1
As required	21	Aircon & heater fresh filter	Replace	-	-	1
	21	Aircon & heater recirculation filter	Clean, Replace	-	-	1
	22	Air cleaner element (primary)	Clean, Replace	-	-	1
	22	Air cleaner element (safety)	Replace	-	-	1

\*<sup>1</sup> Conventional hydraulic oil

\*<sup>2</sup> Hyundai genuine long life hydraulic oil

※ Oil symbol

Please refer to the recommended lubricants for specification.

DF : Diesel fuel

GO : Gear oil

HO : Hydraulic oil

C : Coolant

PGL : Grease

EO : Engine oil

## 6. SERVICE INSTRUCTION

### 1) CHECK ENGINE OIL LEVEL

Check the oil level with the machine on a flat ground before starting engine.

- (1) Pull out the dipstick and wipe with a clean cloth.
- (2) Check the oil level by inserting the dipstick completely into the hole and pulling out again.
- (3) If oil level is **LOW**, add oil and then check again.
  - ※ If the oil is contaminated or diluted, change the oil regardless of the regular change interval.
  - ※ Check oil level after engine has been stopped for 15 minutes.
  - ▲ Do not operate unless the oil level is in the normal range.

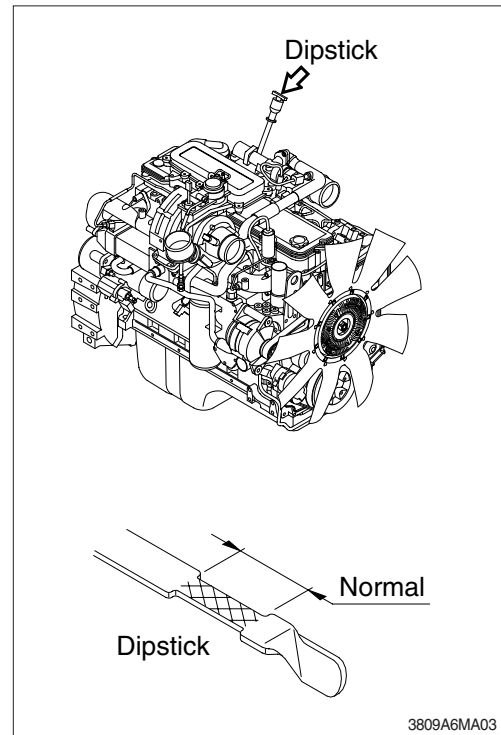

### 2) REPLACEMENT OF ENGINE OIL AND OIL FILTER

- (1) Warm up the engine.
- (2) Remove the plug and allow the oil to drain.
  - ※ A drain pan with a capacity of 40 liters (10.6 U.S. gallons) will be adequate.

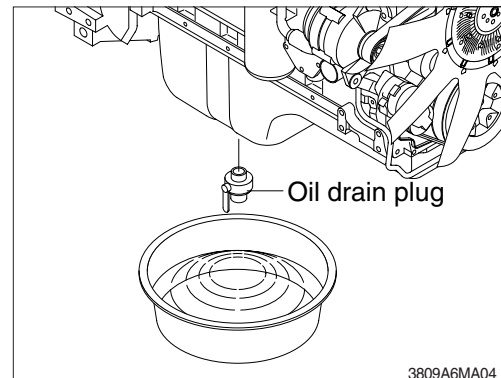

- (3) Clean around the filter head, remove the filter and clean the gasket surface.
  - Wrench size : 75 ~ 85 mm (3.0~3.3 in)
  - ※ The O-ring can stick on the filter head. Make sure it is removed before installing the new filter.

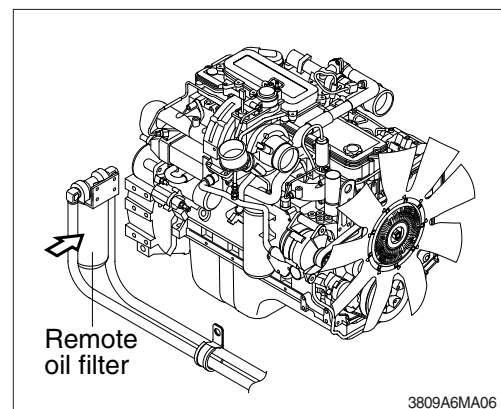

- (4) Apply a light film of lubricating oil to the gasket sealing surface before installing the filters.  
 ※ **Fill the filters with clean lubricating oil.**

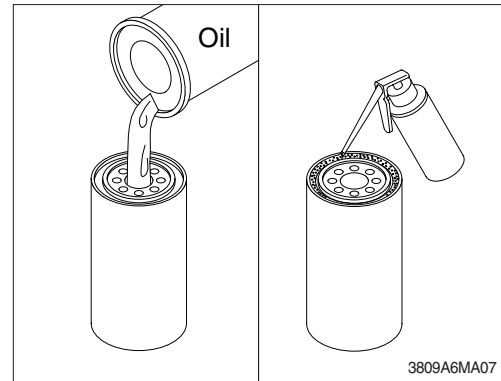

- (5) Install the filter to the filter head.  
 ※ **Mechanical over-tightening may distort the threads or damage the filter element seal.**  
 · Install the filter as specified by the filter manufacturer.

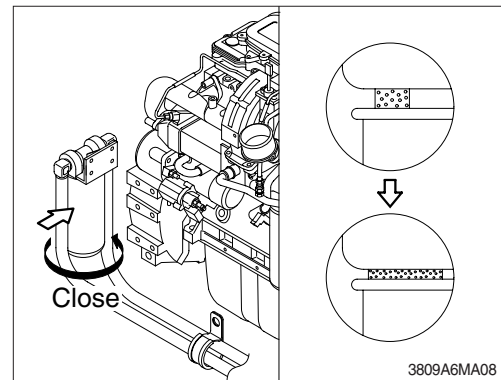

- (6) Fill the engine with clean oil to the proper level.  
 · Quantity : 30 l (7.9 U.S. gallons)

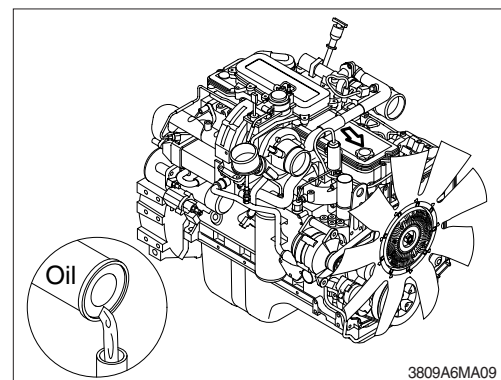

- (7) Operate the engine at low idle and inspect for leaks at the filters and the drain plug.  
 Shut the engine off and check the oil level with the dipstick. Allow 15 minutes for oil to drain down before checking.

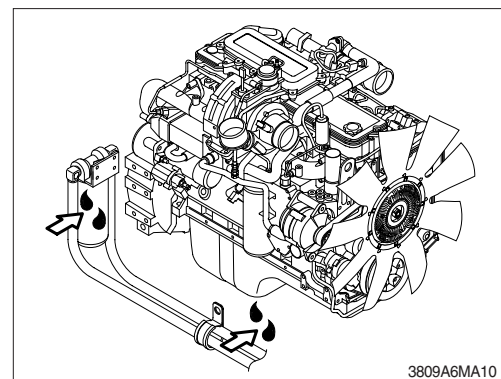



### 3) REPLACEMENT OF WATER FILTER (CORROSION RESISTOR)

(1) Turn the valve to the OFF position.

**▲ Wait until the temperature is below 50°C (122°F) before removing the radiator cap. Remove the coolant system radiator cap and close the shutoff valve before removing the water filter. Failure to do so can result in personal injury from heated coolant spray.**

(2) Remove and discard the water filter.  
Clean the gasket surface.

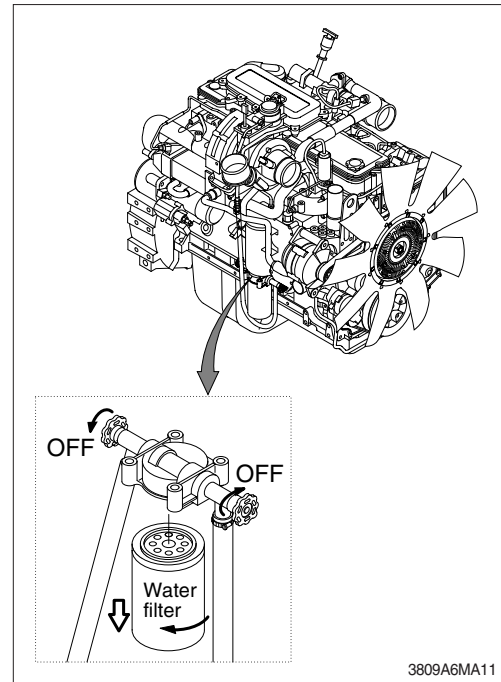

(3) Apply a thin film of lubricating oil to the gasket sealing surface before installing the new water filter.

**▲ Do not allow oil to get into the filter. Oil will damage the DCA.**



(4) Install the water filter on the filter head. Tighten the filter until the gasket contacts the filter head surface.

Tighten the water filter an additional 1/2 to 3/4 of a turn or as specified by the filter manufacturer.

**▲ Mechanical overtightening can distort the threads or damage the filter head.**

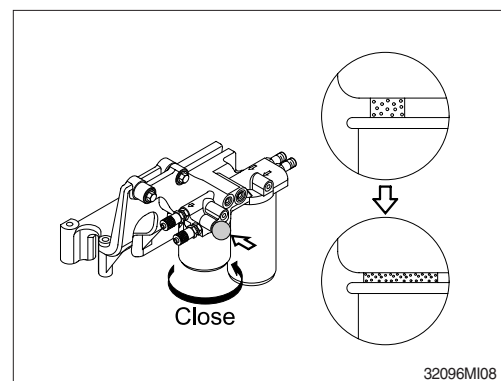

- (5) Install the surge tank cap.
- (6) Operate the engine until it reaches a temperature 80°C (176°F) and check for coolant leaks.

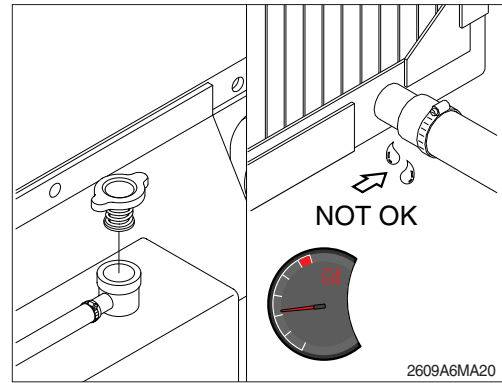

#### 4) CHECK COOLANT

- (1) Check if the level of coolant in reservoir tank is between FULL and LOW.
- (2) Add the mixture of antifreeze and water after removing the cap of the reservoir tank if coolant is not sufficient.
- (3) Be sure to add the coolant by opening the cap of surge tank when coolant level is below LOW.
- (4) Replace gasket of radiator cap when it is damaged.
- ⚠ Hot coolant can spray out if surge tank cap is removed while engine is hot. Remove the cap after the engine has cooled down.

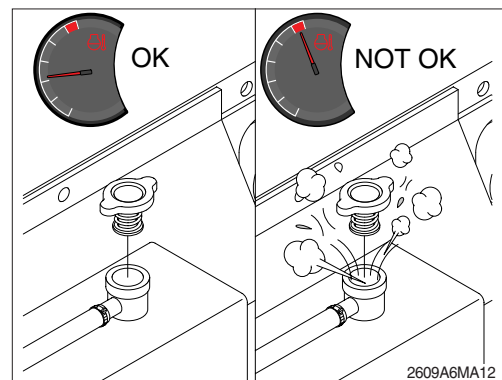
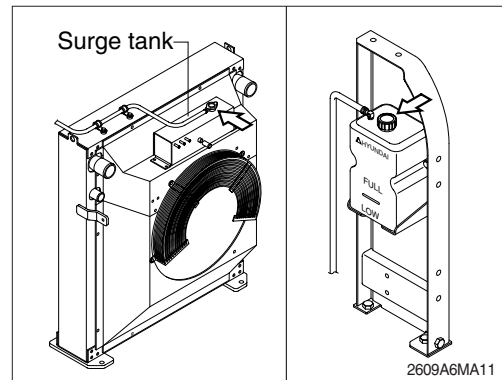

#### 4-1) COOLANT TEST STRIPS INSTRUCTIONS

##### (1) Pre-test instruction

Recommended testing frequency - at every coolant filter change interval.

- ① Collect coolant sample from the radiator drain valve.
  - Do not collect from the coolant recovery or overflow system
  - Coolant must be between 10~54°C when tested
  - Room temperature is best.
- ② For accurate results, test must be completed within 75 seconds.
  - Follow recommended test times. Use a stopwatch.
- ③ Record and track results.



380L6CT01

##### (2) Test instruction

- ① Remove one strip from bottle and replace cap immediately. Do not touch the pads on the end of the strip. Discard kit if nitrite test pads of unused strips have turned brown.
- ② Dip strip for 1 second in coolant sample, remove, and shake strip briskly to remove excess liquid.

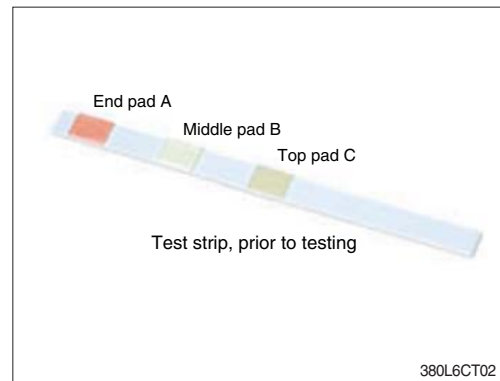

380L6CT02

- ③ 45 seconds after dipping strip, compare results to color chart and record in the following order:

for DCA4:

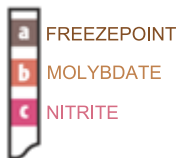

- ④ All three readings must be completed no later than 75 seconds after dipping strip.
- ⑤ If uncertain about the color match, pick the low numbered block. ex.) If nitrite color is not F, use column E.
- ⑥ Determine where the molybdate level intersect the nitrite level on the chart. The amount of SCA units per gallon in the cooling system is given where the molybdate row intersect the nitrite column.

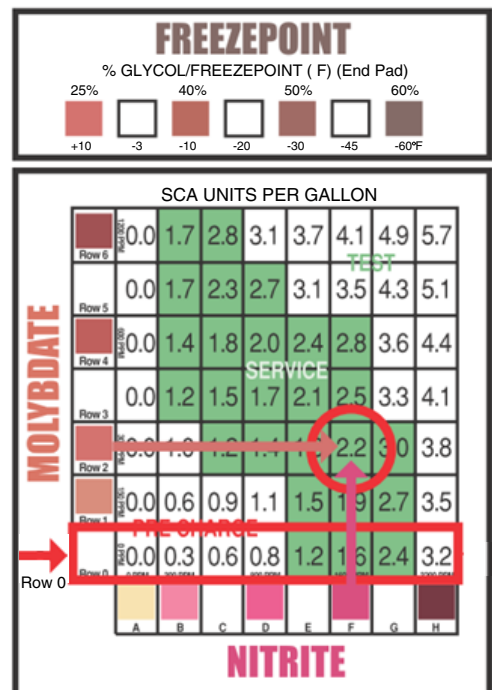

380L6CT03

**(3) Maintenance actions based on results**

**① Above normal**

- ABOVE NORMAL** - Do not replace the coolant filter or add DCA4 liquid until additive concentration falls below 3 units per gallon.
- Test at every subsequent coolant filter change interval.

**② Normal**

- NORMAL** - Continue to replace the coolant filter at your normal interval.

**③ Below normal**

- BELOW NORMAL** - Replace the coolant filter and add 1 pint of additive per each 4 gallons of coolant.
- Replace the coolant filter and add 40 cc of additive per each 1 liter of coolant.

※ If you need part number of Test kit or DCA4, please see Parts Manual.

0.0	1.7	2.8	3.1	3.7	4.1	4.9	5.7
0.0	1.7	2.3	2.7	3.1	3.5	4.3	5.1
0.0	1.4	1.8	2.0	2.4	2.8	3.6	4.4
0.0	1.2	1.5	1.7	2.1	2.5	3.3	4.1
0.0	1.0	1.2	1.4	1.8	2.2	3.0	3.8
0.0	0.6	0.9	1.1	1.5	1.9	2.7	3.5
0.0	0.3	0.6	0.8	1.2	1.6	2.4	3.2
0 PPM	100 PPM	200 PPM	300 PPM	400 PPM	500 PPM	600 PPM	700 PPM

380L6CT04

## 5) FLUSHING AND REFILLING OF RADIATOR

### (1) Change coolant

- ▲ Avoid prolonged and repeated skin contact with used antifreeze. Such prolonged repeated contact can cause skin disorders or other bodily injury.

Avoid excessive contact-wash thoroughly after contact.

Keep out of reach of children.

- ※ Protect the environment : Handling and disposal of used antifreeze can be subject to federal, state, and local law regulation.

Use authorized waste disposal facilities, including civic amenity sites and garages providing authorized facilities for the receipt of used antifreeze.

If in doubt, contact your local authorities for guidance as to proper handling of used antifreeze.

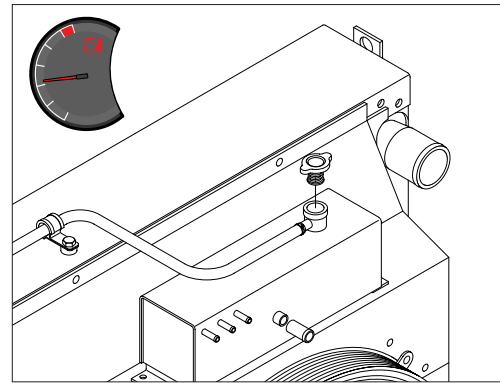

- ▲ Wait until the temperature is below 50 °C (122 °F) before removing the coolant system pressure cap.

Failure to do so can cause personal injury from heated coolant spray.

Drain the cooling system by opening the drain valve on the radiator and removing the plug in the bottom of the water inlet. A drain pan with a capacity of 45 liters (12 U.S. gallons) will be adequate in most applications.

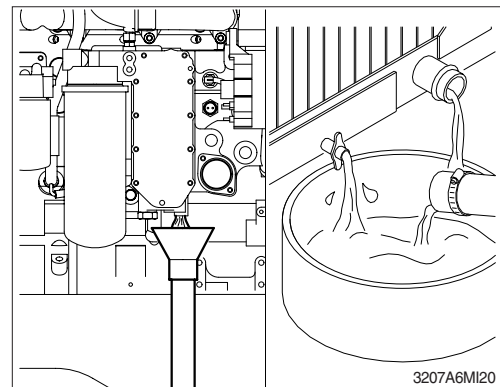

### (2) Flushing of cooling system

- ① Fill the system with a mixture of sodium carbonate and water (or a commercially available equivalent).
- ※ Use 0.5 kg (1.0 pound) of sodium carbonate for every 23 liters (6.0 U.S. gallons) of water.
  - ※ Do not install the surge tank cap. The engine is to be operated without the cap for this process.

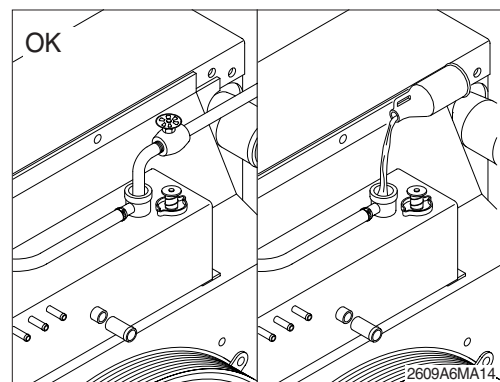

- ② Operate the engine for 5 minutes with the coolant temperature above 80 °C (176 °F) .  
Shut the engine off, and drain the cooling system.

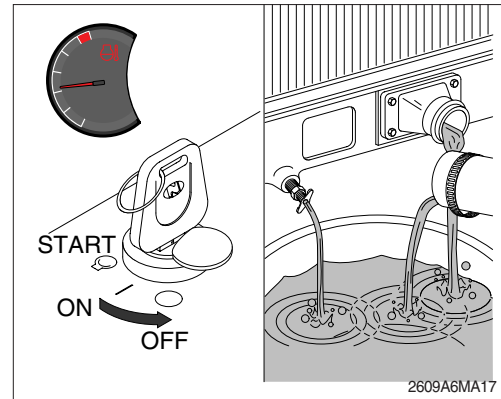

- ③ Fill the cooling system with clean water.  
※ **Be sure to vent the engine and aftercooler for complete filling.**  
※ **Do not install the surge tank cap or the new coolant filter.**

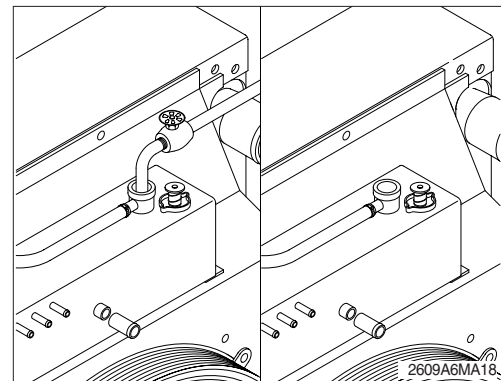

- ④ Operate the engine for 5 minutes with the coolant temperature above 80 °C (176 °F) .  
Shut the engine off, and drain the cooling system.  
※ **If the water being drained is still dirty, the system must be flushed again until the water is clean.**

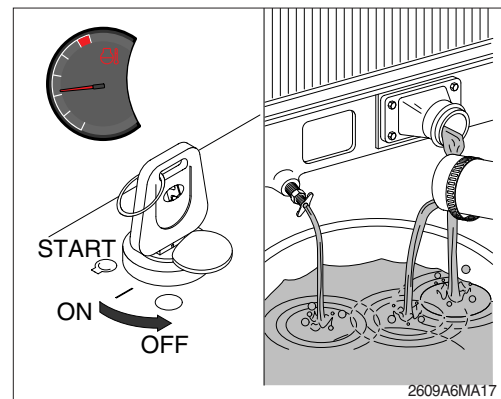

### (3) Cooling system filling

- ① Use a mixture of 50 percent soft water and 50 percent ethylene glycol antifreeze to fill the cooling system. Refer to the page 6-10.  
Coolant capacity (engine only) : 10.4 ℓ (2.7 U.S. gallons)
  - ※ **Never use water alone for coolant.**  
**This can result in damage from corrosion.**
  - ※ **Do not use hard water such as river water or well water.**

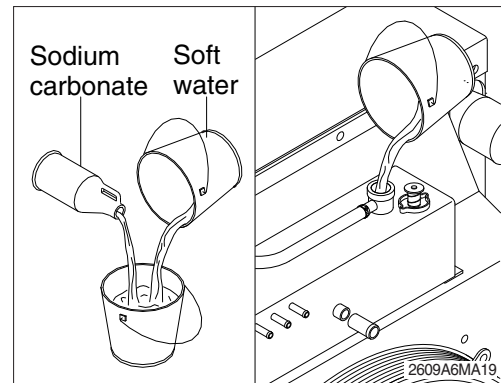

- ② Install the pressure cap. Operate the engine until it reaches a temperature 80°C (176°F), and check for coolant leaks.  
Check the coolant level again to make sure the system is full of coolant.

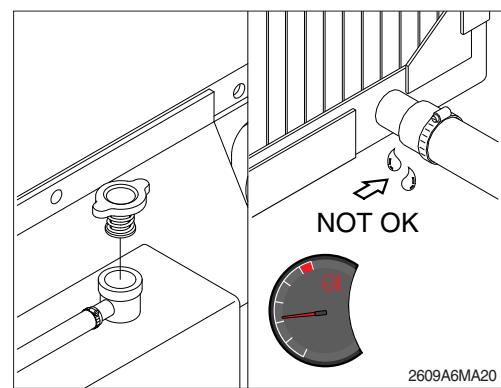

## 6) CLEAN RADIATOR AND OIL COOLER

Check, and if necessary, clean and dry outside of radiator and oil cooler. After working in a dusty place, clean radiator more frequently.

- (1) Visually inspect the radiator for clogged radiator fins.
- (2) Use 550 kPa (80 psi) air pressure to blow the dirt and debris from the fins.  
Blow the air in the opposite direction of the fan air flow.
- (3) Visually inspect the radiator for bent or broken fins.  
※ If the radiator must be replaced due to bent or broken fins which can cause the engine to overheat, refer to the manufacturer's replacement procedures.
- (4) Visually inspect the radiator for core leaks.

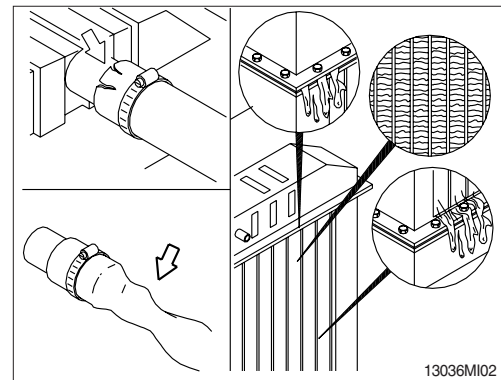
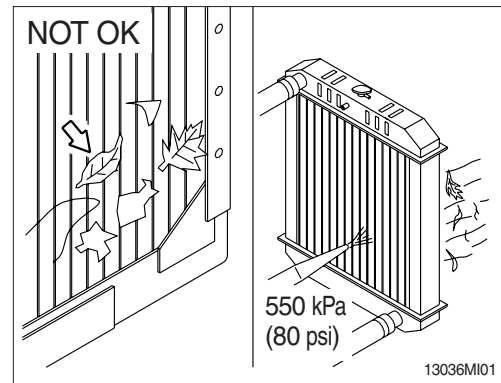

## 7) CHECK CHARGE AIR COOLER

Inspect the charge air cooler for dirt and debris blocking the fins. Check for cracks, holes, or other damage. If damage is found, please contact Hyundai distributor.

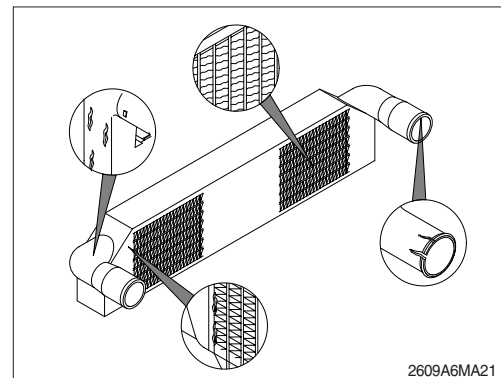



## 8) FAN BELT

- (1) A deflection method can be used to check belt tension by applying 36.3~54.4 kgf (80~120 lbf) force between the pulleys on V-belts. If the deflection is more than one belt thickness per foot of pulley center distance, the belt tension must be adjusted.

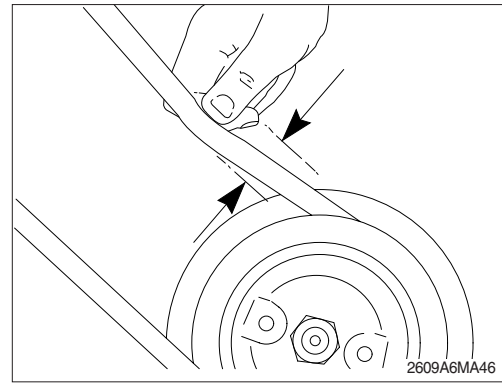

- (2) Inspect the fan belt for damage.

- ① Transverse (across the belt) cracks are acceptable.
- ② Longitudinal (direction of belt ribs) cracks that intersect with transverse cracks are not acceptable.

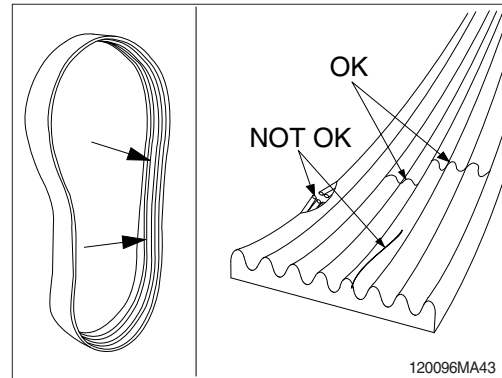

- ③ Inspect the belt

- Embedded debris
- Uneven/excessive rib wear
- Exposed belt cords
- Glazing (high heat)

- ※ If any of the above conditions are present, the belt is unacceptable for reuse and must be replaced.

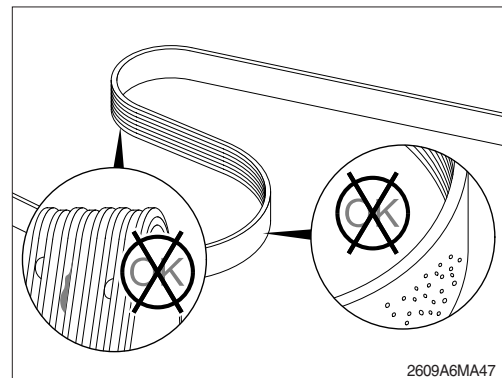

## 9) INSPECTION OF COOLING FAN

- ▲ Personal injury can result from a fan blade failure. Never pull or pry on the fan. This can damage the fan blade and cause fan failure.

- ※ Rotate the crankshaft by using the engine barring gear.

- ※ A visual inspection of the cooling fan is required daily.

Check for cracks, loose rivets, and bent or loose blades.

Check the fan to make sure it is securely mounted. Tighten the capscrews if necessary. Replace any fan that is damaged.

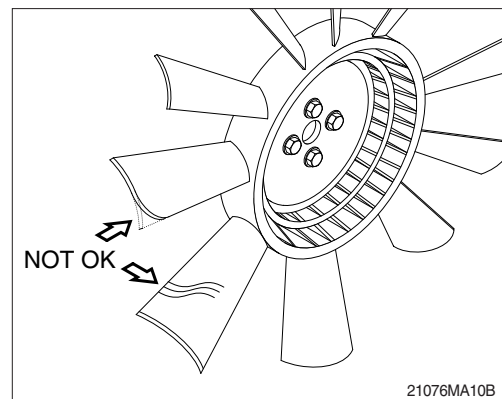

## 10) FAN BELT TENSIONER

- (1) With the engine stopped, check the tensioner arm, pulley, and stops for cracks. If any cracks are found, the tensioner must be replaced.

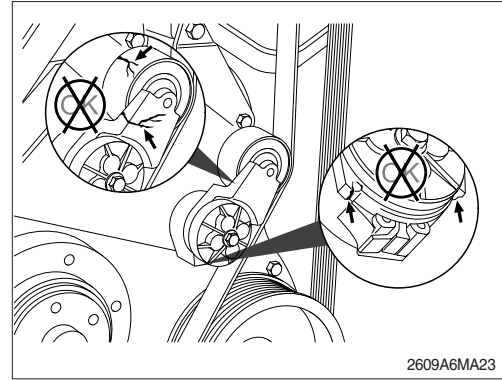

- (2) With the belt installed, verify that neither tensioner arm stop is in contact with the spring case stop.

After replacing the belt, if the tensioner arm stops are still in contact with the spring case stop, replace the tensioner.

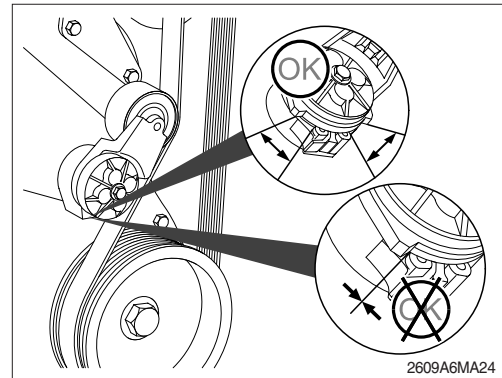

- (3) With the belt removed, verify that the tensioner arm stop is in contact with the spring case stop. If these two are not touching, the tensioner must be replaced.

- ※ After replacing the belt, if the tensioner arm stop is still in contact with the spring case stop, the tensioner must be replaced.

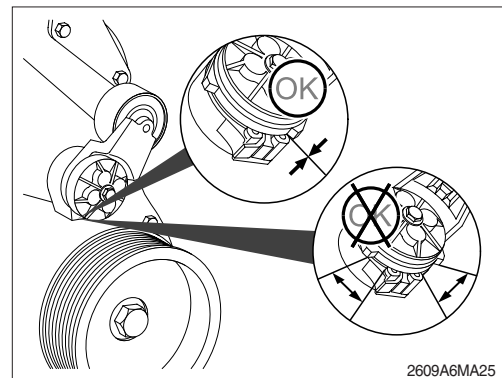

- (4) Check the location of the drive belt on the belt tensioner pulley. The belt should be centered on, or close to the middle of, the pulley. Misaligned belts, either too far forward or backward, can cause belt wear, belt roll-offs, or increase uneven tensioner bushing wear.

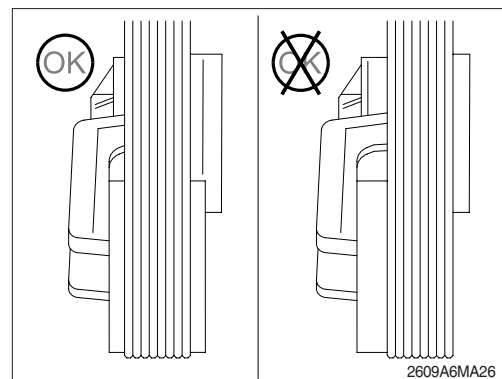

- (5) A worn tensioner that has play in it or a belt that “walks” off its pulley possibly indicates pulley misalignment.
- ※ **Maximum pulley mislignment is three degrees. This measurement can be taken with a straightedge and an inclinometer.**
- (6) Install the belt.

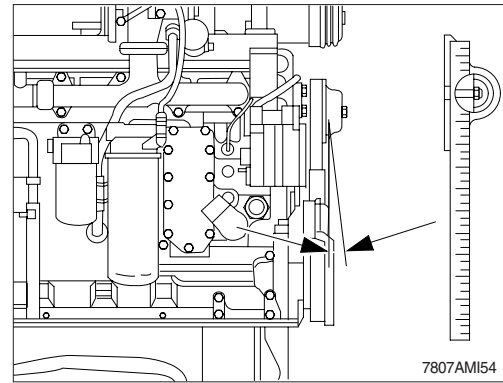

## 11) CLEANING OF AIR CLEANER

### (1) Primary element

- ① Open the cover and remove the element.
- ② Wipe all contaminant and debris from inside the housing body.
- ③ Do not clean the filter element by striking or hitting the filter against any object to shake the debris from the filter element.
- ④ Clean the filter element with compressed air.
  - a. Remove dust from filter element by directing the compressed air into the opening of the air filter element.
  - b. Use  $3 \text{ kg/cm}^2$  (40 psi) maximum air pressure and hold the compressed air nozzle at least 2.5 cm (1") away from the pleats while cleaning. Make sure to keep the clean side of air filter free of debris.
- ⑤ Visually inspect for damage to the filter elements and components. Use a light source to help identify any defects in the media. If any defects are observed discard the filter element and replace with a new primary filter element.
  - a. Before any type of cleaning, a visual inspection of the filter is needed. If there is any damage to the filter body, gaskets or endplates, do not clean or reuse; the filter should be discarded. Always clean filters in a clean environment, observe strict inspection procedures and repackage filters immediately after the cleaning process with appropriate materials.
  - b. Use observe proper safety precautions and dispose of waste materials in an environmentally compliant manner.
- ⑥ Re-install filter element into the air housing.
- ⑦ Replace the primary element at the fourth cleaning.

### (2) Safety element

The safety filter element should never be cleaned since the safety filter is the last barrier to contaminant before it reaches engine.

The useful life of the safety filter is equivalent to that of the primary air filter only if the primary filter element is being regularly cleaned. If the primary filter element is not cleaned, the safety filter should be changed at every third primary air filter change or after one year of continuous service, whichever occurs first.

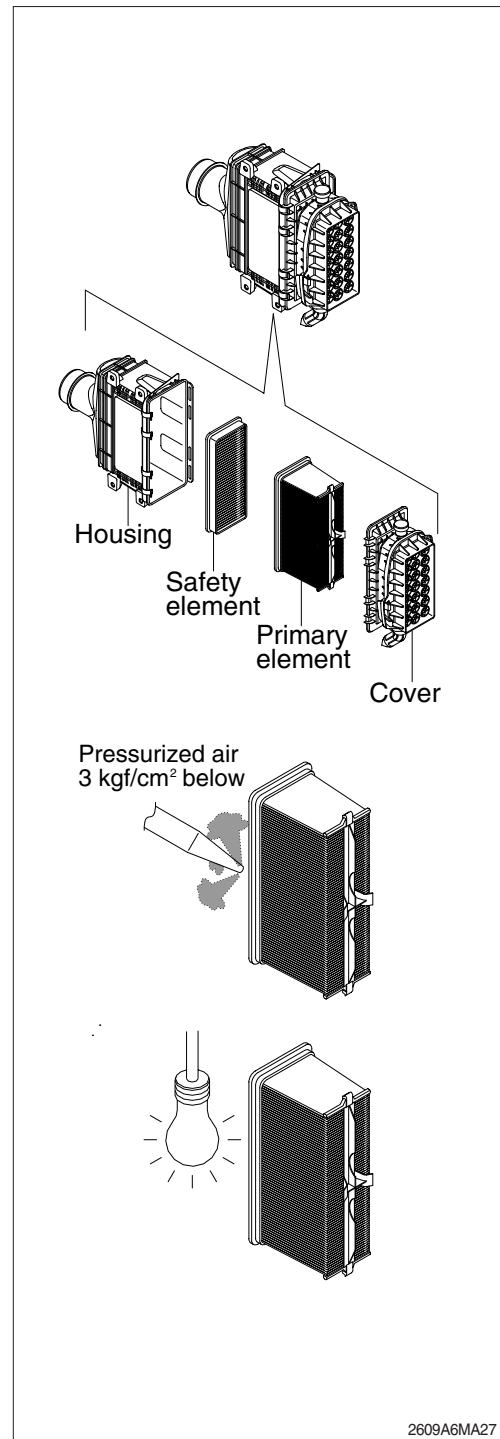

2609A6MA27

## 12) FUEL TANK

- (1) Fill fuel fully when system the operation to minimize water condensation, and check it with fuel gauge before starting the machine.
- (2) Drain the water and sediment in the fuel tank by opening the drain cock.
  - ※ **Be sure to LOCK the cap of fuel tank.**
  - ※ **Remove the strainer of the fuel tank and clean it if contaminated.**
- ▲ **Stop the engine when refueling.**  
All lights and flames shall be kept at a safe distance while refueling.

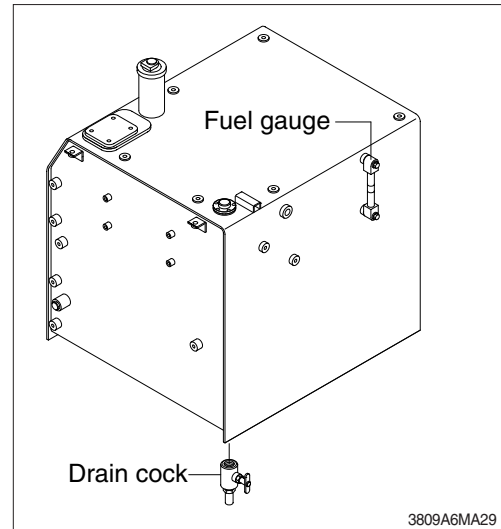

## 13) REPLACEMENT OF FUEL FILTER

- (1) Clean around the filter head, remove the filter and clean the gasket surface.
- (2) Replace the O-ring.
  - ※ **Make sure O-ring does not stick to filter head.**
  - Remove O-ring with screwdriver if necessary.
- (3) Apply engine oil on the gasket of new filter when mounting, and tighten 3/4 to 1 turn more after the gasket touches the filter head.
  - ※ **Mechanical overtightening can distort the threads or damage the filter element seal.**
- (4) Relieve the air after mounting.
  - ※ **Do not pre-fill an on-engine fuel filter with fuel.** The system must be primed after the fuel filter is installed. Pre filling the fuel filter can result in debris entering the fuel system and damaging fuel system components.
  - ※ **Check for fuel leakage after the engine starts.** If air is in the fuel system, the engine will not start. Start engine after bleeding the air according to the method of bleeding air.

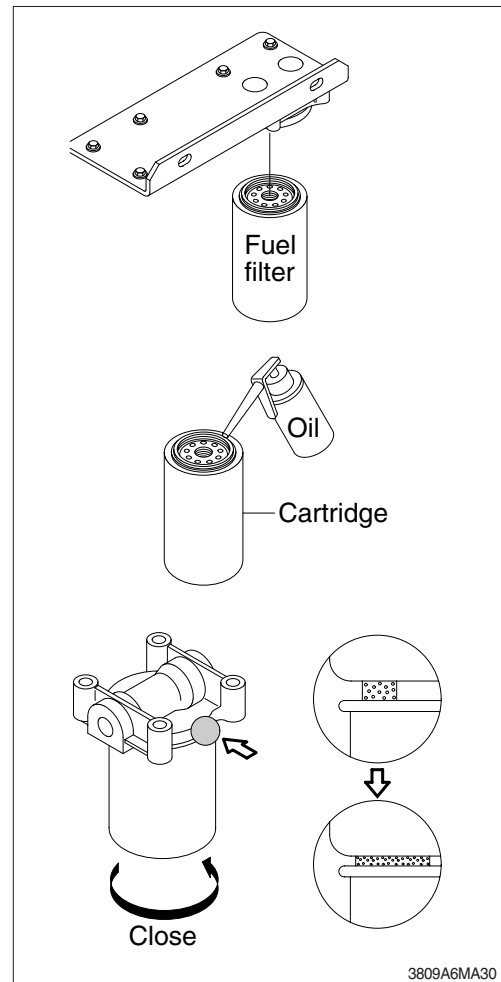

#### 14) BLEEDING THE FUEL SYSTEM

- (1) Loosen fuel supply line plug at the outlet of prefilter.
- (2) Do hand-priming the lift pump repeatedly until air bubbles comes out from fuel supply line completely.
- (3) Tighten fuel supply line to its origin position.

**▲ The fuel pump, high-pressure fuel lines and fuel rail contain very high-pressure fuel. Never loosen any fittings while the engine is running. Personal injury and property damage can result. Wait at least 10 minutes after shutting down the engine before loosening any fittings in the high-pressure fuel system to allow pressure to do decrease to a lower level.**

#### 15) LEAKAGE OF FUEL

**▲ Be careful and clean the fuel hose, injection pump, fuel filter and other connections as the leakage from these part can cause fire.**

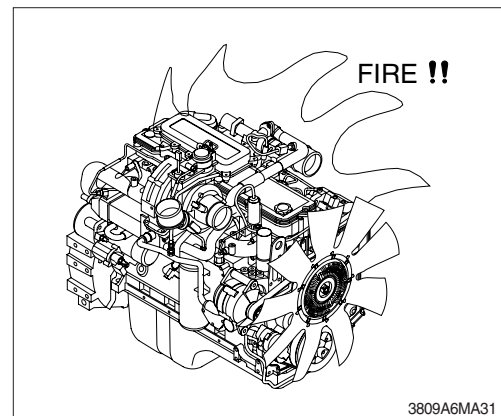
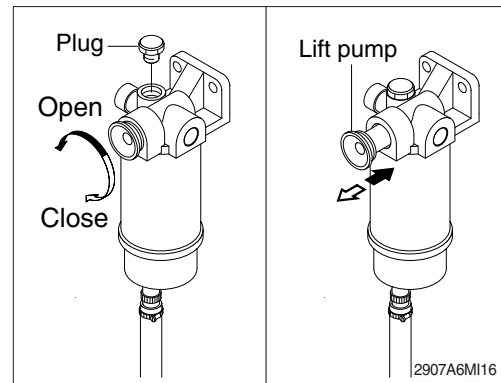

## 16) PREFILTER

※ Inspect or drain the collection bowl of water daily and replace the element every 500hours.

### (1) Drain water

- ① Open bowl drain valve to evacuate water.
- ② Close drain valve.

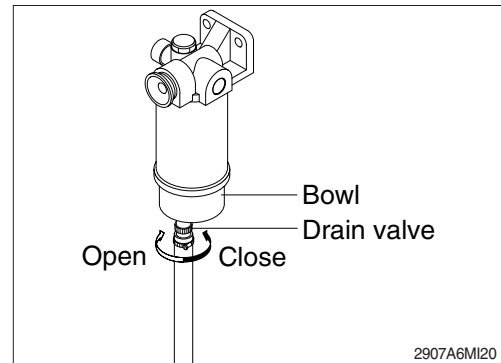

### (2) Replace element

- ① Drain the unit of fuel. Follow "Drain water" instructions above.
- ② Remove element, fuel warmer and bowl from filter head.
- ※ **The bowl is reusable, do not damage or discard.**
- ③ Separate element from bowl. Clean bowl and seal gland.
- ④ Lubricate new bowl seal with clean fuel or motor oil and place in bowl gland.
- ⑤ Attach bowl to new element firmly by hand.
- ⑥ Lubricate new element seal and place in element top gland.
- ⑦ Attach the element, fuel warmer and bowl to the head.

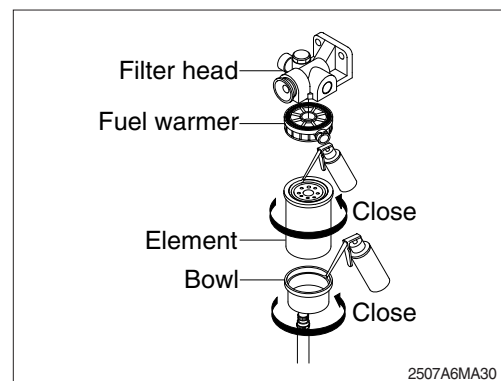
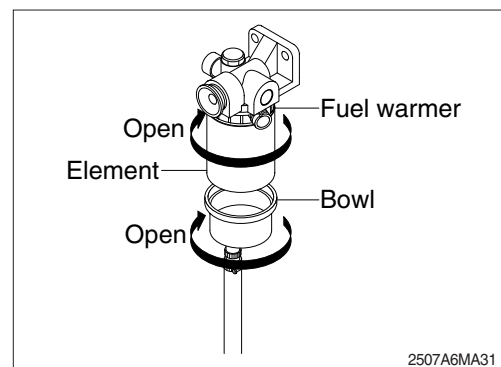

## 17) AFTERTREATMENT DEVICE

(1) The aftertreatment system is used to reduce particulate emissions, and is composed of six main components :

- ① Aftertreatment inlet and aftertreatment diesel oxidation catalyst.
- ② Aftertreatment diesel particulate filter differential pressure sensor.
- ③ Aftertreatment diesel particulate filter.
- ④ Aftertreatment outlet.
- ⑤ Aftertreatment exhaust gas temperature sensors.
- ⑥ Aftertreatment diesel particulate filter temperature sensor interface module.

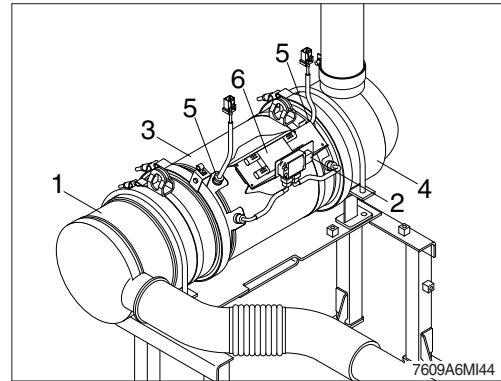

### (2) DPF (diesel particulate filter) cleaning

The diesel particulate filter can not be cleaned for maintenance purpose using conventional tools. The diesel particulate filter needs to be cleaned and checked using an approved cleaning machine at a authorized service center.

- ※ The diesel particulate filter shall be cleaned every 5000 hours.
- ※ Please contact your Hyundai service center or local dealer.

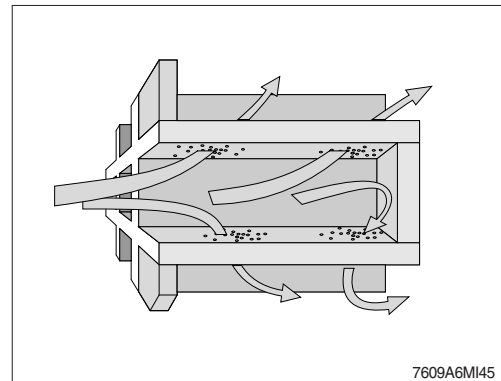

## 18) CRANKCASE BREATHER FILTER

※ Do not use pneumatic tools to remove the breather cover capscrews. Damage to the rocker cover can result.

- (1) Remove the oil fill cap.
- (2) Remove the crankcase breather filter cover capscrews.
- (3) Remove the filter cover.

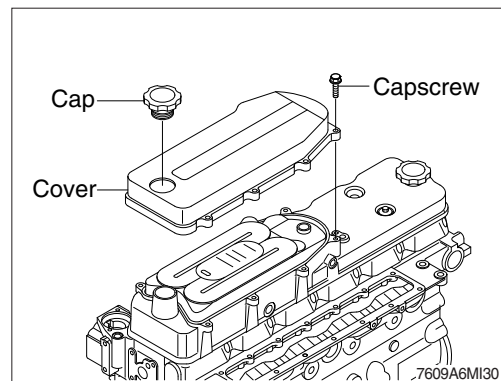

- (4) Remove the crankcase breather filter from the rocker lever cover.

- ※ Do not disturb the crankcase breather filter gasket located on the rocker lever cover.
- ※ Exposure to oil can cause the gasket to swell, which can make it difficult to install the gasket back into groove. If the gasket comes out of the groove, do not attempt to install the gasket. Replace it with a new gasket.

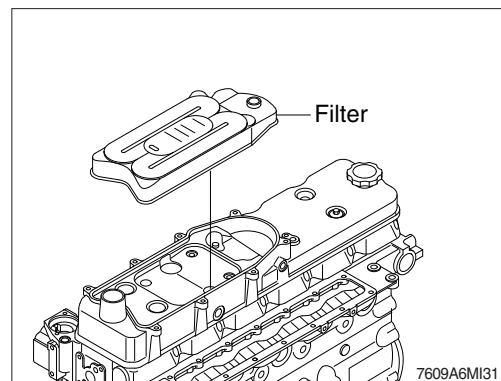



- (5) If the gasket is damaged, remove the gasket by grasping the tab on the gasket and pulling up.
- (6) Clean the crankcase breather filter mounting surface and O-ring sealing surfaces on the rocker lever cover.
- (7) Clean the crankcase breather filter cover with warm soapy water.  
Inspect the cover for cracks.  
Replace the cover if damage is found.

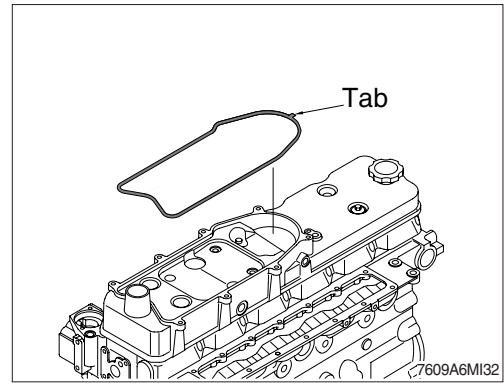

- (8) If the gasket was removed, install the gasket into the rocker lever cover groove starting with the tab end first. Then install the corners opposite the gasket tab end. Finish by pushing in the sides (see illustration).

Gently push the gasket down into the groove. Do not use a finger to trace the gasket around into the groove during installation, as this will stretch the gasket, making it difficult to fully seat into the groove.

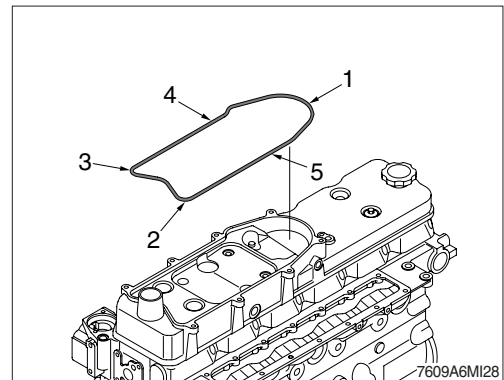

- ※ **Do not cut the gasket to make it fit into the groove, as this will result in an oil leak. The gasket must be fully seated around the entire perimeter of the rocker lever cover groove.**

- (9) Apply clean engine oil to the O-rings on the crankcase breather filter.  
Install the filter onto the rocker lever cover.

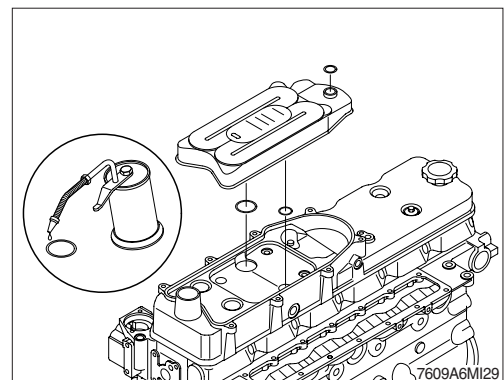

- (10) Install the crankcase breather filter cover.  
Install the filter cover capscrews.  
Tighten the capscrews, starting with the innermost capscrews and working outward in a circular manner.  
· 0.71 kgf · m (5.16 lbf · ft)  
Install the oil fill cap.

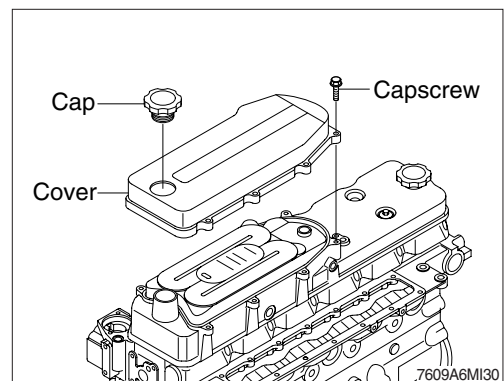

## 19) HYDRAULIC OIL CHECK

- (1) Position the machine as shown in the illustration on the right. Then stop engine.
- (2) Check the oil level at the level gauge of hydraulic oil tank.
- (3) The oil level is normal if the oil is between the red lines. The oil level depends on the temperature of the hydraulic oil. Refer to the height (A) in the below table to check the level gauge.

Temperature		Height A	
°C	°F	mm	inch
0	32	15	0.6
10	50	25	1.0
20	68	30	1.2
30	86	35	1.4
40	104	40	1.6

※ Refer to page 3-17 for checking the temperature of the hydraulic oil.

※ Add the hydraulic oil, if necessary.

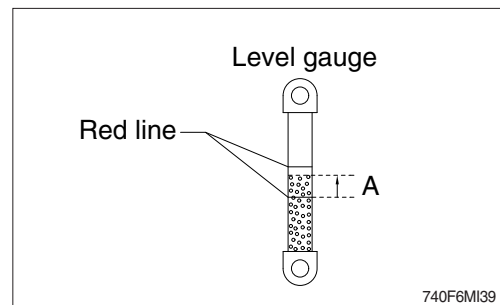
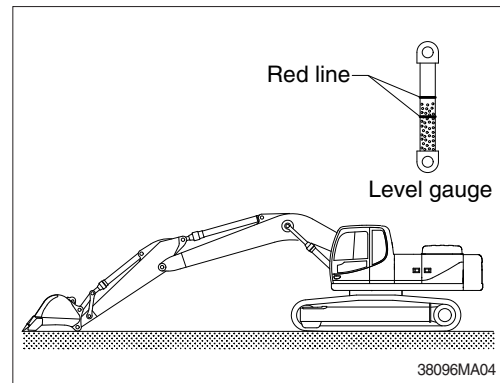

## 20) FILLING HYDRAULIC OIL

- (1) Stop the engine to the position of level check.
- (2) Loosen the cap and relieve the pressure in the tank by pushing the top of the air breather.
- (3) Remove the breather on the top of oil tank and fill the oil to the specified level.
  - Tightening torque :  $1.44 \pm 0.3$  kgf · m  
( $10.4 \pm 2.1$  lbf · ft)
- (4) Start engine after filling and operate the work equipment several times.
- (5) Check the oil level at the level check position after engine stops.

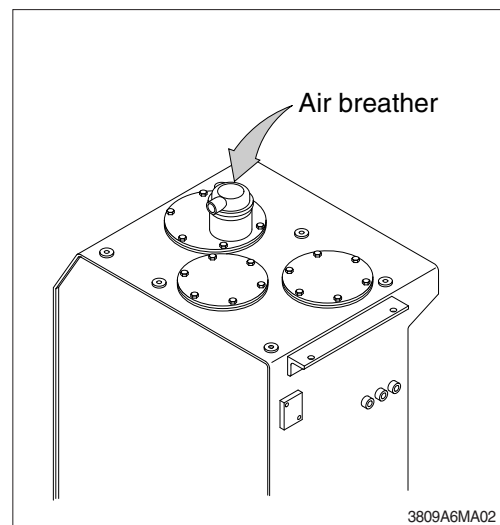

## 21) CHANGE HYDRAULIC OIL

- (1) Lower the bucket on the ground pulling the arm and bucket cylinder to the maximum.
- (2) Loosen the cap and relieve the pressure in the tank by pushing the top of the air breather.
- (3) Remove the cover.
  - Tightening torque :  $6.9 \pm 1.4 \text{ kgf} \cdot \text{m}$   
( $50 \pm 10 \text{ lbf} \cdot \text{ft}$ )
- (4) Prepare a suitable container.
- (5) To drain the oil loosen the drain plug at the bottom of the oil tank.
- (6) Fill proper amount of recommended oil.
- (7) Put the breather in the right position.
- (8) Bleed air hydraulic pump loosen the air breather at top of hydraulic pump assembly.
- (9) Start engine and run continually. Release the air by full stroke of each control lever.

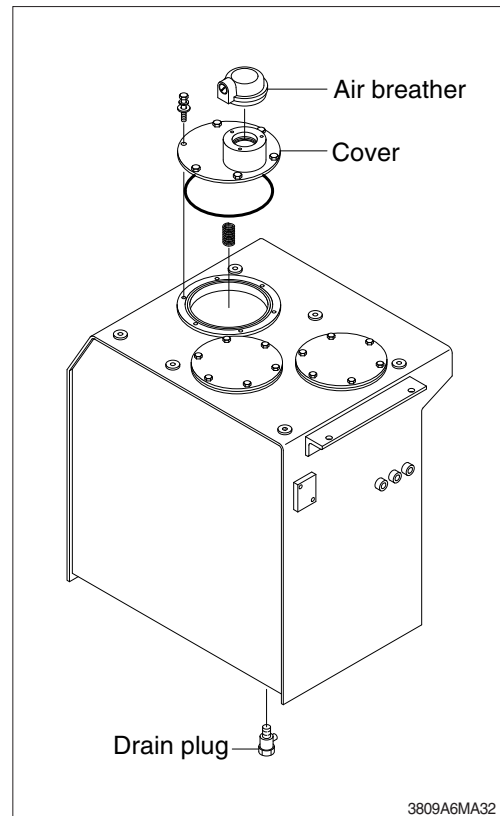

## 22) CLEAN SUCTION STRAINER

Clean suction strainer as follows paying attention to the cause to be kept during oil filling.

- (1) Remove the cover on the top of the oil tank.
    - Tightening torque :  $6.9 \pm 1.4$  kgf · m  
( $50 \pm 10$  lbf · ft)
  - (2) Pull out the strainer in the tank.
  - (3) Wash the foreign material on the suction strainer with gasoline or cleaning oil.
  - (4) Replace the suction strainer if it is damaged.
  - (5) Assemble with reverse order of disassembly.  
Be sure to install a new O-ring and reinsert in the oil tank.
- ※ Loosen the bolt slowly at the cover can be spring out by the spring when removing it.

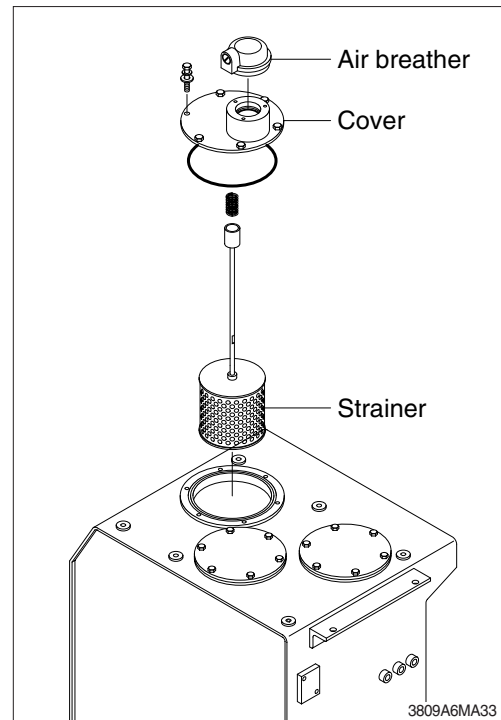

## 23) REPLACEMENT OF RETURN FILTER

Replace as follows paying attention to the cause to be kept during the replacement.

- (1) Remove the cover.
  - Tightening torque :  $6.9 \pm 1.4$  kgf · m  
( $50 \pm 10$  lbf · ft)
- (2) Remove the spring, by-pass valve, and return filter in the tank.
- (3) Replace the element with new one.

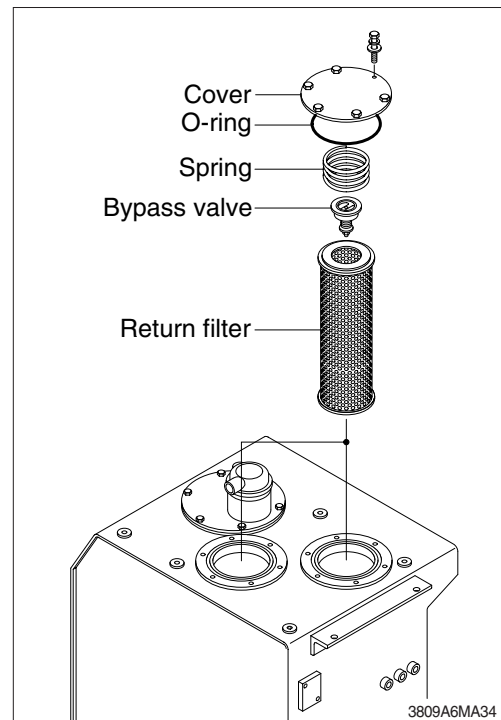

## 24) REPLACEMENT OF ELEMENT IN HYDRAULIC TANK BREATHER

- (1) Loosen the cap and relieve the pressure in the tank by pushing the top of the air breather.
- (2) Loosen the lock nut and remove the cover.
- (3) Pull out the filter element.
- (4) Replace the filter element new one.
- (5) Reassemble by reverse order of disassembly.
  - Tightening torque : 0.2~0.3 kgf · m  
(1.4~2.1 lbf · ft)

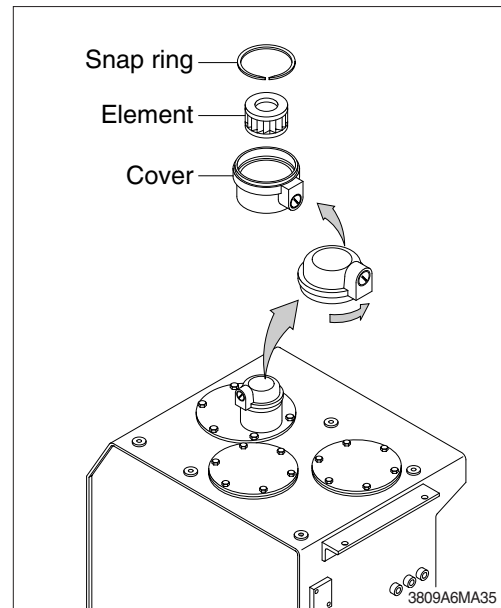

## 25) REPLACE OF DRAIN FILTER CARTRIDGE

Clean the dust around filter and replace with new one after removing the cartridge.

- ※ Tighten about 2/3 turn more after the gasket of cartridge contacts seal side of filter body for mounting.
- ※ Change cartridge after initial 250 hours of operation. Thereafter, change cartridge every 1000 hours.

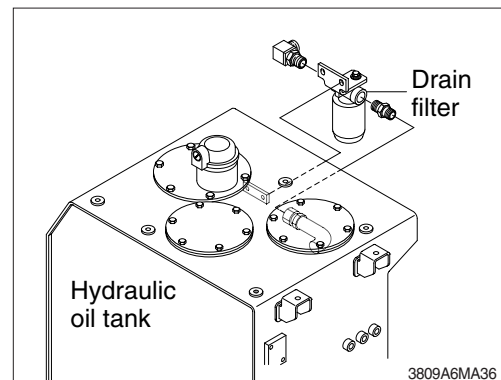

## 26) REPLACE OF PILOT LINE FILTER

- (1) Loosen the nut positioned on the filter body.
  - (2) Pull out the filter element and clean filter housing.
  - (3) Install the new element and tighten using specified torque.
- ※ Change cartridge after initial 250 hours of operation. Thereafter, change cartridge every 1000 hours.

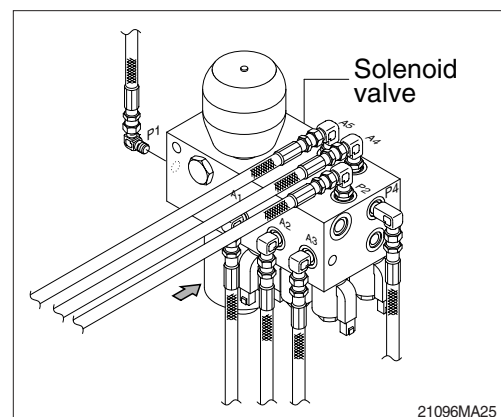

### 27) CHECK THE SWING REDUCTION GEAR OIL

- (1) Pull out the dipstick and clean it.
- (2) Insert it again.
- (3) Pull out one more time to check the oil level and fill the oil if the level is not sufficient.

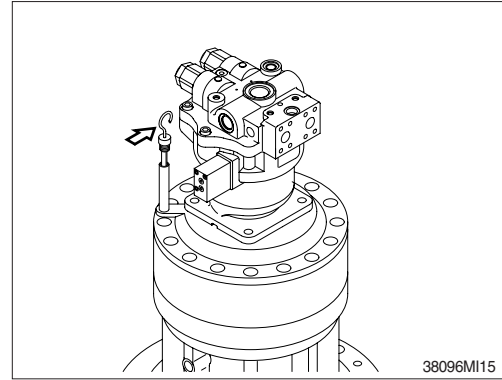

### 28) CHANGE SWING REDUCTION GEAR OIL

- (1) Raise the temperature of oil by swinging the machine before replace the oil and park the machine on the flat ground.
- (2) Prepare a proper container.
- (3) Open the cap and loosen the drain valve.
- (4) Clean around the valve and close the drain valve and cap.  
Fill proper amount of recommended oil.  
· Amount of oil : 8.0 ℓ (2.1 U.S.gal)

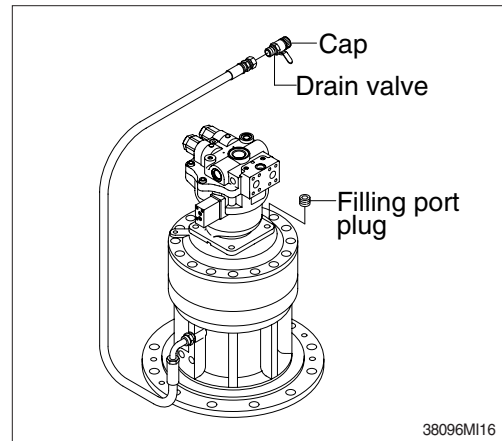

### 29) LUBRICATE BEARING OF OUTPUT SHAFT IN REDUCTION GEAR

- (1) Remove air vent plug.
- (2) Lubricate NLGI No.2 with grease gun until comes out new grease from air vent port.  
· Amount of oil : 1.6 kg (0.42 lb)

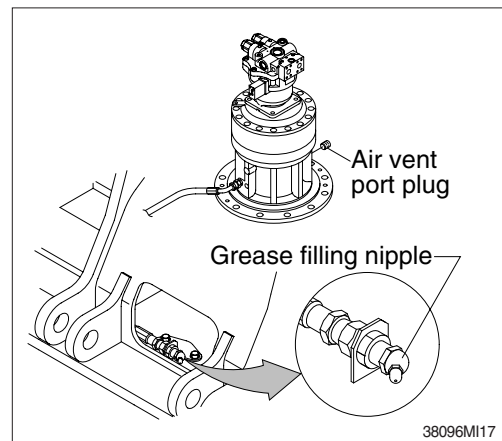

### 30) LUBRICATE SWING BEARING

- (1) Grease at 2 fitting.  
※ Lubricate every 250 hours.

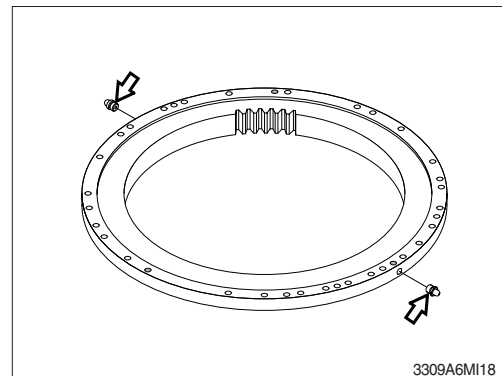

### 31) SWING GEAR AND PINION

#### (1) Drain old grease

- ① Remove under cover of lower frame.
- ② Remove drain cover of lower frame.
- ③ Remove filler cover of upper frame.
- ④ Operate full turn (360°) of swing several times.

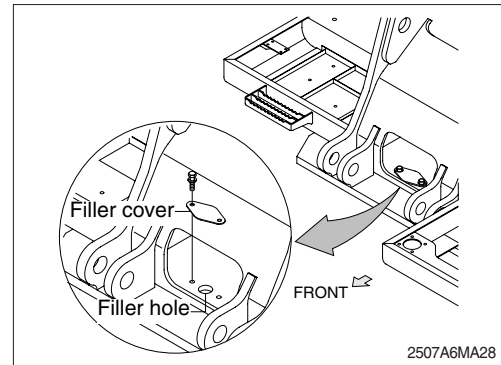

#### (2) Refill new grease

- ① Install drain cover.
- ② Fill with new grease.
- ③ Install filler cover.
  - Capacity : 11.4 kg (25.1 lb)

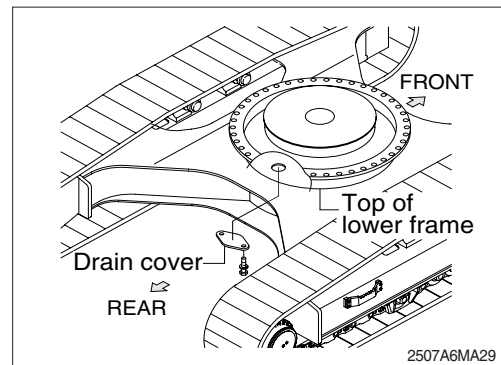

### 32) CHECK THE TRAVEL REDUCTION GEAR OIL

- (1) Operate the machine to the position of drain plug down to the flat ground.
- (2) Loosen the level plug and check the oil level. If the level is at the hole of the plug, it is normal. Fill the oil if it is not sufficient.
  - Amount of oil : 12.0 ℓ (3.2 U.S.gal)

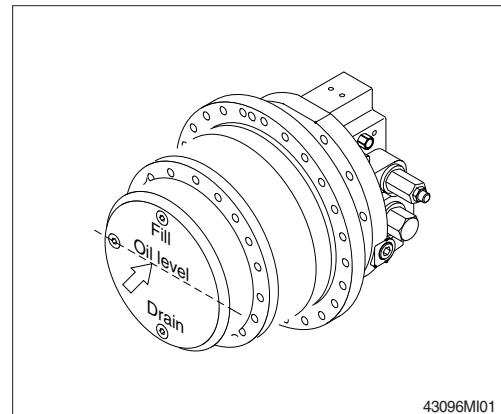

### 33) CHANGE OF THE TRAVEL REDUCTION GEAR OIL

- (1) Raise the temperature of the oil by traveling machine first.
- (2) Stop when the position of the drain plug is down.
- (3) Loosen the level plug and then the drain plug.
- (4) Drain the oil to adequate container.
- (5) Tighten the drain plug and fill specified amount of oil at filling port.
- (6) Tighten the level plug and travel slowly to check if there is any leakage of oil.

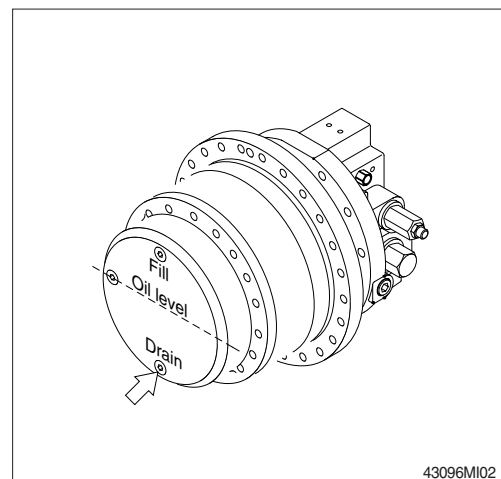

### 34) LUBRICATE RCV LEVER

Remove the bellows and with a grease gun grease the joint part (A) and sliding parts (B).

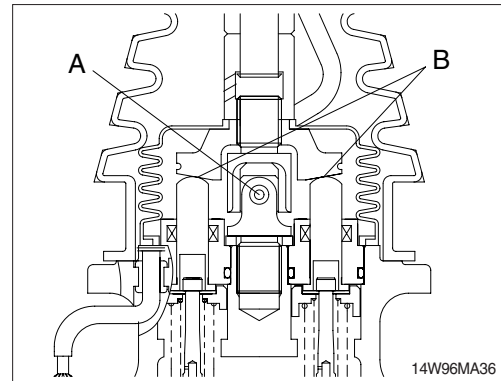

### 35) ADJUSTMENT OF TRACK TENSION

- ※ It is important to adjust the tension of track properly to extend the lifetime of track and traveling device.
- ※ The wear of pins and bushings on the undercarriage will vary with the working conditions and soil properties.  
It is thus necessary to continually inspect the track tension so as to maintain the standard tension on it.

- (1) Raise the chassis with the boom and arm.
- (2) Measure the distance between bottom of track frame on track center and track of shoe.
- ※ Remove mud with rotating the track before measuring.

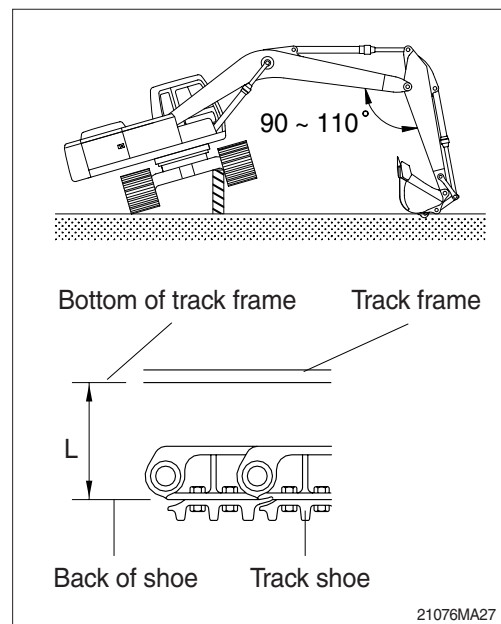

- (3) If the tension is tight, drain the grease in the grease nipple and if the tension is loose, charge the grease.

- ▲ Personal injury or death can result from grease under pressure.
- ▲ When loosening the grease nipple, do not loosen more than one turn as there is a danger of a spring coming out of the nipple because of the high pressure inside.
- ※ When the grease is drained, move the track to the forward and backward slightly.  
If the track tension is loose even after the grease is charged to the maximum, change the pins and bushings as there are worn seriously.

Working condition	Length (L)	
	General	390~420 mm
Swamp	420~460 mm	16.5~18.1"
Sand, Mud, pebbes	About 460 mm	About 18.1"



### 36) REPLACEMENT OF BUCKET

**▲** When knocking the pin in with a hammer, metal particles may fly and cause serious injury, particularly if they get into your eyes. When carrying out this operation, always wear goggles, helmet, gloves, and other protective equipment.

※ When the bucket is removed, place it in a stable condition.

※ When performing joint work, make sure signals to each other and work carefully for safety's sake.

(1) Lower the bucket on the ground as the picture shown in the right.

(2) Lock the safety lever to the LOCK position and stop the engine.

(3) Remove the stopper bolts (1) and nuts (2), then remove pins (3, 4) and remove the bucket.

※ When removing the pins, place the bucket so that it is in light contact with the ground.

※ If the bucket is lowered strongly to the ground, the resistance will be increased and it will be difficult to remove the pins.

※ After remove the pins, make sure that they do not become contaminated with sand or mud and that the seals of bushing on both sides do not become damaged.

(4) Align the arm with holes (A) and the link with holes (B), then coat with grease and install pins(3, 4)

※ When installing the bucket, the O-rings are easily damaged, so fit the O-rings on the boss of the bucket as shown in the picture.

After knocking the pin, move the O-ring down to the regular groove.

(5) Install the stopper bolt (1) and nuts (2) for each pin, then grease the pin.

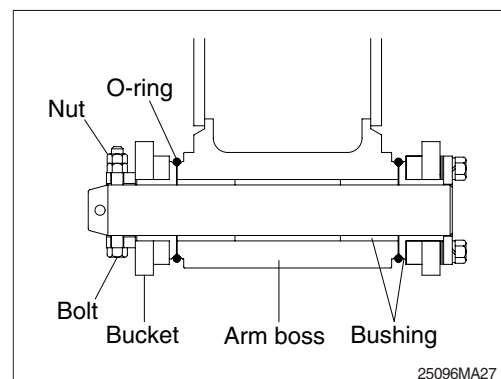
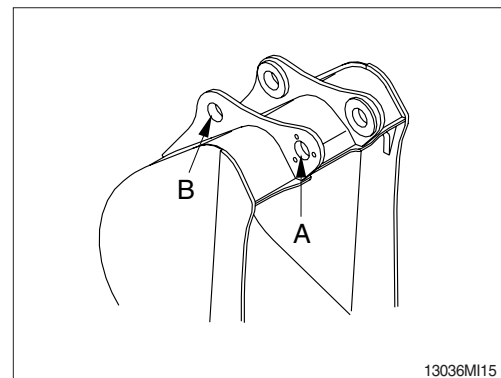
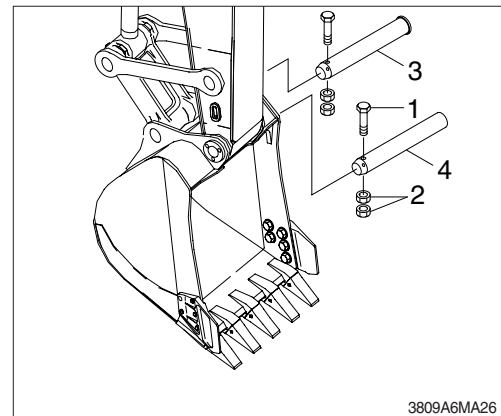
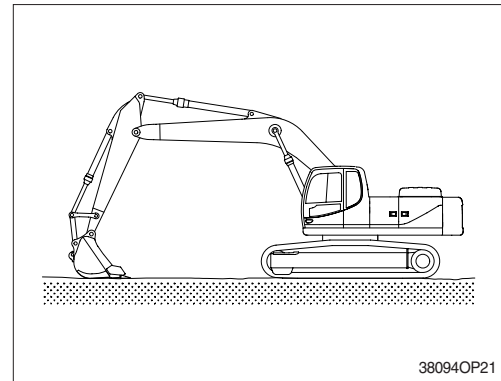

### 37) REPLACEMENT OF BUCKET TOOTH

#### (1) Timing of replacement

- ① Check wearing condition as shown in the illustration and replace tooth tip before adapter starts to wear.
- ② If excessive use, tooth adapter has worn out, replacement may become impossible.

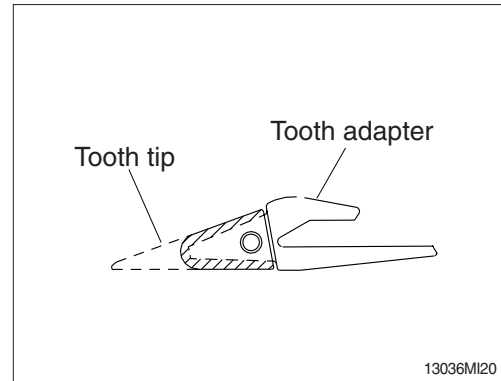

#### (2) Instructions for replacement

- ① Pull out pin by striking pin with punch or hammer, avoiding damage to locking washer.
- ② Remove dust and mud from surface of tooth adapter by using knife.
- ③ Place locking washer in its proper place, and fit tooth tip to adapter.
- ④ Insert pin until locking washer is positioned at tooth pin groove.

- ▲ Personal injury can result from bucket falling.
- ▲ Block the bucket before changing tooth tips or side cutters.

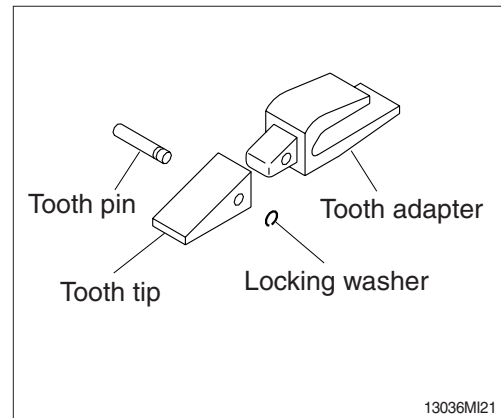

### 38) ADJUSTMENT OF BUCKET CLEARANCE

- (1) Lower the bucket on the ground as the picture shown in the right.
- (2) Swing to the left and keep the arm boss to be contact to the bucket left.
- (3) Lock the safety lever to the LOCK position and stop the engine.
- (4) Measure the clearance (A) between bucket and arm boss. This is the total clearance.

#### (5) Adjusting

- ① Loosen bolt (2), and remove washer (3), plate (1) and shim (4).
- ② Remove the shim equivalent value with measuring value.
- ③ Assemble the parts in the reverse order of removal.
  - Tightening torque :  $29.6 \pm 3.2 \text{ kgf} \cdot \text{m}$   
( $214.0 \pm 23.1 \text{ lbf} \cdot \text{ft}$ )
  - Normal clearance :  $0.5 \sim 1.0 \text{ mm}$   
( $0.02 \sim 0.04 \text{ in}$ )

- ※ If the bucket is not adjusted correctly, noise and vibration created during operation, and damaged O-ring, pin and bushing quickly.

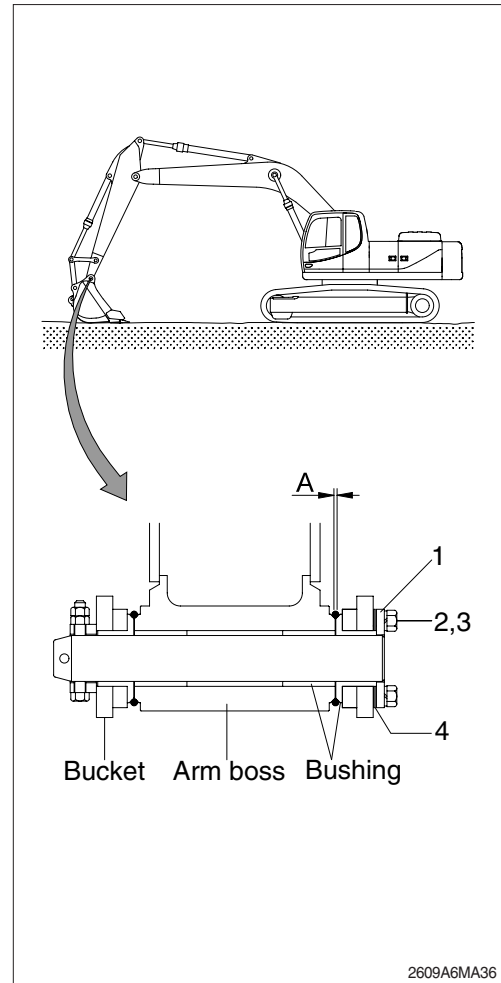

### 39) LUBRICATE PIN AND BUSHING

#### (1) Lubricate to each pin of working device

Lubricate the grease to the grease nipple according to the lubricating interval.

No.	Description	Qty
1	Lubrication manifold at boom	5
2	Boom cylinder pin	2
3	Boom and arm connection pin	1
4	Arm cylinder pin (rod side)	1
5	Bucket cylinder pin (head, rod)	2
	Bucket link (control rod)	3
	Arm and control link connection pin	1
	Arm and bucket connection pin	1
6	Boom rear bearing center	1

※ Shorten lubricating interval when working in the water or dusty place.

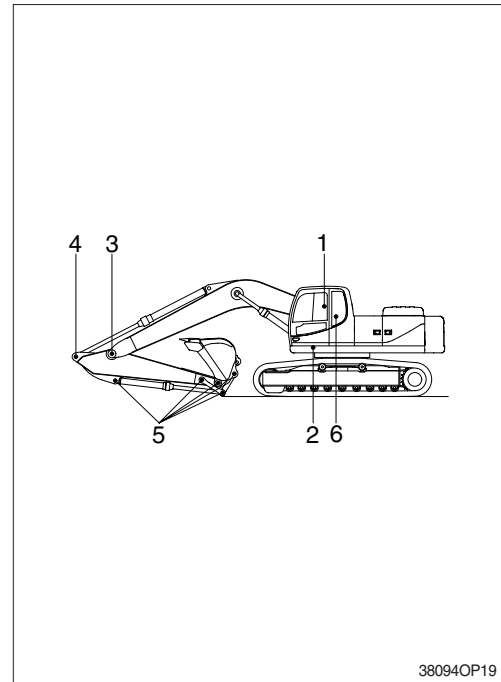

38094OP19

(2) Dust seals are mounted on the rotating part of working device to extend the lubricating interval.

※ Mount the lip to be faced outside when replace the dust seal.

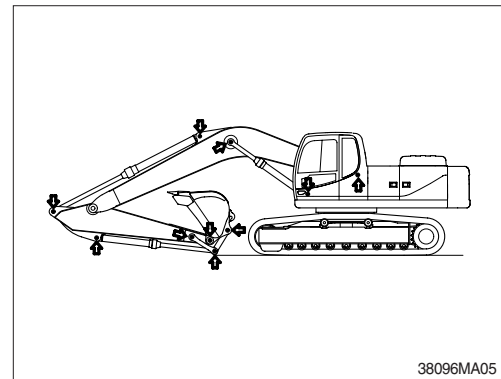

38096MA05

※ If it is assembled in wrong direction, it will cause fast wear of pin and bushing, and create noise and vibration during operation.

※ Assemble the seal same direction with picture and use with plastic hammer when replace.

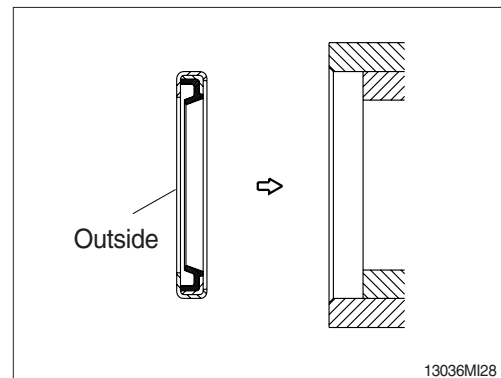

13036MI28

## 7. ELECTRICAL SYSTEM

### 1) WIRING, GAUGES

Check regularly and repair loose or malfunctioning gauges when found.

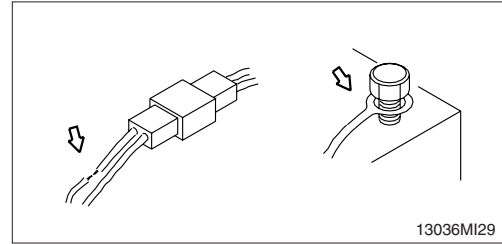

### 2) BATTERY

#### (1) Clean

① Wash the terminal with hot water if it is contaminated, and apply grease to the terminals after washing.

⚠ Battery gas can explode. Keep sparks and flames away from batteries.

⚠ Always wear protective glasses when working with batteries.

⚠ Do not stain clothes or skin with electrolyte as it is acid.

Be careful not to get the electrolyte in eyes.  
Wash with clean water and go to the doctor if it enters the eyes.

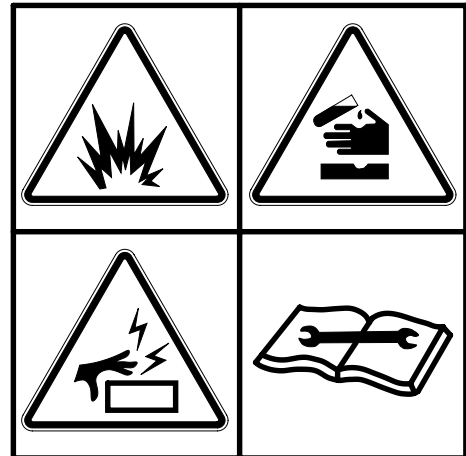

#### (2) Recycle

Never discard a battery.

Always return used batteries to one of the following locations.

- A battery supplier
- An authorized battery collection facility
- Recycling facility

#### (3) Method of removing the battery cable

Remove the cable from the ground connection first (⊖ terminal side) and reconnect it last when reassembling.

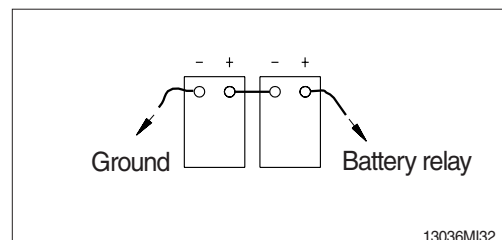

### 3) STARTING THE ENGINE WITH A BOOSTER CABLE

Keep following order when you are going to start engine using booster cable.

#### (1) Connection of booster cable

※ Use the same capacity of battery for starting.

- ① Make sure that the starting switches of the normal machine and trouble machine are both at the OFF position.
- ② Connect the red terminal of booster cable to the battery (+) terminal between exhausted and new battery.
- ③ Connect the black terminal of the booster cable between new battery (-) terminal and chassis of trouble machine.

※ Keep firmly all connection, the spark will be caused when connecting finally.

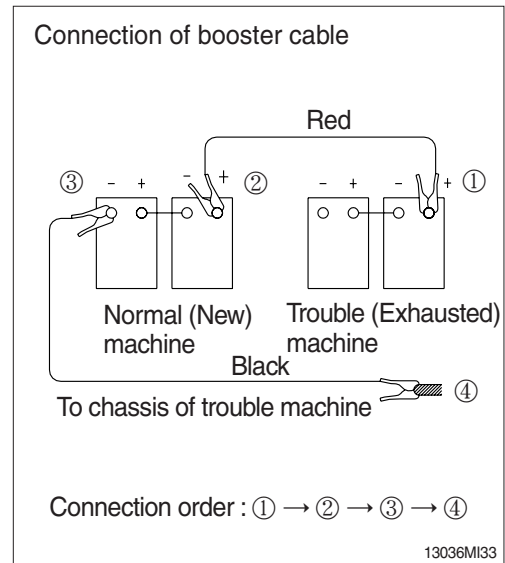

#### (2) Starting the engine

- ① Starting the engine of the normal machine and keep it to run at high idle.
- ② Start engine of the trouble machine with starting switch.
- ③ If you can not start it by one time, restart the engine after 2 minutes.

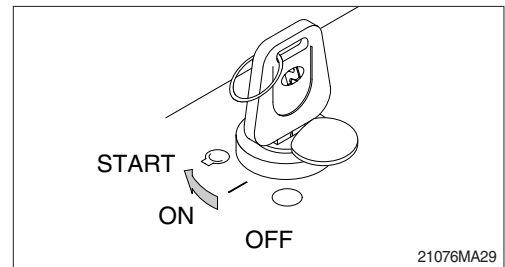

#### (3) Taking off the booster cable

- ① Take off the booster cable (black).
- ② Take off the booster cable (red) connected to the (+) terminal.
- ③ Run engine with high idle until charging the exhausted battery by alternator, fully.

▲ Explosive gas is generated while using the battery or charging it. Keep away flame and be careful not to cause the spark.

※ Charge the battery in the well ventilated place.

※ Place the machine on the earth or concrete. Avoid charging the machine on the steel plate.

※ Do not connect (+) terminal and (-) terminal when connecting booster cable because it will be shorted.

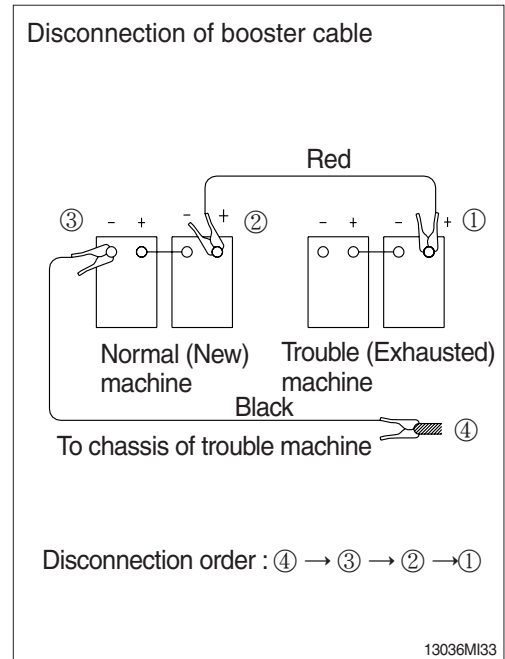

#### (4) Welding repair

Before start to welding, follow the below procedure.

- ① Shut off the engine and remove the starting switch.
- ② Disconnect ground cable from battery by master switch.
- ③ Before carrying out any electric welding on the machine, the battery cables should be disconnected and the connectors pulled out of the electronic control units (MCU, cluster etc).
- ④ Connect the earth (ground) lead of the welding equipment as close to the welding point as possible.

※ Do not weld or flame cut on pipes or tubes that contain flammable fluids. Clean them thoroughly with nonflammable solvent before welding or flame cutting on them.

▲ Do not attempt to welding work before carry out the above.

If not, it will caused serious damage at electric system.

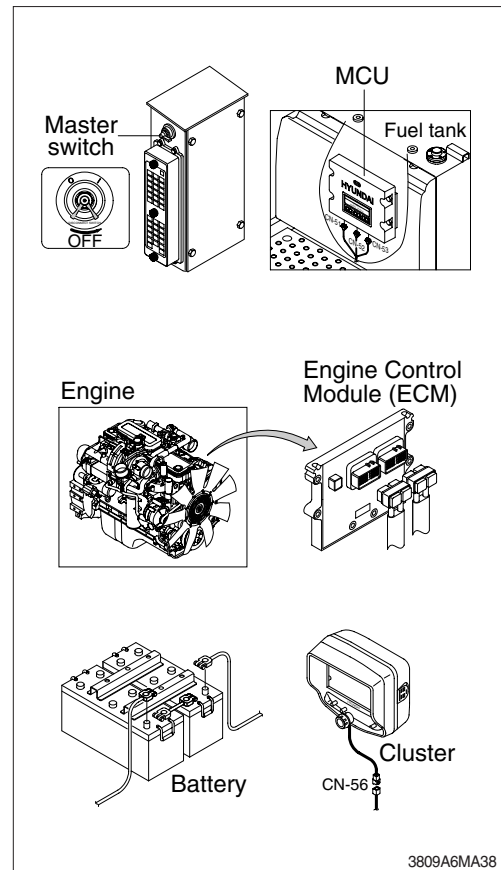

3809A6MA38

## 8. AIR CONDITIONER AND HEATER

### 1) CLEAN AND REPLACE OF FRESH AIR FILTER

※ Always stop the engine before servicing.

(1) Open the LH side cover.

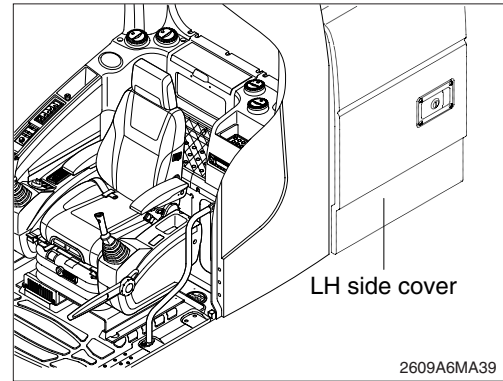

(2) Remove the fresh air filter.

※ When installing a filter, be careful not to change the filter direction.

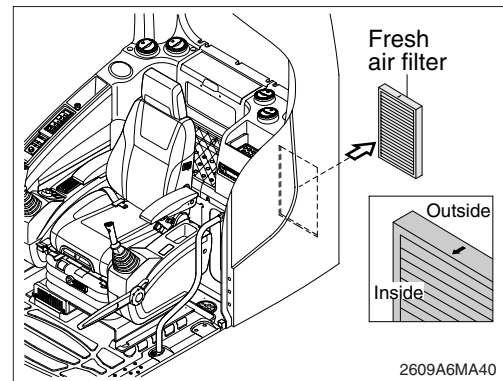

(3) Clean the filter using a pressurized air (below 2 kgf/cm<sup>2</sup>, 28 psi).

△ When using pressurized air, be sure to wear safety glasses.

(4) Inspect the filter after cleaning. If it is damaged or badly contaminated, use a new filter.

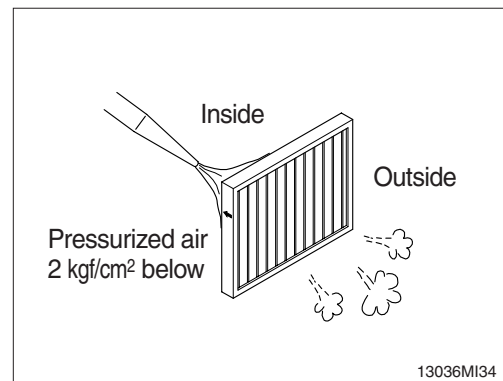

### 2) CLEAN AND REPLACE OF RECIRCULATION FILTER

※ Always stop the engine before servicing.

(1) Move seat and console box to arrow direction using the adjust knob.

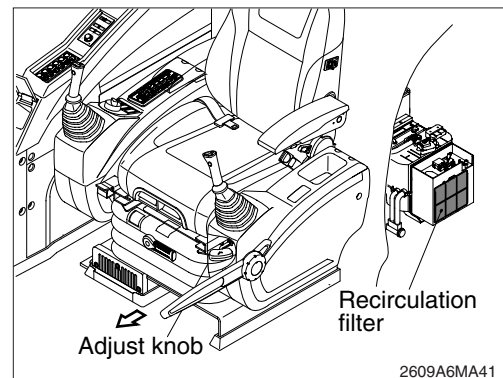



(2) Remove recirculation filter.

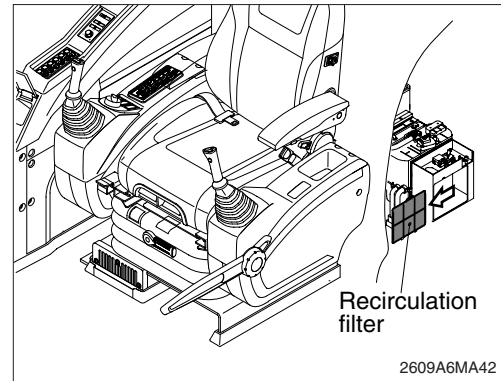

(3) Clean the recirculation filter using a pressurized air (below 2 kgf/cm<sup>2</sup>, 28 psi) or washing with water.

△ When using pressurized air, be sure to wear safety glasses.

※ Dry off after washing with water.

(4) Inspect the filter after cleaning. If it is damaged or badly contaminated, use a new filter.

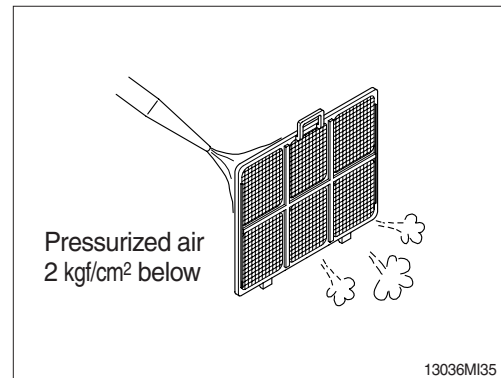

### 3) PRECAUTIONS FOR USING AIR CONDITIONER

- (1) When using the air conditioner for a long time, open the window once every one hour.
- (2) Be careful not to overcool the cab.
- (3) The cab is properly cooled if the operator feels cool when entering there from outside (about 5°C lower than the outside temperature).
- (4) When cooling, change air occasionally.

### 4) CHECK DURING SEASON

Ask the service center for replenishment of refrigerant or other maintenance service so that the cooling performance is not damaged.

### 5) CHECK DURING OFF-SEASON

Operate the air conditioner 2 or 3 times a month (each for a few minutes) to avoid loss of oil film in the compressor.

6) Refrigerant (R134-a) amount : 800 ± 20 g

# TROUBLESHOOTING GUIDE

## 1. ENGINE

※ This guide is not intended to cover every conditions, however many of the more common possibilities are listed.

Trouble	Service	Remark
The engine oil pressure lamp lights ON when engine speed is raised after completion of warm up.	<ul style="list-style-type: none"> <li>· Add the oil to the specified level.</li> <li>· Replace the oil filter cartridge.</li> <li>· Check oil leakage from the pipe or the joint.</li> <li>· Replace the monitor.</li> </ul>	
Steam is emitted from the top part of the radiator (the pressure valve). Coolant level warning lamp lights ON.	<ul style="list-style-type: none"> <li>· Supply the coolant and check leakage.</li> <li>· Adjust fan belt tension.</li> <li>· Wash out inside of cooling system.</li> <li>· Clean or repair the radiator fin.</li> <li>· Check the thermostat.</li> <li>· Tighten the radiator cap firmly or replace the packing of it.</li> <li>· Replace the monitor.</li> </ul>	
The engine does not start when the starting motor is turned over.	<ul style="list-style-type: none"> <li>· Add fuel.</li> <li>· Repair where air is leaking into fuel system.</li> <li>· Check the injection pump or the nozzle.</li> <li>· Check the valve clearance.</li> <li>· Check engine compression pressure.</li> <li>· In cold weather, check if fuel warmer system is working normal.</li> </ul>	Refer to the pages 3-27 and 4-4.
Exhaust gas is white or blue.	<ul style="list-style-type: none"> <li>· Adjust to specified oil quantity.</li> <li>· Replace with specified fuel.</li> </ul>	
Exhaust gas occasionally turns black.	<ul style="list-style-type: none"> <li>· Clean or replace the air cleaner element.</li> <li>· Check the nozzle.</li> <li>· Check engine compression pressure.</li> <li>· Clean or replace the turbocharger.</li> </ul>	
Combustion noise occasionally changes to breathing sound.	<ul style="list-style-type: none"> <li>· Check the nozzle.</li> </ul>	
Unusual combustion noise or mechanical noise.	<ul style="list-style-type: none"> <li>· Check with specified fuel.</li> <li>· Check over-heating.</li> <li>· Replace the muffler.</li> <li>· Adjust valve clearance.</li> </ul>	

## 2. ELECTRICAL SYSTEM

Trouble	Service	Remark
Lamp does not glow brightly even when engine runs at high speed. Lamp flickers while engine runs.	<ul style="list-style-type: none"> <li>· Check for loose terminals and open-circuit wiring.</li> <li>· Adjust belt tension.</li> </ul>	
Battery charging lamp does not go out even when engine runs at high speed.	<ul style="list-style-type: none"> <li>· Check the alternator.</li> <li>· Check and repair wiring.</li> </ul>	
Unusual noise is emitted from the alternator.	<ul style="list-style-type: none"> <li>· Check the alternator.</li> </ul>	
Starting motor does not turn when starting switch is turned ON.	<ul style="list-style-type: none"> <li>· Check and repair the wiring.</li> <li>· Charge the battery.</li> <li>· Check the starting motor.</li> <li>· Check the safety relay.</li> </ul>	
The pinion of the starting motor keeps going in and out.	<ul style="list-style-type: none"> <li>· Charge the battery.</li> <li>· Check the safety relay.</li> </ul>	
Starting motor turns the engine sluggishly.	<ul style="list-style-type: none"> <li>· Charge the battery.</li> <li>· Check the starting motor.</li> </ul>	
The starting motor disengages before the engine starts up.	<ul style="list-style-type: none"> <li>· Check and repair the wiring.</li> <li>· Charge the battery.</li> </ul>	
The engine warming up lamp does not go ON.	<ul style="list-style-type: none"> <li>· Check and repair wiring.</li> <li>· Check the monitor.</li> </ul>	
The engine oil pressure lamp does not light up when engine is stationary (when the starting switch is in ON position.)	<ul style="list-style-type: none"> <li>· Check the monitor.</li> <li>· Check the caution lamp switch.</li> </ul>	
Battery charging lamp does not light up when the engine is stationary. (when the starting switch is in ON position.)	<ul style="list-style-type: none"> <li>· Check the monitor.</li> <li>· Check and repair the wiring.</li> </ul>	

### 3. OTHERS

Trouble	Service	Remark
Track slip out of place. Excessive wear of the sprocket.	· Adjust tension of track.	
Bucket either rises slowly or not at all.	· Add oil to specified level.	
Slow speed of travel, swing, boom, arm and bucket.	· Add oil to specified level.	
Unusual noise emitted from pump.	· Clean the hydraulic tank strainer.	
Excessive oil temperature rise of hydraulic oil.	· Clean the oil cooler. · Adjust fan belt tension. · Add oil to specified level.	

# HYDRAULIC BREAKER AND QUICK CLAMP

## 1. SELECTING HYDRAULIC BREAKER

- 1) Become familiar with the manual and select breakers suitable to machine specifications.
- 2) Make careful selection in consideration of oil quantity, pressure and striking force, to enable satisfied performance.
- 3) When apply a breaker to the machine, consult your local dealer of Hyundai for further explanation.

## 2. CIRCUIT CONFIGURATION

- 1) As for breaker oil pressure line, use extra spool of main control valve.
- 2) Set proper breaker pressure on load relief valve.
  - ※ The initial setting pressure of load relief valve for breaker is 210 bar.
- 3) The pressure of the ROBEX430LC-9A system is 330 kgf/cm<sup>2</sup> (4700 psi).

### 4) Adjusting oil quantity

- (1) Use the breaker mode from work tool of cluster.  
Use select switch to control the oil flow quantity.
  - Setting oil quantity (245 lpm)

#### Flow set

- Max flow : Set the maximum flow for the attachment.
- Flow level : Reduce the operating flow from maximum flow.
  - Breaker : Max 7 steps, reduced 10 lpm each step.

- (2) If the quantity of hydraulic oil is not controlled properly, it causes short lifecycle of the breaker and the machine by increased breaking force and count.

- 5) The accumulator should be used to the breaker charging and return line.  
If the accumulator is not used, it will be damage as the input wave is delivered.
  - ※ **Keep the pressure pulsation of pump below 60 kgf/cm<sup>2</sup> (853 psi) by installing the accumulator.**
- 6) Do not connect the breaker return line to the main control valve, but connect to the return line front of the cooler.
- 7) Do not connect the breaker return line to drain lines, such as of swing motor, travel motor or pump, otherwise they should be damaged.
- 8) One of spool of the main control valve should be connected to the tank.
- 9) Select the size of pipe laying considering the back pressure.
- 10) Shimless tube should be used for the piping. The hose and seal should be used Hyundai genuine parts.
- 11) Weld the bracket for pipe clamp to prevent damage caused by vibration.

Oil quantity setting

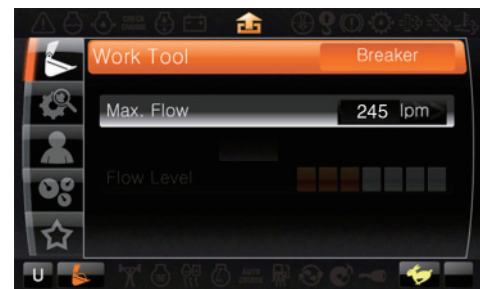

3809A8HB01

### 3. MAINTENANCE

#### 1) MAINTENANCE OF HYDRAULIC OIL AND FILTER

- (1) As machine with an hydraulic breaker provides the hydraulic oil becomes severely contaminated.
- (2) So, unless frequently maintained, the machine may easily go out of order.
- (3) Inspect and maintain hydraulic oil and 3 kinds of filter elements in particular, in order to prolong machine life.

#### 2) RELEASE THE PRESSURE IN BREAKER CIRCUIT

When breaker operating is finished, stop engine and push pedal or switch for breaker to release pressure in breaker circuit.

If pressure still remains, the lifetime of the diaphragm in the accumulator will be shortened.

- 3) Be careful to prevent contamination by dust, sand and etc.  
If such pollution become mixed into the oil, the pump moving parts will wear abnormally, shorten lifetime and become damaged.
- 4) When operating breaker, bolts and nuts of main equipment may be loosened by vibration. So, it must be inspected periodically.

Service interval unit : hours

Attachment	Operating rate	Hydraulic oil	Filter element
Breaker	100 %	600* <sup>1</sup>	200
		1000* <sup>2</sup>	

\*<sup>1</sup>: Conventional hydraulic oil

\*<sup>2</sup>: Hyundai genuine long life hydraulic oil

• **Replace following filter same time**

- Hydraulic return filter : 1 EA
- Pilot line filter : 1 EA
- Drain filter cartridge : 1 EA

Hyd oil change guide for hydraulic breaker

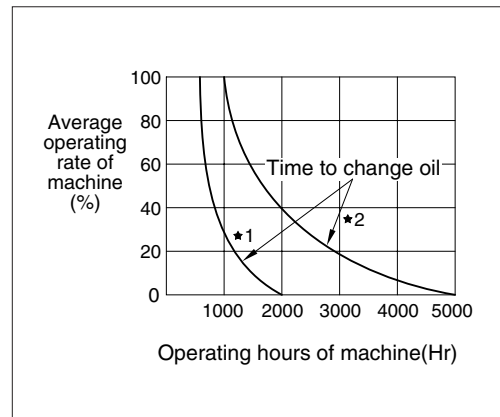

\*<sup>1</sup>: Conventional hydraulic oil

\*<sup>2</sup>: Hyundai genuine long life hydraulic oil

## 4. PRECAUTIONS WHILE OPERATING THE BREAKER

### 1) DO NOT BREAK ROCK WHILE LOWERING

As the breaker is heavy in comparison with bucket, it must be operated slowly.

If breaker is rapidly pushed down, working device may be damaged.

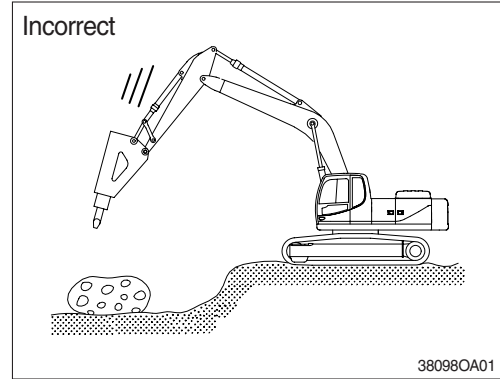

### 2) DO NOT USE BREAKER TO CARRY BROKEN STONE OR ROCK BY SWING OPERATING

This may damage the operation device and swing system.

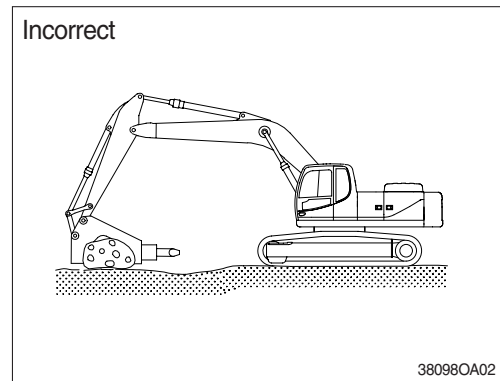

### 3) OPERATE BREAKER WITH A GAP IN EXCESS OF 100 mm (4 inches) FROM THE END OF THE STROKE TIP

If breaker is operated with the end tip, the cylinder may be damaged.

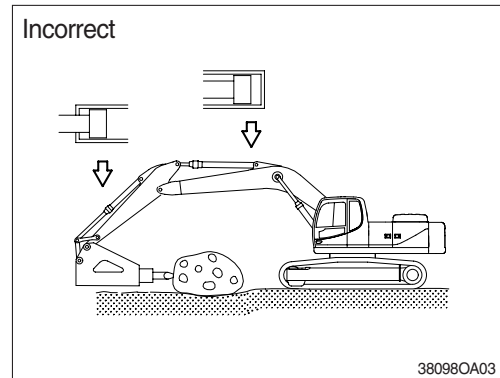

### 4) IF THE HYDRAULIC HOSES VIBRATE EXCESSIVELY

If the machine used in this condition continuously this will effect badly on the machine such as loosening bolt, oil leakage, damage of pump pipe and etc.

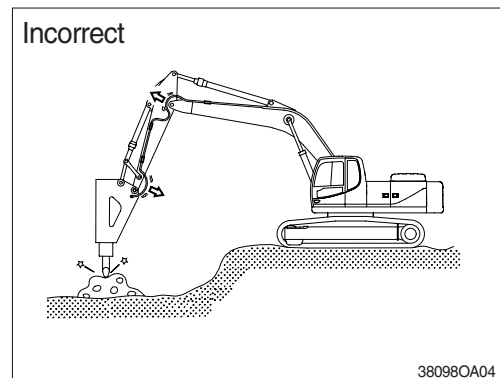



**5) DO NOT CONTINUE TO WORKING OVER ONE MINUTE AT SAME POSITION OF BOOM AND ARM**

This will increase the temperature of the oil, and cause problem in the accumulator and seals.

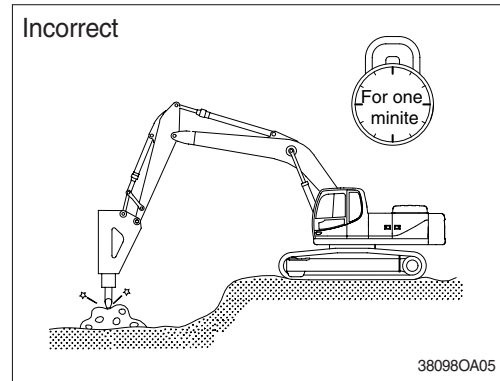

**6) DO NOT MOVE MACHINE OR BREAKER WHILE STRIKING**

Do not move hammer while striking.  
This will cause damage to the working device and the swing system.

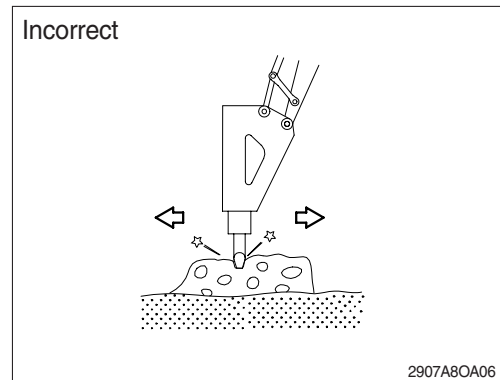

**7) DO NOT WORK WHILE SWING STATE**

Do not work while swing position of superstructure.  
It cause the band of track shoe, oil leakage of roller.

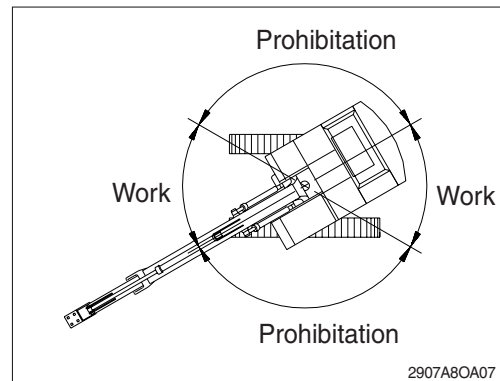

**8) TAKE CARE OF CHISEL AND BOOM INTERFACE**

Make sure of the arm and bucket control lever operation.

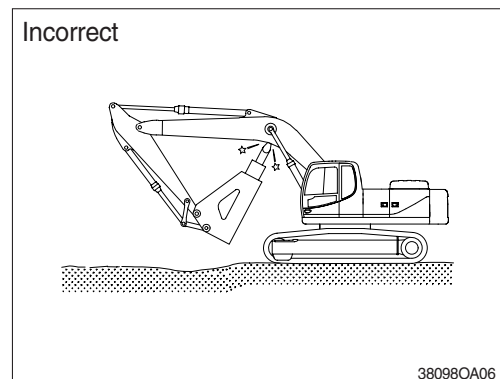

## 5. QUICK CLAMP

### 1) FIXING BUCKET WITH QUICK CLAMP

- (1) Before fixing bucket, remove safety pin of the moving hook.
- (2) Pulling safety button, press the quick clamp switch to unlock position. Then, the moving hook is placed on release position.

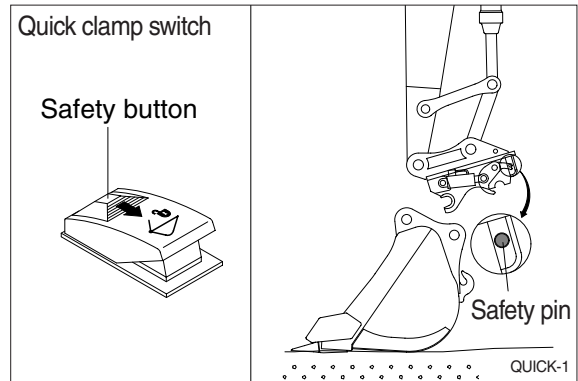

- (3) Aligning the arm and bucket, insert static hook of quick clamp to the bucket pin.

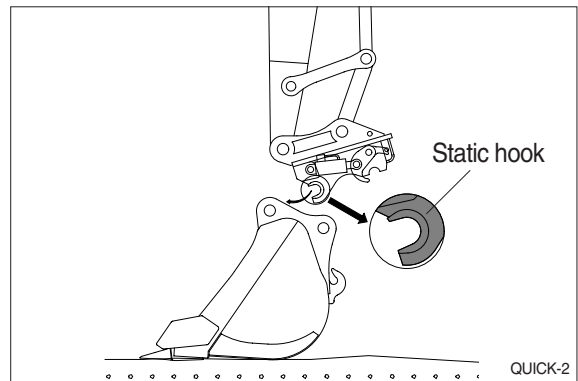

- (4) Operate RCV lever to bucket-in position. Then, the moving hook is coupled with the bucket link pin. Make sure that the moving hook is completely contacted with bucket link pin.

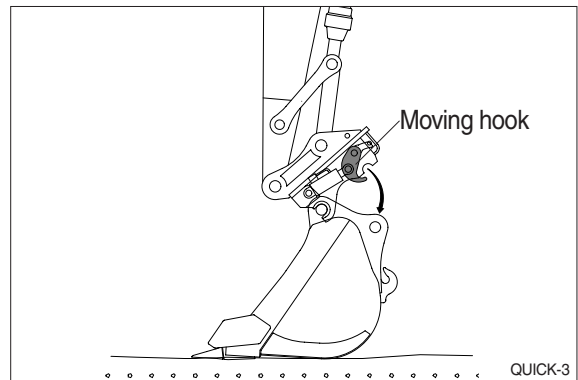

- (5) Push safety button to lock position. Operate RCV lever to bucket-in position.  
※ **Be sure to check connection status between bucket pins and hooks of quick clamp.**

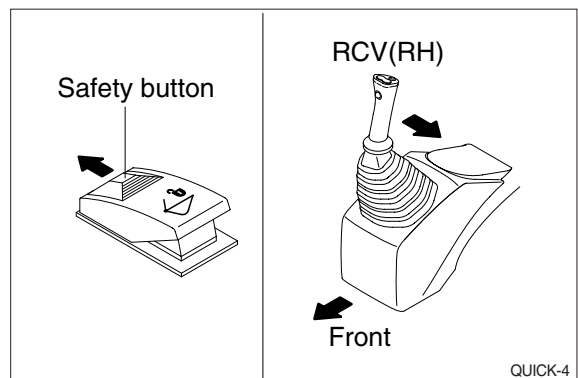

- (6) After checking the connection status between bucket pins and hooks of quick clamp, insert safety pin of moving hook to lock position.

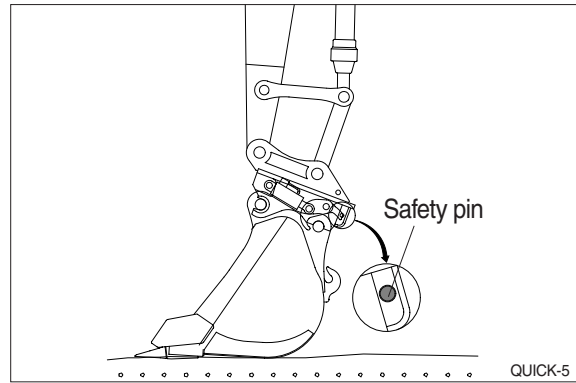

**2) REMOVE BUCKET FROM QUICK CLAMP**

Removing procedure is reverse of fixing.

**3) PRECAUTION OF USING QUICK CLAMP**

- ⚠ When operating the machine with quick clamp, confirm that the quick clamp switch is lock position and safety pin of moving hook is inserted.

Operating the machine with quick clamp switch unlocked and without safety pin of moving hook can cause the bucket to drop off and bring about the accident.

- ⚠ Serious injury or death can result from this accident.

- ⚠ Be careful to operate the machine equipped with quick clamp. The bucket may hit cab, boom and boom cylinders when it reaches vicinity of them.

HYUNDAI will not be responsible for any injury or damage in case that safety pin is not installed properly.

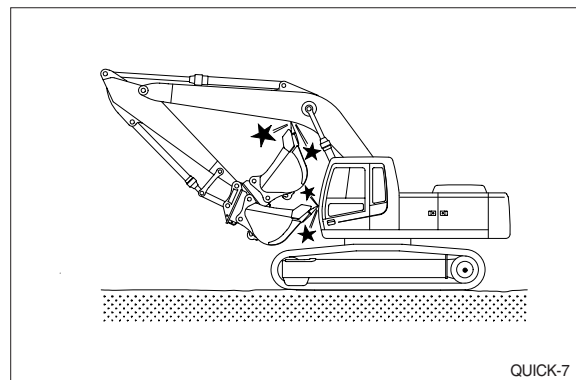
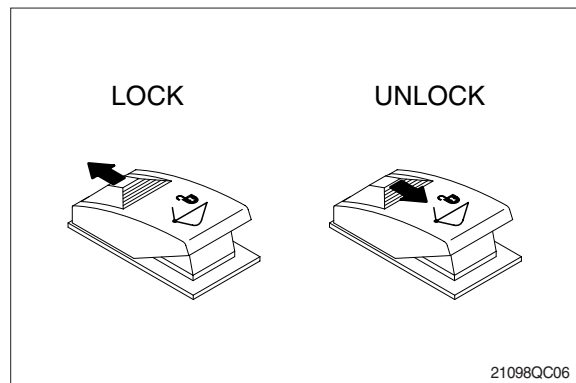

## 1. SEMI AUTO GREASE LUBRICATION SYSTEM

### 1) MAJOR COMPONENT

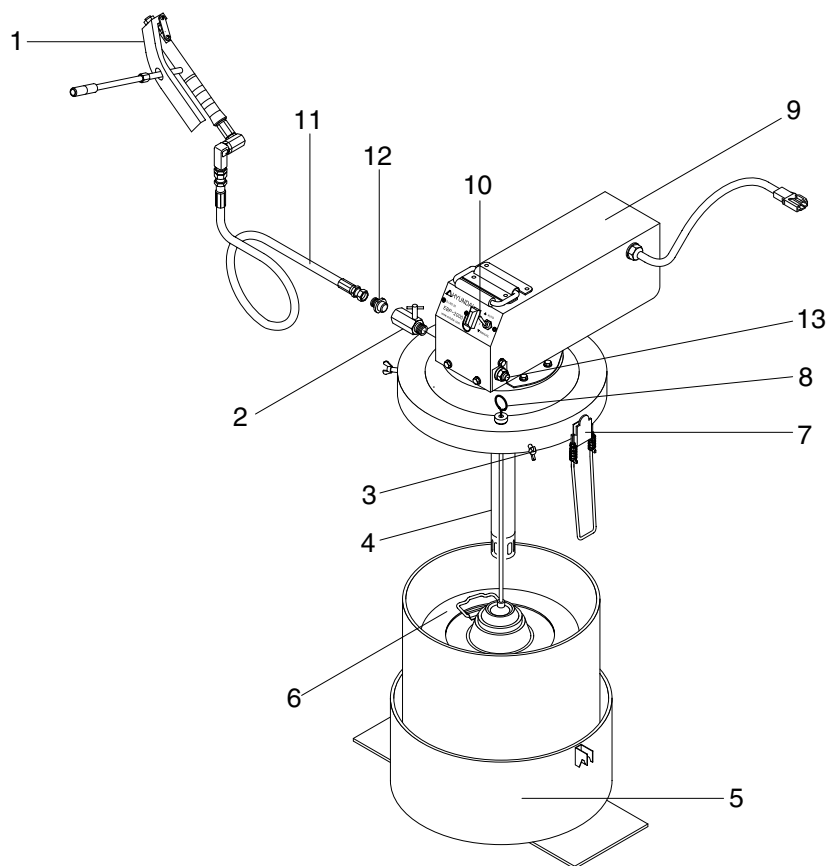

380LC8AG01

- |                          |                                |
|--------------------------|--------------------------------|
| 1 Grease gun             | 8 Level gauge                  |
| 2 Inline check & airvent | 9 Grease pump                  |
| 3 Wing bolt              | 10 Grease lubrication switch   |
| 4 Piston & cylinder      | 11 Grease hose                 |
| 5 Grease can holder      | 12 Grease filter               |
| 6 Follower plate         | 13 Over pressure control valve |
| 7 Grease can clamp       |                                |

### • Specifications

Item	Specification
Input power	24VDC
RPM	60
Current	15 amp
Output volume	110.0 cc/min $\pm$ 20%
Pressure	Max. 280 bar $\pm$ 20%
Operating temperature	-35°C to 70°C (depending on the grease type)
Weight	15 kg
Filter	1st filter ; 1.0 mm, 2nd filter ; 0.2 mm
Grease can	20 liter
Grease hose	10 meter

## 2) PREPARATION FOR OPERATION

### (1) Instruction

- ※ Place the unit on flat and stable place.
- ※ After you use the grease, please make sure to change it into new grease can. Never use it by filling the grease, for it becomes the cause of system failure.

- ① Loosen the wing bolts, clamp and remove the grease pump from the grease can.
- ② Remove the follower plate and level gauge.
- ③ Change a new grease can.
- ④ Place the follower plate on the grease can horizontally and push it down by rubbing it to left and right with hand until the grease comes out from the packing in the middle of the follower plate.

- ※ Take care not to allow sand and dust to adhere on the suction tube and follower plate of the pump.

- ⑤ Place the magnetic of level gauge on the follower plate.
- ⑥ Insert the grease pump into the center of grease follower plate.
- ⑦ Install the clamp tight (2EA) according the height of can and tighten the wing bolt (3EA).
- ⑧ Check the power connector.

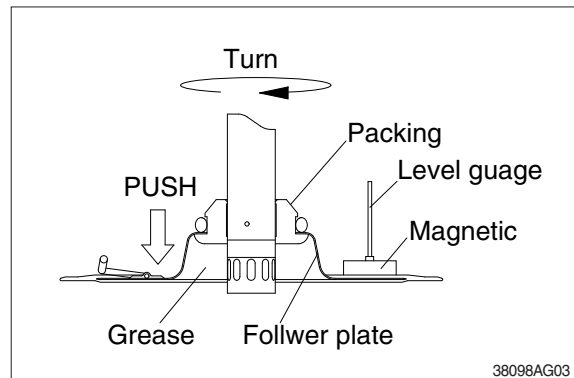
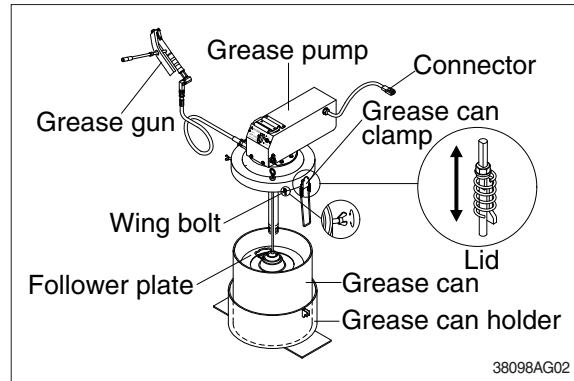

## (2) Grease gun operation

- ① Switch on to the MANUAL.
- ② Open the inline check & airvent valve and operate the pump until grease will be discharged from a small hole under check valve.
- ③ After grease is discharged fully, close the valve handle.

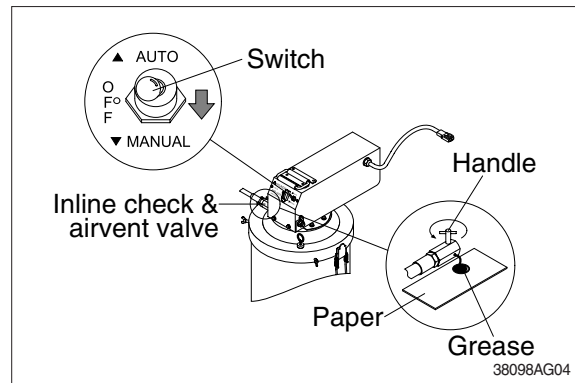

- ④ Switch on to the AUTO, take out grease gun and hose to the point where you want to lubricate and lubricate a grease to lube point after hold grease gun handle.
- ⑤ Rearrange the grease gun and hose after lubricate all lube points and keep it in the tool box.
- ⑥ Switch OFF.

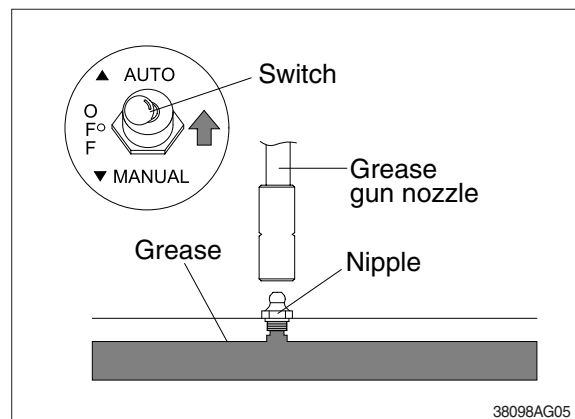

- ※ It could be reducing a grease output volume after 30 minute running.
- ※ When you use pump lower than  $-10^{\circ}\text{C}$  continuously, you should use a low temperature grease.
- ※ The grease mixed air is cloudy in white replace the new grease.

## (3) Grease level check

- ① Hold the level gauge handle and make straight line between the gauge plate attached follower plate and gauge handle.
  - ② Check the length of the level gauge between gauge handle to the top of pump. The distance of gauge (wire rope) is indicated grease level.
  - ③ When grease level goes down to the empty the level gauge plate will be separated from the follower plate (It is attached with magnet). Replace the new grease can.
- ※ Pump will be pumping out a remaining grease for 3 minutes after the grease level indicated empty.

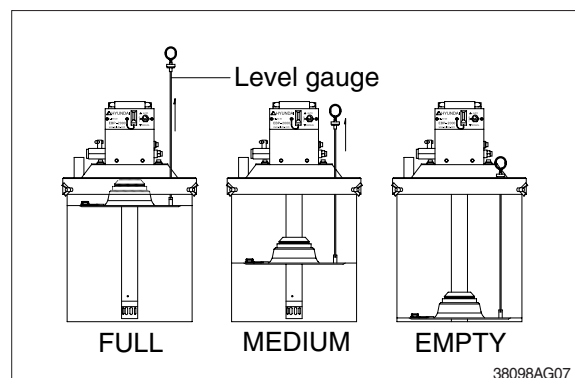

### 3) SAFETY INSTRUCTION AND MAINTENANCE

#### (1) Safety instruction

- ① Do not use silicon grease.
- ② Do not operate the grease gun with the discharge port facing to another person during machine operation at any case.
- ③ After the end of using pump, please be sure to shut off the power of this machine to release the internal pressure.
- ④ When replacing any port as maintenance, please be sure to stop the power to the machine.

#### (2) Maintenance

- ① If any leakage is found, replace seals leaked and also it is required to replace them once a year.
- ② Check whether pump could pump the accurate grease volume or not periodically.
- ③ Please clean grease filter if output volume is less then 25% of stroke volume. (110 cc/min)

### 4) TROUBLESHOOTING

Category	Applications	Service
Pump does not work	Electric cable is broken Pump is defective	Renew the electric cable and fuse Replace the pump
Pump is working but does not supply of lubrication	Grease low level Air packed in the grease can Air packed in the lube line Defective pump element Defective cam and piston Pipes are burst or leakage Defective over pressure valve	Replace the grease can Remove air packet using with follower plate Remove air packet using inline air vent handle Replace the pump element Replace the pump piston Renew the pipes Replace the over pressure valve
Could not either pump high pressure or accurate grease volume	Defective over pressure valve Defective seal in side pump Defective pump parts	Replace the over pressure valve Replace the pump seal Replace the pump parts
Reduced pump speed	Pump and grease pipes is blocked Low ambient temperature	Check and replace the grease pipes Replace the low temperature grease
Leakage of grease at the over pressure valve	Grease filter is blocked Grease pipes is blocked	Clean grease filter Clean grease pipes

<b>A</b>	
Accel dial switch .....	3-28
After engine start .....	4-5
Air breather element .....	6-37
Air cleaner filter .....	6-29
Air conditioner & heater .....	3-34
Air conditioner filter .....	6-48
Alternate exit .....	0-11
Attachment lowering .....	4-23
<b>B</b>	
Battery .....	6-45
Before starting engine .....	4-2
Boom lowering .....	4-23
Bucket clearance adjustment .....	6-43
Bucket replacement .....	6-41
Bucket selection guide .....	2-6
Bucket tooth replacement .....	6-42
<b>C</b>	
Cab air filter .....	6-48
Cab device .....	3-1
Changing machine control pattern .....	4-26
Cigar lighter .....	3-38
Cluster .....	3-2
Coolant .....	6-21
Cooling fan .....	6-26
Crankcase breather filter .....	6-33
<b>D</b>	
DMB .....	3-26
DPF (diesel particulate filter) .....	6-33
Drain filter .....	6-37
<b>E</b>	
Emergency engine speed connector .....	3-60
Engine oil filter .....	6-18
Engine oil level .....	6-18
Engine starting & stop .....	4-3
Engine starting by booster .....	6-46
Engine stop .....	4-6
<b>F</b>	
Fan belt .....	6-26
FMT .....	3-26
Fuel filter .....	6-30
Fuel leakage .....	6-31
Fuel system bleeding .....	6-31
Fuel tank .....	6-30
Fuse & relay box .....	3-59
<b>G</b>	
Gauge .....	3-3
<b>H</b>	
Handsfree .....	3-39
HEST .....	3-7
Hydraulic breaker .....	8-1
Hydraulic oil changing .....	6-35-1
Hydraulic oil filling .....	6-35
Hydraulic oil level .....	6-35
<b>L</b>	
LCD .....	3-2
Levers & pedals .....	3-32
Lifting capacities .....	2-5
Lubricant specification .....	2-12
<b>M</b>	
Maintenance check list .....	6-11
Major component .....	2-1
MCU (Machine Control Unit) .....	3-59
Mode selection system .....	4-7
Monitor panel .....	3-2
Mounting and dismounting .....	1-12
<b>N</b>	
New machine operation .....	4-1
<b>O</b>	
Oil cooler .....	6-25
Operating pattern .....	4-26
<b>P</b>	
Pedals .....	3-33
Periodical replacement parts .....	6-5
Pilot filter .....	6-37
Pin & bushing lubrication .....	6-44
Prefilter .....	6-32
Pilot lamps .....	3-9
<b>Q</b>	
Quick clamp .....	8-6
<b>R</b>	
Radiator flushing .....	6-22



Radio & USB player .....	3-45	Windshield .....	3-61
RCV lever lubricate .....	6-40	Working device operation .....	4-12
Recommended oils .....	2-12, 6-10	Working method .....	4-16
Regeneration system .....	4-29	Working range .....	2-3
Relieving pressure .....	6-3		
Remote controller .....	3-42		
Return filter .....	6-36		
RCV lever operating pattern .....	4-26		

## S

Safety hints .....	1-1
Safety labels .....	0-5
Safety parts .....	6-5
Seat .....	3-58
Seat belt .....	3-58
Service meter .....	3-60
Service socket .....	3-40, 3-60
Smart key tag .....	3-27
Specification for major component .....	2-9
Specification .....	2-2
Start switch .....	3-27
Storage .....	4-24
Suction strainer .....	6-36
Swing bearing grease .....	6-38
Swing gear & pinion grease .....	6-38
Swing reduction gear oil .....	6-38
Switch panel .....	3-27
Switches .....	3-12, 3-27

## T

Torques-major component .....	6-8
Torques-fastener .....	6-6
Towing machine .....	4-15
Track adjustment .....	6-40
Track shoe selection .....	2-7
Transportation .....	5-1
Travel reduction gear oil .....	6-39
Traveling machine .....	4-13
Troubleshooting guide .....	7-1

## U

Undercarriage .....	2-7
USB socket .....	3-39

## W

Warming up operation .....	4-5
Warning lamps .....	3-4
Weight .....	2-4